



2N Lift8

User Manual



Table of Contents

Product Description	7
Product Overview	7
System Diagrams	7
Components and Associated Products	8
2N Lift8 System Components	8
Cooperating 2N Applications	19
Associated 2N Products	20
Upgrade	22
Terms and Symbols	24
Description and Installation	26
Central Unit	26
Central Unit – Description	26
Central unit – Mechanical Installation	30
Central Unit – Electrical Installation	31
Central Unit – Bus Wiring	34
Central Unit – Network Connection	38
Splitter	40
Description	40
Electric Installation	41
Mounting Types Overview	43
Audio Unit – COP	44
Description	44
Before You Start	45
Mounting	46
Electric Installation	48
LED Indicator Connection	54
External Pictogram	56
Volume Settings	57
Induction Loop Connection	58
Rescue Process	58
Audio Unit – Machine Room	59
Description	59
Before You Start	60
Mounting	60
Electronic Installation	60
Volume Settings	62
Audio Unit – Machine Room, PCB	63
Audio Unit – Shaft	67
Description	67
Before You Start	68
Mounting	68
Electronic Installation	68
Volume Settings	70
Audio Unit – Compact	70
Description	70
Before You Start	71
Mounting	71
Electric Installation	72
Connectors	74
Rotary Switch	74
ALARM and CANCEL Settings (Rotary Switch)	75
Volume Settings	76
Mounting Completion	77
PSTN Module	79

LTE/UMTS/GSM Module	81
Audio Unit – Fireman	84
Fireman PCB	84
Fireman	90
Fireman – Mechanical Mounting	95
MEEF Evacuation Audio Unit – Cabin Connection	101
Mechanical Installation	103
Electric Installation	104
Volume Settings	106
Evacuation Audio Unit – Evacuation of Floors	107
Description	107
Mechanical Installation	107
Electric Installation	109
Procedure	110
Volume Settings	111
2N IP Phone D7A	111
Description	111
Wiring	112
I/O module	112
Description	112
Electronic Installation	113
Mounting Types Overview	117
RS232 Module	118
Description	118
Before You Start	119
Description of Connection	119
Supported AT Commands	121
Serial Port Configuration	122
System Configuration	123
2N Lift8 Programming	123
Before you start programming via a call	123
Access to Programming Mode	123
Troubleshooting	124
Troubleshooting	124
Programming via Service Tool	125
Programming Using Lift DTMF config	125
Use	125
Options	127
Lift config group	127
Overview of All Programming Functions	129
Service parameters	158
Configuration by PC	160
How to record a message	160
Configuration by SMS	160
Function Description	160
Set administrator password using PWD command	161
Basic Settings (CNF)	161
Factory Configuration Reset (DEF)	163
Central Unit restart (RST)	163
Profile change (SET)	163
Device Info (INF)	163
Error Responses	164
Function Description	165
Used Ports	165
Communication in Elevator Shafts	166
Basic Features	166

System diagram	167
User Instructions	168
Cabin	168
Shaft, Cabin Roof	168
Machine Room	169
Control Room Instructions	170
ALARM Call	170
Control Room-to-Elevator Calling	170
Tone Dialing Control during Call – Long Command List	172
Function Description (for Advanced Users)	173
Purpose of this section	173
Outgoing Call	173
Outgoing Machine Room Calls	173
TRIPHONY	175
Checking Call	175
Operational Call	176
Incoming Call	176
Call Queuing	177
Automatic Checking/Operational Call Answering	178
Call Confirmation Types	180
1. With DTMF Confirmation	180
2. Automatic Repeated Dialing of Multiple Numbers without Confirmation	181
3 and 4. CPC (Antenna and KONE)	181
5. P100	182
6. DTMF Protocol Auto Detection (CPC/P100)	182
7, 8, 9. CPC (Antenna a KONE), P100 2N ext	182
Elevator Blocking Function	182
Intercom Function	183
ALARM – Intercom Calls	183
Number Setting for Machine Room – Control Room Audio Unit Calls	184
System Completeness Check and Audio Unit Audio Test	185
Features	185
System Completeness Check Enable	185
Audio Unit Audio Test	186
Event after Audio Error	186
System Completeness Check Disable	187
Parameter 990	187
ALARM Button Test	187
Parameter 990	188
Rescue Process Activation / End	188
Rescue Process Activation	188
Rescue Process End	188
Event after Rescue End	188
Parameter 990	189
Battery Replacement	189
Parameter 990	190
CPC and P100 Protocols	190
CPC	190
P100	193
Evacuation Mode	195
Mode Activation	195
System diagram	196
IP Phone Connection	197
2N Lift8 Service Tool Settings	197
Audio Unit Name Setting	198
2N IP Phone D7A Settings	199

Directory Settings	199
Control Room Instructions	200
2N IP Phone – Control Room	200
Dialing Number	200
Dialing Number	200
Dialing Number 99 – Evacuation Report	201
Call Answering	201
End of Call	202
Redial – Dial the Last Called Number	202
User Instructions – Floor Audio Unit	202
Service Tool	203
Installation and Login	203
System Requirements and Preparation	203
Standard Installation (Wizard)	204
Installation via Command Line	205
Login	206
Introduction to Application	208
Use of Service Tool	214
Configuration	214
Logs	223
Bus Logs	226
Evacuation	228
User Messages	229
Devices	231
Surveillance	234
Service Tool for Android	237
Installation and Licensing	237
Google Play Installation	237
.apk Package Installation	239
Central Unit Connection	239
Use	240
Central Unit Login	240
Configuration	242
Parameter Editing	243
Firmware Upgrade	245
Maintenance	246
Operation Interruption and Battery Replacement	246
Operation Interruption and Battery Replacement	246
Firmware Upgrade (Update)	248
Procedure	248
Delete All User Data	248
Press RESET	249
Service Tool	249
DTMF Programming	249
Via SMS	249
Functionality Tests in Accordance with EN 81-28	249
6.2.2 ALARM Emergency Signaling Information (4.1.2)	250
6.2.3 ALARM Emergency Signaling End (4.1.3)	250
6.2.4 Emergency Power Supply (CU) (4.1.4) – Lift8	251
6.2.5 Visual and Acoustic Signals in Elevator Cage (4.1.5)	251
6.2.6 Communication (4.1.8), ALARM Emergency Signaling Verification (4.1.6), Identification (4.1.7)	253
Accessibility and Reliability (4.2.1)	253
Technical Parameters	254
Supplementary Information	257

Troubleshooting 257
 SIP Error Codes 257
List of Abbreviations 259
Regulations 260
General Instructions and Cautions 261
 Decommissioning and Environmental Disposal 261

Product Description

In this section, we introduce the **2N Lift8** product, outline its application options and highlight the advantages following from its use.

Product Overview

2N Lift8 (L8) is an advanced communication system for elevators. This system provides two modes of use:

- Elevator shaft communication in buildings – provides communication of the elevator shaft audio units with the control room. One Lift8 system (with one Central Unit) can serve up to 8 elevator shafts.
- Evacuation Mode – ensures reliable communication with the evacuation elevator floors, which is crucial for a safe and rapid evacuation of persons in emergency.

2N Lift8 meets the requirements of the TÜV and CE standards. 

System Diagrams

Example of the wiring diagram for the **2N Lift8** Central Unit, splitters and audio units in the Elevator shaft communication mode:

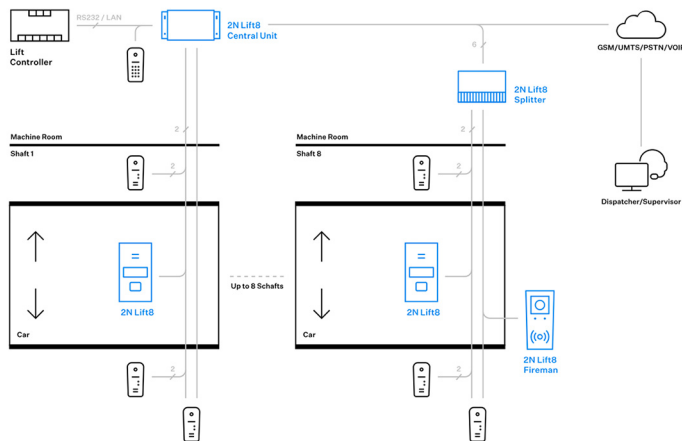

Wiring diagram of the **2N Lift8** system in the Evacuation mode:

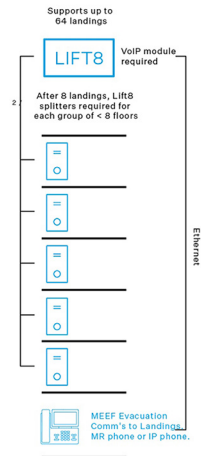

Components and Associated Products

2N Lift8 System Components



WARNING

- The components of the **2N Lift8** system cannot be used outside this system.
- The audio units cannot be connected to a telephone line without the CU!
- When shared by multiple shafts, the audio units cannot be connected without the CU and splitters.

918600 2N Lift8 – Central Unit

- Central unit
- Designed for the Elevator shaft communication and Evacuation modes
- For connection of up to 7 splitters. Including a power EURO cable and rechargeable battery. USB interface for configuration.
- This online documentation relates to multiple hardware versions, the availability of functions is different for each hardware version.



NOTE

The Central Unit in HW versions 2.x and lower fails to meet the conditions of the supplementary order to the EU Radio (Radio Equipment Directive) - effective from 1 August, 2025.

918620E 2N Lift8 – Splitter

- Splitter
- Designed for the Elevator shaft communication and Evacuation modes



Used for CU – audio unit interconnection.

918610E 2N Lift8 – Audio Unit COP

- Audio Unit – COP
- Designed for the Elevator shaft communication mode

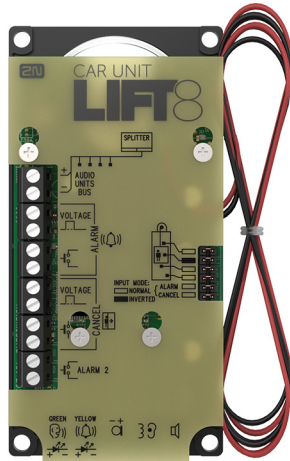

Audio unit electronics for elevator cabin building in. Including speaker and microphone (handsfree). Connection terminals for all prescribed elements and door opening signal input (optional).

918610XE 2N Lift8 – Audio Unit COP, Cable version

- Audio Unit – COP, Cable version
- Designed for the Elevator shaft communication mode

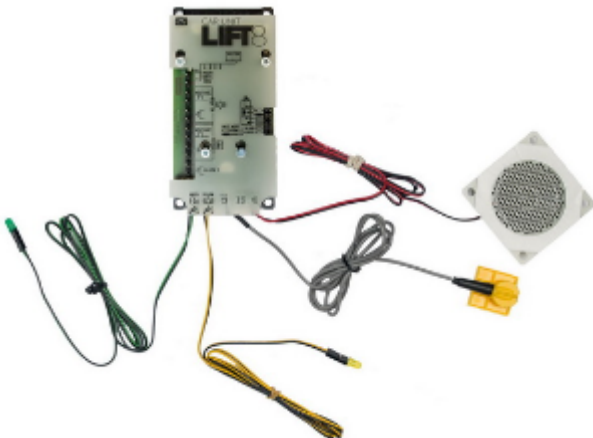

Audio unit electronics for elevator cabin building in. Contains LED, microphone and speaker connected via cables.

918611E 2N Lift8 – Audio Unit Machine Room

- Audio Unit – Machine Room/Control Room
- Designed for the Elevator shaft communication mode



Audio unit for the machine room/control room. Contains a handset (optional) and a keypad for easy control. Makes it possible to communicate with any other system audio units and configure the CU without a PC.

Equipped with an external siren connector. This audio unit can be shared by multiple elevators (shafts). Robust yellow cover.

918623E 2N Lift8 Audio Unit – Machine Room, PCB

- Designed for machine room installation for one elevator shaft or the Intercom solution.
- Designed for the Elevator shaft communication mode

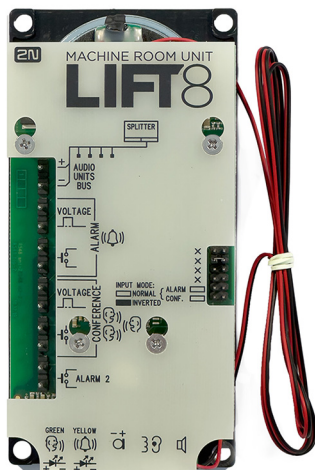

918612E 2N Lift8 – Audio Unit Shaft

- Audio Unit – Shaft
- Designed for the Elevator shaft communication mode



Audio unit for the cabin roof and shaft or cabin bottom. Robust yellow cover. Handsfree mode, ALARM button and Triphony, LED indicators. Not intended for use in the cabin.

918613E 2N Lift8 – Audio Unit Compact, With button

- Audio Unit – Compact, With button
- Designed for the Elevator shaft communication mode



Robust, heavy-duty design. Standard-sized ALARM button including signage for the blind and backlit pictograms (hardened glass).

Easy cabin wall mounting. Easy 2-wire connection.

918613WBE 2N Lift8 – Audio Unit Compact, Without button

- Audio Unit – Compact, Without button
- Designed for the Elevator shaft communication mode



Robust, heavy-duty design. Easy cabin wall mounting. Easy 2-wire connection.

918618BE 2N Lift8 – Audio Unit Flush, With button

- Audio Unit – Flush Mounting, With button
- Designed for the Elevator shaft communication mode



Audio unit electronics for installation in an elevator cabin with a 1.5 mm stainless steel cover in the anti-vandal version. The stainless steel cover includes the required pictograms and instructions for operating the alarm button.

918618E 2N Lift8 – Audio Unit Flush, Without button

- Audio Unit – Flush Mounting, Without button
- Designed for the Elevator shaft communication mode

Product Description

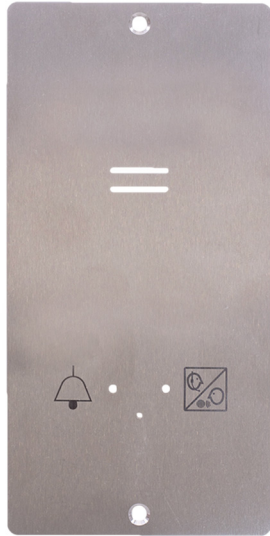

Audio unit electronics for installation in an elevator cabin with a 1.5 mm stainless steel cover in the anti-vandal version. The stainless steel cover includes the required pictograms.

918615E 2N Lift8 – Audio Unit Fireman (knob + 1 Push to Talk button)

- Audio – Unit Fireman (knob + 1 Push to Talk button)
- Designed for the Elevator shaft communication mode in fire elevators



Used for fire fighting operations. Activates the top priority call.

918619E 2N Lift8 – Audio Unit Fireman PCB (knob + 1 Push to Talk button)

- Audio Unit – Fireman PCB (knob + 1 Push to Talk button)
- Designed for the Elevator shaft communication mode in fire elevators

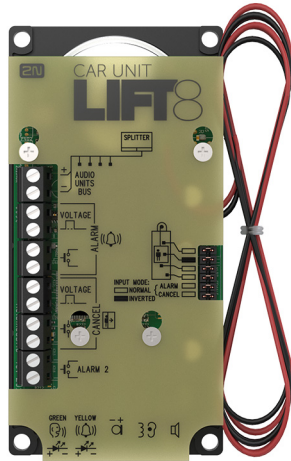

Used for fire fighting operations. Activates the top priority call.

918619E2 – 2N Lift8 Audio Unit MEEF (Evac.), for flush mounting

- Designed for the Elevator shaft communication mode

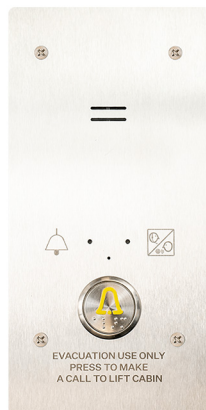

The evacuation audio unit for the MEEF (Main Elevator Evacuation Floor) is used for connection with the elevator cabin. Activates the top priority call.

918618EE – 2N Lift8 Audio Unit, Landing (Evac.), for flush mounting

- Evacuation audio unit – floors
- Designed for the Evacuation mode

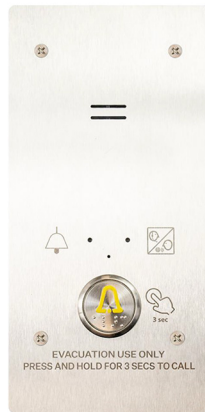

The Landing (Evac.) evacuation audio unit is used for making calls from the elevator floors to the central control room.

918621E 2N Lift8 – I/O Module

- Designed for the Elevator shaft communication mode



Contains logical inputs and switch relays.

918654E 2N Lift8 – RS232 Module

- RS232 module

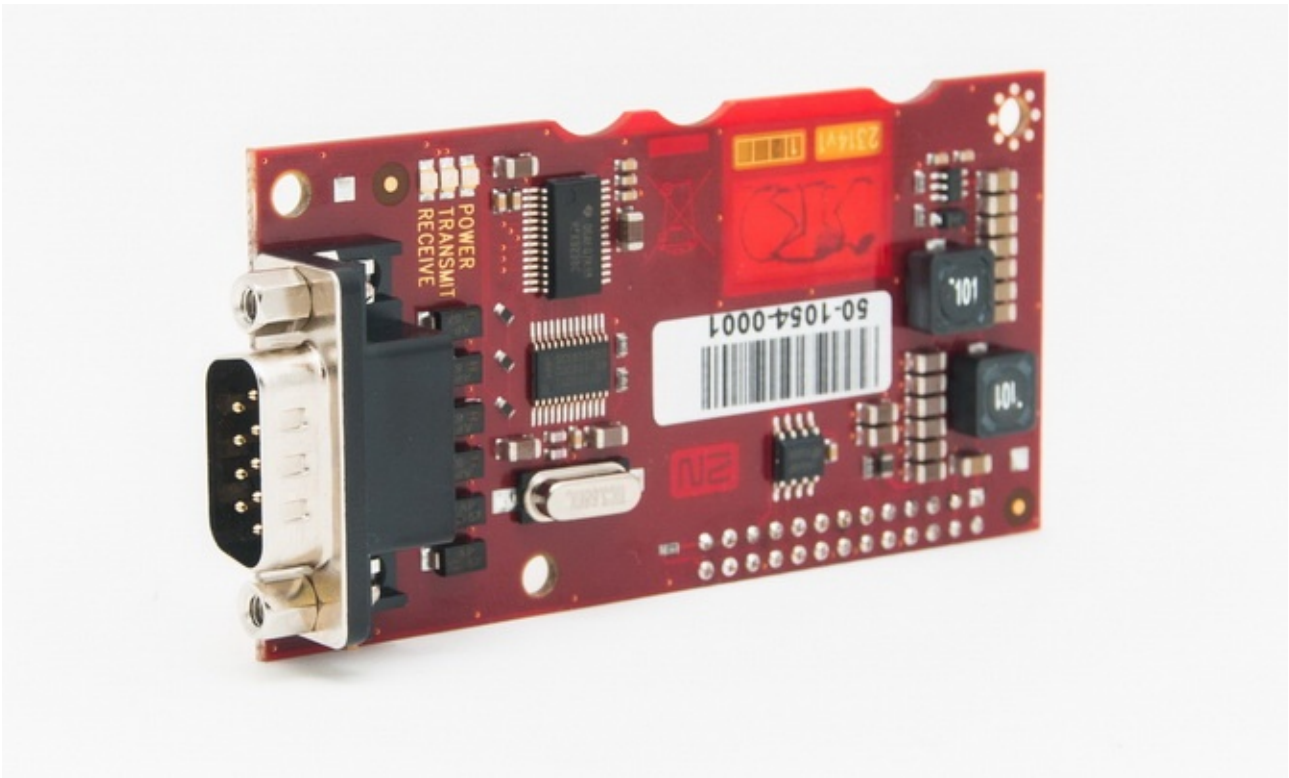

The RS232 module connects the 2N Lift8 system with the elevator control unit. The elevator control unit transmits a command via RS232 to the Central Unit for processing and executing.

918652E 2N Lift8 – PSTN Module

- PSTN module
- Designed for the Elevator shaft communication mode

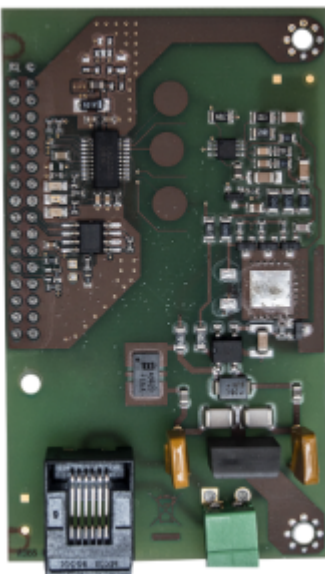

For the Central Unit connection via an analog line.

918658G 2N Lift8 – LTE Module Global

- LTE/UMTS/GSM module

- Designed for the Elevator shaft communication mode

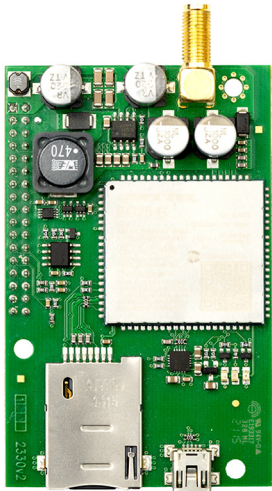

22041579 Antenna GSM/UMTS/LTE

- 9 dB
- cable length: 10 m
- SMA connector
- Designed for the Elevator shaft communication mode



Cooperating 2N Applications

918700E 2N Lift8 Service Tool

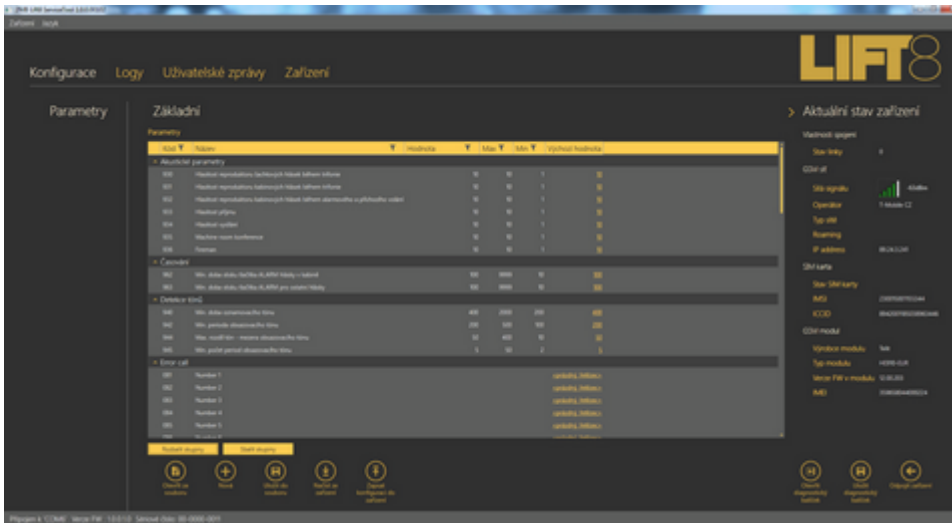

The 2N Lift8 Service Tool application is intended for remote supervision and configuration of the 2N Lift8 communicators.

918700E 2N Lift8 Control Panel

Designed for the Elevator shaft communication mode

The 2N Control Panel application is intended for administration of users, elevators and authorizations.

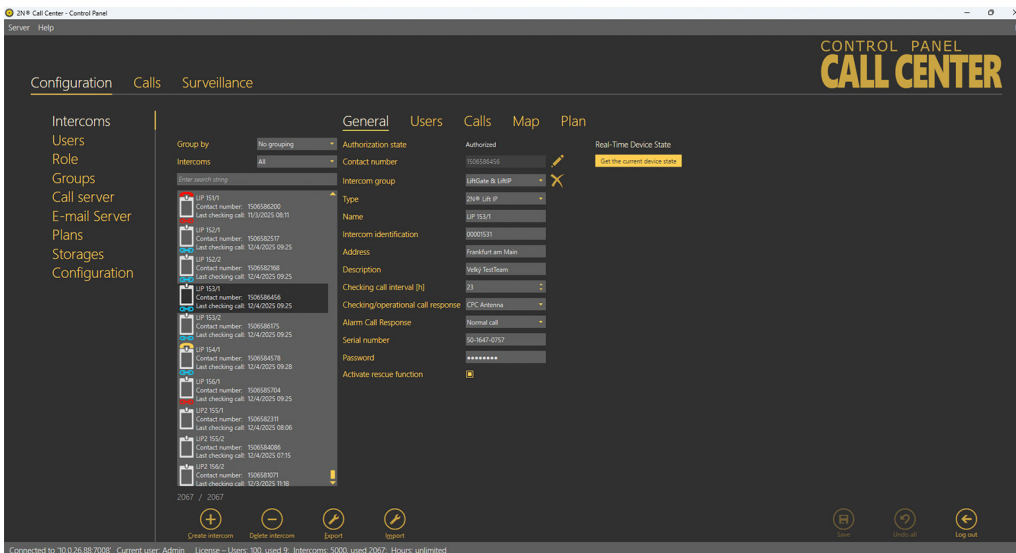

918700E 2N Communicator

Designed for the Elevator shaft communication mode

The 2N Lift8 Communicator application is intended for receiving alarm calls by the control room.

Product Description

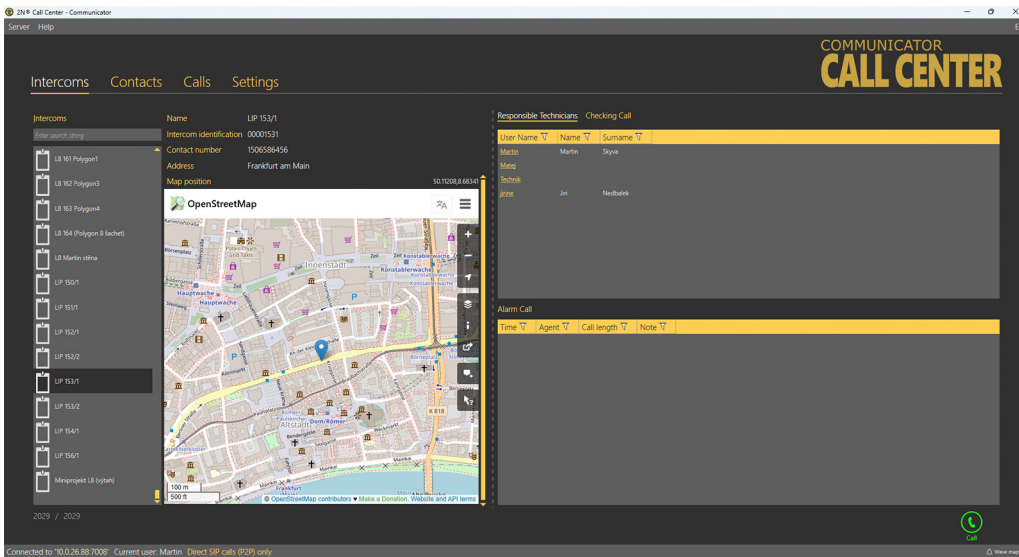

918700E 2N Lift8 Server

The 2N Lift8 Server application processes checking calls and mediates communication between the CUs and PC applications.

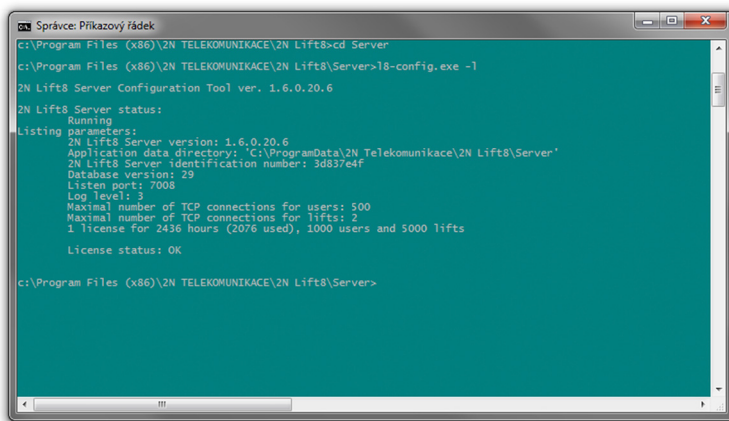

Associated 2N Products

918655E 2N Lift8 – External Pictogram Driver

Transforms the 2N Lift8 cabin LED outputs into universal pilot lamps.

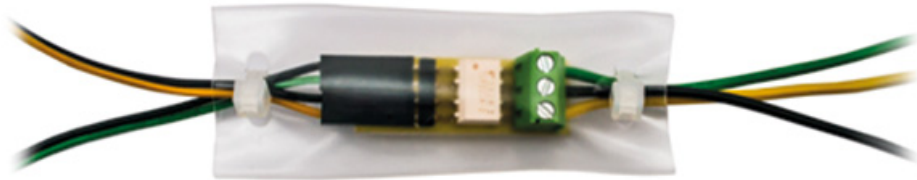

1120102 2N IP Phone D7A

- Designed for the Evacuation mode
- Simple operation
- Provides two-way communication with the persons at the audio units
- HD quality video calls



Upgrade

The table below summarizes the changes made in each version.

Manual Version	Description of Changes
1.0.0	In firmware 1.0.0 <ul style="list-style-type: none"> • Basic version
1.5.0	In firmware 1.5.0 <ul style="list-style-type: none"> • Parameters for VoIP added • Possibility to set the internal splitter for a version with four elevators (up to 4 cabin units identifying themselves as elevators 1–4 can be connected to the internal splitter) • Intercom function
1.6.0	In firmware 1.6.0 <ul style="list-style-type: none"> • Fireman • I/O modules (inputs only) • Adjustable battery capacity • New protocols for alarm calls (shaft and audio unit identification) • Dial-in option (applicable to PSTN module for non-standard tones) • Language support: CZ, EN, RU • Important warning – server database upgrade from version 1.5.x to version 1.6.x • Supervision mode in Control Panel • Improvements in apps
1.7.0	In firmware 1.7.0 <ul style="list-style-type: none"> • Camera module • New CPC Antenna/KONE 2N ext. and P100 2N ext. protocols (shaft and audio unit identification) • DE language support • Auto-deleting records from the archive
1.8.0	In firmware 1.8.0 <ul style="list-style-type: none"> • Modified group menu in Control Panel • PT language support
1.9.0	In firmware 1.9.0 <ul style="list-style-type: none"> • RS232 module • Configuration by SMS • System completeness check

Manual Version	Description of Changes
1.10.0	<p>In firmware 1.10.0</p> <ul style="list-style-type: none"> • Audio unit audio test • Service Tool for Android • TLS/SRTP support • MJPG player in Service Tool • Shaft anti-vandal audio unit • Camera module web interface
1.10.11	<p>In firmware 1.10.11</p> <ul style="list-style-type: none"> • New parameter 711 (enabled bands 2G/3G/Auto)
2.1.0	<p>In firmware 2.1.0</p> <ul style="list-style-type: none"> • New processor type • Extension for two-cabin elevators (7 possible shaft and cabin audio unit locations) • Image download app (get-cam-image)
2.2.0	<p>In firmware 2.2.0</p> <ul style="list-style-type: none"> • Event reporting • New actions and script commands • Monitoring statistical data and new character sets on the server • New installers • In-band DTMF • Direct call (call to IP address)
2.3.0	<p>In firmware 2.3.0</p> <ul style="list-style-type: none"> • Server – reception of operational calls • Operational calls (stuck button, audio test error, battery error) • Get-cam-image – option to download an image outside the active call
2.3.1	<p>In firmware 2.3.1</p> <ul style="list-style-type: none"> • Change of the spacers for module mounting • New events (Service Tool)

Manual Version	Description of Changes
2.4.0	<p>In firmware 2.4.0</p> <ul style="list-style-type: none"> • LAN module • Diagnostic package • Modification of button 2 behavior • Current device status and unit monitoring (Control Panel) • Port forwarding (Service Tool)
2.5.0	<p>In firmware 2.5.0</p> <ul style="list-style-type: none"> • CU restart via Service Tool • Monitoring the current HW status (can be set via Service Tool and Control Panel – refer to Subs. 4.8 for more details) • Change of the audio unit audio test • New parameter 029 (enable the use of set 1 if set 2 is empty) • New parameter 987 (LED signaling according to EN81-28) • New parameter 810 (time until next checking call) • New parameter 811 (checking call manual setup) • New parameter 990 (enable operational calls at events) • New parameter 963 (min. button press time for forced/test alarm)
2.6.0	<p>In firmware 2.6.0</p> <ul style="list-style-type: none"> • New parameter 711 (enabled 2G/3G bands) • Change of the range of parameter 983 (1–100)
2.8.3	<p>In firmware 2.7.0</p> <ul style="list-style-type: none"> • New parameter 919 (siren trigger on machine room audio unit) • New parameter 919 (siren trigger on machine room audio unit)
2.8.5	<p>In firmware 2.8.5</p> <ul style="list-style-type: none"> • LTE/UMTS/GSM module • Central Unit indicators for LTE/VoIP modules
2.9.0	<p>In firmware 2.9.0</p> <ul style="list-style-type: none"> • Evacuation mode and evacuation audio units • New parameters 996 (Evacuation mode activation) and 997

Terms and Symbols

The following symbols and pictograms are used in the manual:



DANGER

Always abide by this information to prevent persons from injury.



WARNING

Always abide by this information to prevent damage to the device.



CAUTION

Important information. Non-compliance with the instructions may result in a device error.



TIP

Useful information for easier and quicker use or configuration.



NOTE

Routines and advice for efficient use of the device.

Description and Installation



CAUTION

Installation and setting of this device, including any handling thereof, should only be carried out by duly trained persons.

Central Unit

Central Unit – Description

The **2N Lift8** system is controlled by one Central Unit (CU).

The CU contains an easily replaceable backup battery pack (gel-lead-acid). The CU is responsible for battery charging and status monitoring. The CU indicates the charging state, signal strength, phone line state, bus state and core state via five color LEDs. The CU is also equipped with a USB interface for comfortable configuration, voice message recording and software upgrade.

The CU (version 3.0 and later) is equipped with an Ethernet port, which provides connection to the network via a fixed data connection (WAN). This data connection provides both data transmission (for remote monitoring of connected devices) and voice communication via VoIP. If the CU is equipped with an LTE/UMTS/GSM module, the Ethernet port can be used for the LAN function.

The CU can be equipped with up to two modules providing more data connection options. These modules can be factory pre-installed in the CU or supplied as separate supplementary accessories.

Description

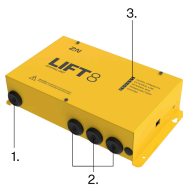

- 1. Supply cable
- 2. Cable inputs/outputs
- 3. Signaling LEDs

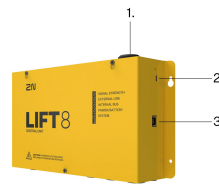

- 1. Antenna cable input
- 2. USB-C port
- 3. Ethernet port

Signal (SIGNAL STRENGTH)

green

strong signal

yellow

medium signal

red

weak signal

no light signaling

in case of PSTN

The signal can flicker between the individual bands (strong – medium, medium – weak).

According to mobile network (valid for modules with LTE):

2G	illuminated
3G	fast flashing
4G	slow flashing

EXTERNAL LINE – for modules without LTE:

green	line all right and ready
green, flashing	call in progress
red permanently illuminated	PSTN in failure, VoIP not registered

EXTERNAL LINE – valid for modules with LTE:

At relax:

green, light on	4G + VoLTE available (IMS active)
yellow, light on	VoLTE unavailable and VoIP inactive
yellow – green (1 s – 1 s)	active VoIP, i.e. SIP and 4G registration active at the same time

Call:

green, flashing (1 s – 1 s)	VoLTE
yellow, flashing (1 s – 1 s)	2G/3G voice channel
green – yellow – no light (0.5 s – 0.5 s – 1 s)	VoIP

Error States:

red, slow flashing (1 s – 1 s)	SIM not inserted
red, fast flashing (0.5 s – 0.5 s – 0.5 s – 0.5 s)	invalid PIN
red, light on	The call cannot be set up or the device does not work as configured (e.g. unregistered module, SIP, etc.).

Bus status (INTERNAL BUS)

green	bus all right and in standby
green, flashing (slow)	voice communication (alarm or triphony)
yellow, flashing	some audio units in an upgrade process, some ready for a call
yellow – green	audio units waiting for upgrade + call in progress
red	The current configuration does not correspond to the saved configuration.
red, flashing	wrong audio unit audio test / no audio unit connected

Battery (POWER/BATTERY)

green	power OK, battery charged
green, flashing	battery charging
yellow	power failure, battery in operation
yellow, flashing	less than 1 hour battery operation left
red	battery disconnected
red, flashing	battery defect – replace

Kernel state (SYSTEM)

green	kernel OK
green, flashing	system launching (the other LEDs start to flash)
yellow	bootloader launching
yellow, flashing	internal package upgrade in progress
red	HW activation (immediately after switching on), core error (logs can be downloaded)
red, flashing	HW has to be serviced (it is impossible to download logs and the bootloader has a fault)
green – red	no checking call made, invalid configuration, system file missing
turquoise	firmware update

Layout of Elements on Central Unit Board

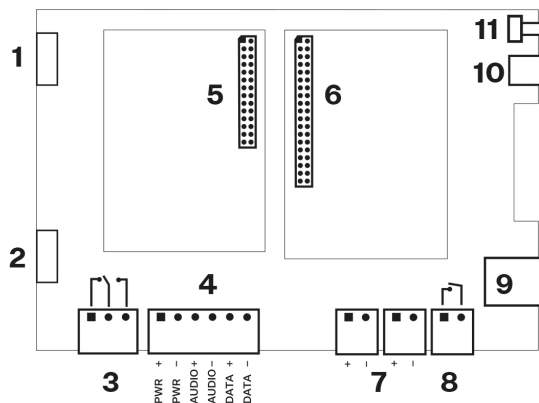

1. 29.2 V / 1 A
2. Battery pack connection
3. Elevator blocking contact (OK position)
4. Main bus
5. Left module bus
6. Right module bus
7. Audio unit bus (2 connectors)
8. Tamper contact (closed when cover closed)
9. Ethernet port
10. USB-C port
11. RESET button

Reset Button Function

- Device Reset – press the button quickly.
- Factory Default Reset – press and hold the button until all the LEDs turn red. Then release the button and wait until the SYSTEM LED flashes yellow. Now press the button quickly. All the user settings will be deleted.
- Zero backup rechargeable battery life counter – press and hold the button until all the LEDs turn red. Then release the button and wait until the POWER/BATTERY LED flashes yellow. Now press the button quickly. Perform this function after replacing the backup rechargeable batteries with new ones only!

- Check system completeness – press and hold the button until all the LEDs turn red. Then release the button and wait until the INTERNAL BUS LED flashes yellow. Now press the button quickly. The system will supervise all the installed equipment from now on (splitters, audio units, etc.) for proper connection and function. Refer to [ALARM Button Test \(p. 187\)](#) for more details.

USB Port Connection



TIP

Do not keep your PC connected for a long time unless necessary to reduce the computer damage due voltage surge from the telephone line during storms, for example.

Central unit – Mechanical Installation

Before You Start

CU Installation Conditions

- The Central Unit (hereinafter referred to as CU) is not intended for outdoor use.
- Do not install the CU onto vibration-producing machines or structures.
- Ensure sufficient air flow while installing the CU for cooling purposes (never cover the CU with any cloth or install it in another closed box).
- You may install the CU into the elevator switchboard unless the temperature exceeds the acceptable limit. Remember that a higher ambient temperature reduces the life of the backup rechargeable batteries in the CU.
- It is recommended that the CU is operated in the vertical position with the cable openings at the bottom. Such mounting position ensures the lowest temperature and thus a longer life of the rechargeable batteries. Horizontal mounting is also possible. The vertical position with the cable openings at the top (upside down) is forbidden!
- After mounting the CU, check that the equipment is firmly fixed in place and cannot come loose and fall into the shaft.

Product Completeness Check

Check whether the product package is complete before installation:

- 1 Central Unit
- 1 main bus connector terminal
- 4 bus connection terminals
- 4 wall dowels
- 4 dowel screws
- 8 cable ties
- 1 battery connecting cable
- Brief Manual
- Warranty Sheet
- drilling template

CU Mounting

It is recommended that the CU is installed in a room that is secured against unauthorized persons, such as the machine room, switching station, etc. An easily accessible place is exposed to a risk of phone line misuse or SIM card misappropriation.

The CU is mounted on a wall with the included wall dowels and screws.



CAUTION

The CU is designed for multi-shaft building installations and cannot be shared by multiple buildings.

Central Unit – Electrical Installation

Putting in Operation

Follow the instructions below for putting the CU in operation:

1. Keep the CU disconnected from the mains.
2. Top cover removal:
 - a. Loosen the three screws on the upper cover of the CU.
 - b. Move the upper cover of the CU in such a way that you can remove it.
 - c. Proceed with caution while removing the cover, be careful about the grounding wire connecting the cover with the CU bottom part. Do not disconnect the wire unless necessary!
3. Connection of components:
 - a. Using the slide-on terminals supplied with the device, interconnect the audio units, splitters (if there 2 or more elevator shafts) and other components of the system with the CU. Mind the polarity!
4. Module Installation
 - a. If the modules are not installed on the CU from the factory, mount them. Doing so, follow the instructions provided in the User Manual for each module.
5. Battery Pack Connection
 - a. Take the rechargeable batteries out of the package and place them into the CU as instructed. Fix them into the holder and use an 8 mm spanner for tightening. Interconnect the batteries using the included cables but do not connect them to the CU.
 - b. Connect the battery cables to the CU motherboard.
6. Replace the upper cover on the CU and tighten the cover fitting screws. Make sure that the grounding wire is connected with the cover while replacing the cover!
7. Reset the backup battery lifetime counter:
 - a. Press and hold the **RESET** button until all the LEDs turn red.
 - b. Release the button and wait for the LED POWER/BATTERY to flash yellow.
 - c. Press the **RESET** button briefly.
8. Connect the CU to the mains supply.



CAUTION

If you connect one elevator shaft only, it is unnecessary to connect the splitters. Use the splitters only if you want to connect 2 or more elevator shafts.



WARNING

- WARNING! The live parts are exposed after the Central Unit cover is removed!
- Be very careful and never touch the dangerous live parts!
- Never work with a switched-on CU with its protective cover off unless you are an authorized person duly trained according to Decree 50/1978 Coll.
- Never insert damaged batteries. Do not insert the batteries in the CU that might show electric or mechanical damage.
- Never use **2N Lift8** without its protective cover to avoid electric accident, malfunction due to wrong interconnection and/or **2N Lift8** electronics damage or destruction as a result of electric short-circuit or adverse environmental conditions. It is because **2N Lift8** is not protected against dangerous touch and water – IP00.
- Make sure before installation that the **2N Lift8** board is not damaged!
- Do not connect devices other than the approved ones. Unapproved devices may cause electrical accident or device damage.

Power Supply

The CU is powered by 100–240 V mains supply.



WARNING

Never connect an AC power supply or an unstabilized DC power supply. This may damage the CU.

Battery Pack Connection and State Check

Connection procedure:

1. Keep the CU disconnected from the mains.
2. Loosen the three screws on the upper cover of the CU.
3. Move the upper cover of the CU in such a way that you can remove it.
4. Proceed with caution while removing the cover, be careful about the grounding wire connecting the cover with the CU bottom part. Do not disconnect the wire unless necessary!
5. Interconnect the rechargeable batteries, but do not connect them to the motherboard.
6. Plug the CU power cable into a 230 V socket.

- Now interconnect the batteries with the motherboard using the FASTON cable (see the figure below). Keep the wiring polarity.

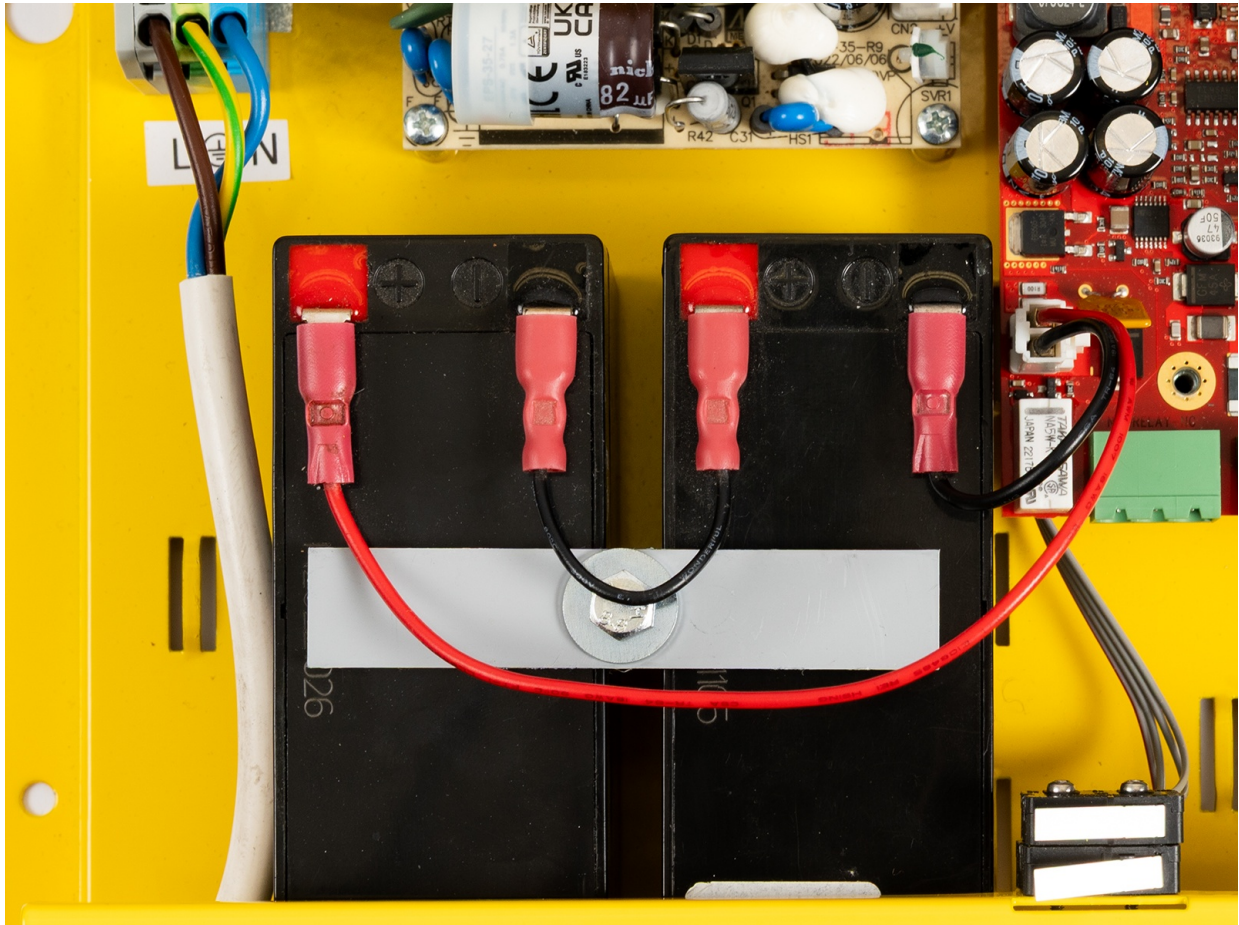

- Replace the upper cover on the CU and tighten the cover fitting screws. Make sure that the grounding wire is connected with the cover while replacing the cover!

After plugging the CU into the socket, the LED (Power/battery) should start to flash (charging). The CU charges the rechargeable batteries until fully charged. After some time, the flashing green LED (charging) should change to a permanently illuminated green LED (battery charged).



WARNING

Maintain the battery pack polarity! When the polarity of the batteries is reversed, there is a danger of fire or explosion or damage to the CU electronics.

Rechargeable Batteries



CAUTION

- If backup rechargeable batteries are used for the **2N Lift8** power supply, the required backup of up to 1 h is guaranteed only if up to 20 audio units are connected in the system.
- The required 1h backup operation is not required in larger installations.
- Remember to replace the batteries every two years to ensure the power outage backup.

Central Unit – Bus Wiring

Splitter – CU Bus Wiring

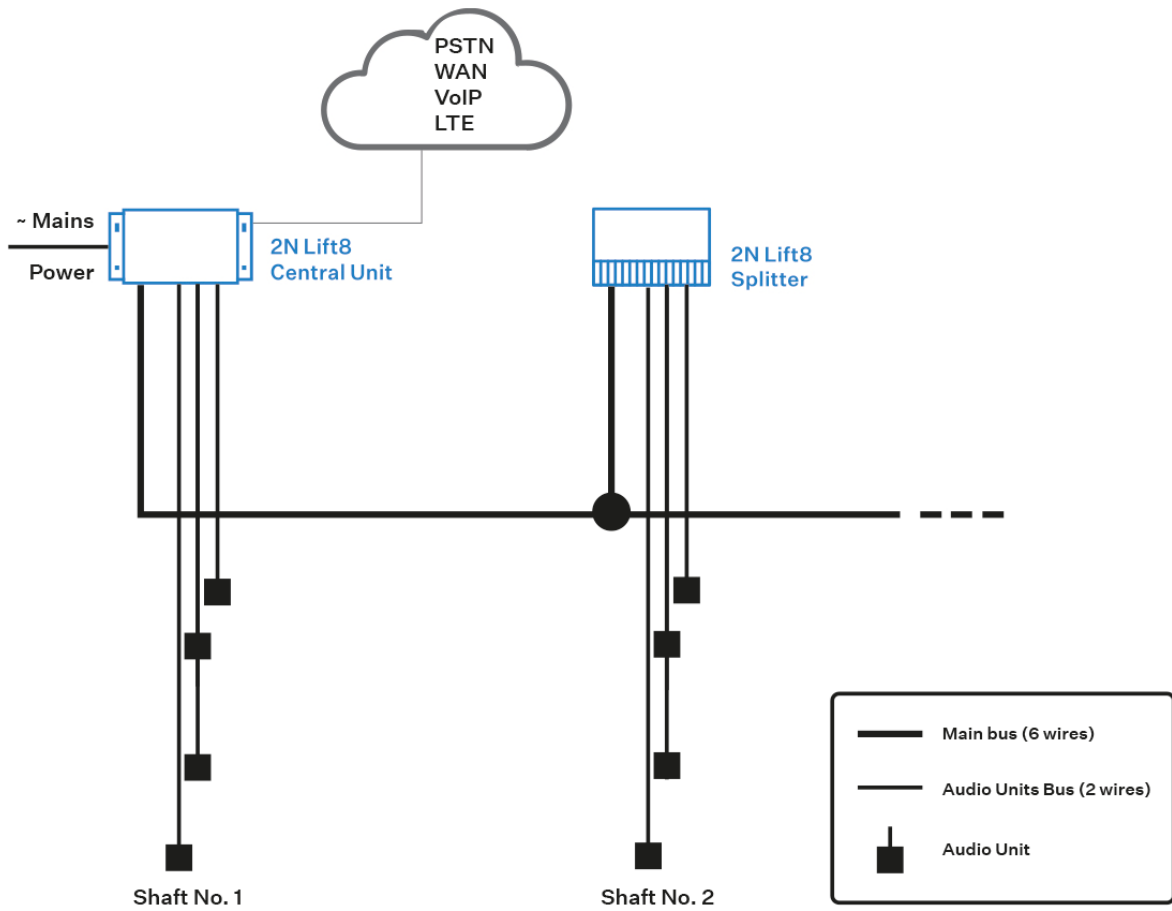

Interconnect the CU and splitter using a 6-wire main bus (power + - , audio + - , data +). Mind the polarity.

1. Main bus power +
2. Main bus power -
3. Main bus audio +
4. Main bus audio -
5. Main bus data +
6. Main bus data -

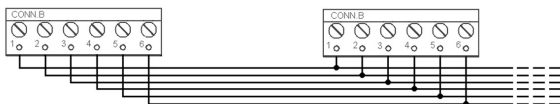



WARNING

6-wire

- The maximum total cable length is 30 m with the cross-section of 0.75 mm².
- For higher lengths, enlarge the supply pair cross-section – PWR (60 m – 1.5 mm² or 100 m – 2.5 mm²).

Audio Units – Splitter Bus Connection

The Central Unit contains an internal splitter to which up to 8 audio units can be connected. The splitter has 2 terminal blocks ready for connecting audio units.

Interconnect the splitter (CU) and the audio units using a two-wire bus. Mind the polarity.

1. Remove the push-in terminal board from the audio unit connectors and connect a two-wire.
2. Connect no more than 4 audio units to one terminal board.
3. Maintain the polarity to make the audio units work properly. Refer to the splitter and audio unit labels for the correct polarity.

1. Bus for Audio Units +
2. Bus for Audio Units –

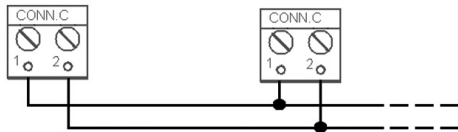

Wiring Requirements:

- The maximum length of the two-wire circuit connected to one splitter is 600 m, including all movable parts (towing cable).
- Where a towing cable is used, use the neighboring cables and make sure that the nearest neighboring conductors are not a source of interference. If shielded cables are used, connect the adjacent conductors with the shielding.
- If shielded cables are used, connect adjacent conductors to the shielding.
- Do not lead the bus in a close vicinity of power cables, via a long distance in particular.
- It is not advisable to lead the bus near the wires connected to the elevator drive.
- You can branch the bus, especially to shorten the total length of all sections.

- A shielded cable is recommended in the case of increased interference. With a shielded cable, the shielding should be continuously connected along the entire cable route. The shielding must be connected to a suitable ground point, preferably to the Central Unit grounding.



TIP

Should bus communication problems occur, check the connection between the audio unit and the splitter (on the CU) using a two-wire lead via an alternative route far from potential interference sources.



CAUTION

The bus is electrically isolated from the telephone line circuits according to the EN60950 standard requirements and its low voltage cannot cause any electrical accident.

Terminating Resistor

The terminating resistor is connected to the first and last device connected to the bus. The terminating resistor can be connected to the Central Unit, splitter or I/O module.



CAUTION

Find the 2-pin terminating resistor connector between the main bus connector and audio unit connectors (see the figure below).

By default, the terminating resistor is connected (jumper mounted).

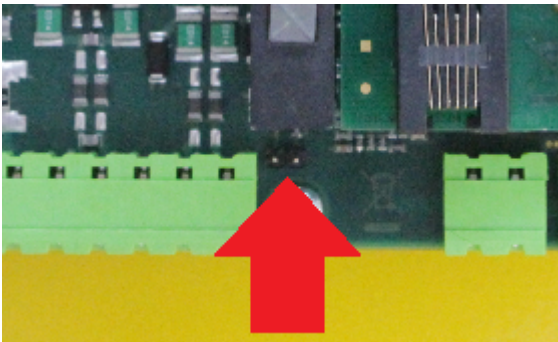

Examples of Connection

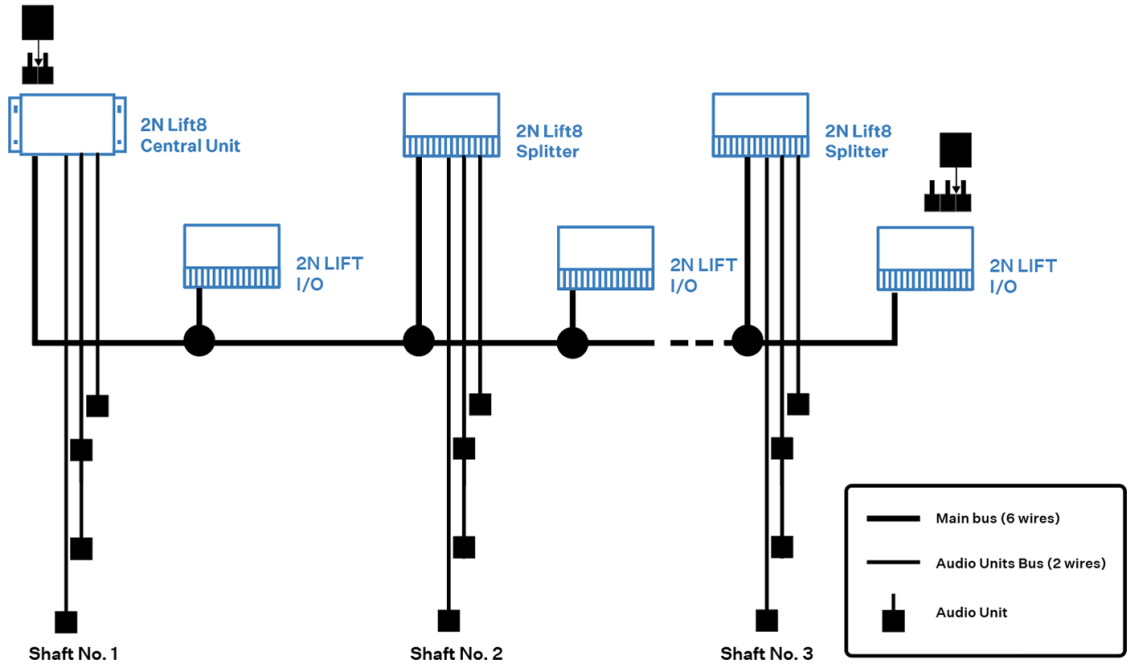

Description and Installation

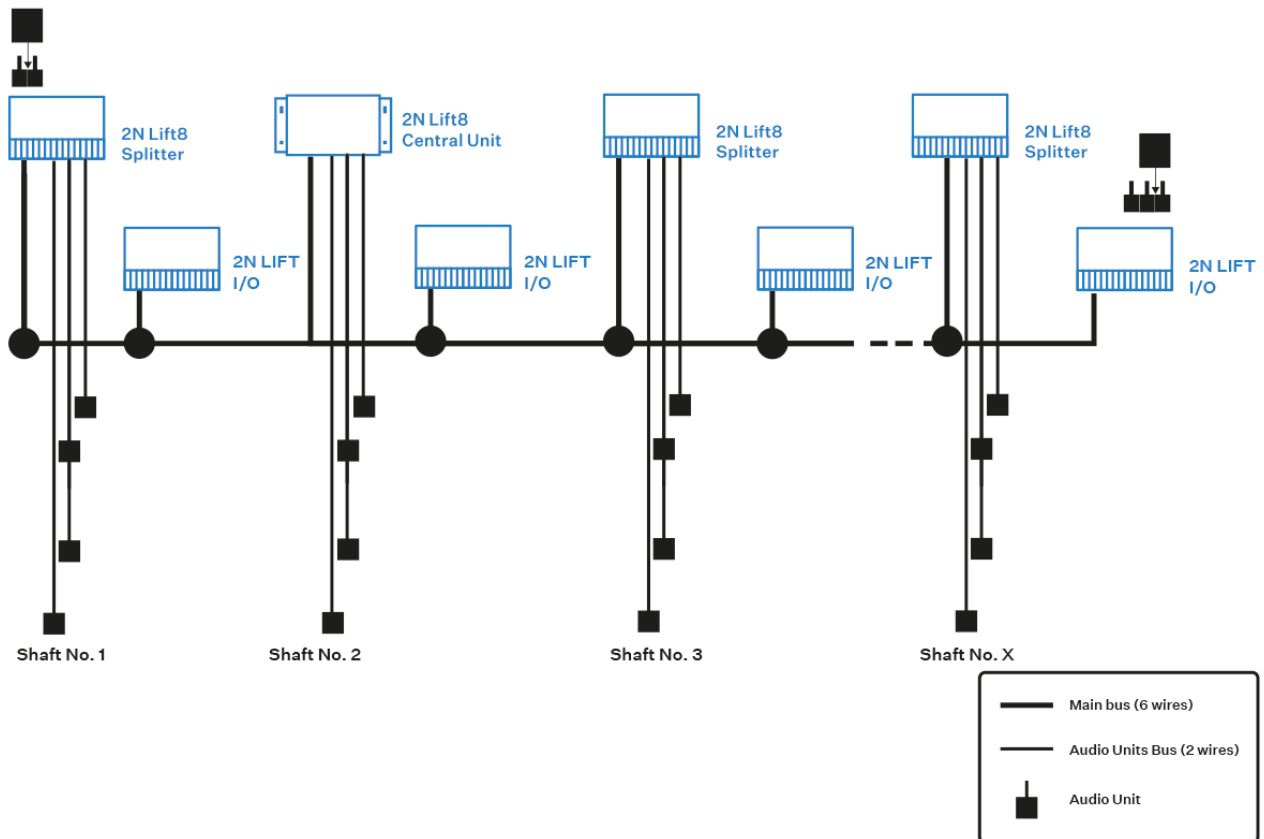

Elevator Blocking Function Connection



CAUTION

The function is not intended for use in the Evacuation mode.

This function may be mandatory depending on the regulations applicable in the country at the time of installation.

The elevator blocking contact opens in the case of a phone line failure or before the complete discharge of the **2N Lift8** Central Unit batteries.

Connect the contact to the relevant input of the control electronics of the elevator/group of elevators. The control electronics must ensure that the elevators in operation go down to the nearest station and the doors open after the contact opens.

Central Unit – Network Connection

CU Connection to Telephone Network

You can connect the CU to a telephone network as follows:

- Ethernet
- LTE(VoLTE)

- PSTN
- UMTS
- GSM
- PBX
- VoIP

PSTN Connection

2N Lift8 works regardless of polarity and line parameters (refer to Technical Parameters). Connect it using the enclosed cable with an RJ-12 terminal. It is the most reliable and simplest connection. The disadvantage is the operating cost (flat rate).



WARNING

Only one CU may be connected to a single telephone line and no other phone terminal may be connected to it.

It is also not possible to connect a product through which the telephone line passes, the so-called priority connection (e.g. ESS).

No dual or party lines may be used.

No telephone “multiplugs” (adapters), even the smart ones, may be used.

Never connect 2N Lift8 to an ISDN line.

Telephone Line Requirements

The line must not be a dual or party line.

The telephone socket and its wiring are usually the network provider's property and may not be tampered with.

Other Recommendations

Notify the telephone network provider of your **2N Lift8** installation and submit certification upon request.

Make sure that your follow-up cables meet the applicable safety regulations.

It is advisable to secure your cabling against pirate connection (with a telephone lock, e.g.).

Connection via PBX (Private Branch Exchange)

This is the least-cost solution where a PBX and an unused PBX line are available.

PBX Line Requirements

The PBX to be used must work reliably even in the case of power outage. Large PBXs are mostly equipped with a back-up power supply, smaller PBXs usually use PSTN line redirection in the event of power failure. Consult the problem with the technician responsible for your PBX. An error during power outage may result in L8 calling an undesired station.

Relevant call access rights have to be assigned to the PBX line to be used (use a standard telephone set to check whether the line can make outgoing calls to all the required numbers).

While programming, enter the necessary PSTN code (typically a zero) or (preferably) make the PBX not require a prefix (so-called automatic connection to the provider's telephone line).

To make the control room – elevator calls, you have to know the extension number and how to get through to it (dial-in, DISA, operator).

The control room – elevator connection may not depend on the operator’s presence; no call forwarding to a fax/answering machine in the night mode is allowed, etc.

Recommendation

Make an agreement with the PBX owner regarding operating costs (**2N Lift8** outgoing calls are billed at the owner’s expense with the exception of free calls via the “green lines”).



TIP

If there is a permanent security guard in your building (security staff, receptionist), train the personnel how to rescue people and program **2N Lift8** to call this service.

Operation without External Connection

2N Lift8 can be used as an intercom during the elevator installation. In this case, it is not allowed to connect the elevator blocking function until the phone line has been connected.

LAN Function

The CU Ethernet port can be switched into the LAN mode. The port is only used for connecting the network equipped devices in the LAN in this mode. The LTE module provides the VoIP connection. Set parameter 998 to switch the Ethernet port from WAN to LAN. Refer to the [System Configuration \(p. 123\)](#) subsection for details.

Splitter

The **2N Lift8** Splitter helps extend installations where the connection of the audio units to the Central Unit is insufficient. It is suitable for cases where it is necessary to connect more than one elevator shaft or more than 8 audio units/floors in the Evacuation mode.

The splitter also contains a make/break contact for the elevator blocking function. There can be up to 7 splitters.

Each splitter must be configured for a different address (elevator shaft number) for the system to work. The address is set as 2–8 (shaft 2–8). Address 1 is reserved for the Central Unit.

Splitters are connected in series. Do not use parallel connection. The **2N Lift8** system would be unstable. The terminating resistor (jumper) is mounted on the last splitter or I/O module (furthest from the CU).

Description

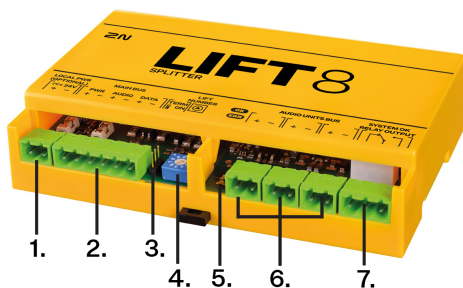

1. Local power (optional)
2. Main bus (Power, Audio, Data)
3. Terminating resistor
4. Splitter address
5. 2 control LEDs
6. 3 terminal boards for audio units
7. NO/NC relay for elevator blocking

Electric Installation

Main Bus Connection



WARNING

Maintain the connection polarity. Otherwise, the **2N Lift8** system will not work.

Remove the push-in terminal board from the main bus connector and connect six wires from the CU. Maintain the polarity (power + -, audio + -, data + -). See the printed figure on the splitter cover.

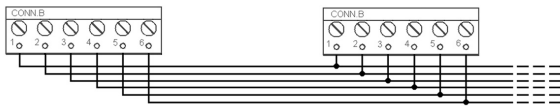

1. Main bus power +
2. Main bus power -
3. Main bus audio +
4. Main bus audio -
5. Main bus data +
6. Main bus data -

Audio Unit Connection

Up to 8 audio units can be connected to one splitter. The splitter has 3 terminal blocks ready for connecting audio units.

1. Remove the push-in terminal board from the audio unit connectors and connect a two-wire.
2. Connect 3 audio unit at most to one terminal board.
3. Maintain the polarity to make the audio units work properly. Refer to the splitter and audio unit labels for the correct polarity.

1. Bus for Audio Units +
2. Bus for Audio Units -

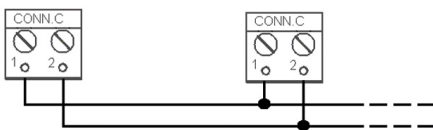

Wiring Requirements:

- The maximum length of the two-wire circuit connected to one splitter is 600 m, including all movable parts (towing cable).
- Where a towing cable is used, use the neighboring cables and make sure that the nearest neighboring conductors are not a source of interference. If shielded cables are used, connect the adjacent conductors with the shielding.
- If shielded cables are used, connect adjacent conductors to the shielding.
- Do not lead the bus in a close vicinity of power cables, via a long distance in particular.
- It is not advisable to lead the bus near the wires connected to the elevator drive.
- You can branch the bus, especially to shorten the total length of all sections.
- A shielded cable is recommended in the case of increased interference. With a shielded cable, the shielding should be continuously connected along the entire cable route. The shielding must be connected to a suitable ground point, preferably to the Central Unit grounding.



TIP

Should bus communication problems occur, check the connection between the audio unit and the splitter (on the CU) using a two-wire lead via an alternative route far from potential interference sources.



CAUTION

The bus is electrically isolated from the telephone line circuits according to the EN60950 standard requirements and its low voltage cannot cause any electrical accident.

Address Setting

Set the splitter address to 2 through 8 using the 10-position switch. The address is set as 2-8 (shaft 2-8). E.g.: For shaft 5, set the switch to position 5.



NOTE

- Do not configure the splitter address as 0, 1 and 9 to avoid an error report from the system.
- Address 1 is used by the Central Unit.

Elevator Blocking Function Connection



CAUTION

The function is not intended for use in the Evacuation mode.

This function may be mandatory depending on the regulations applicable in the country at the time of installation.

The elevator blocking contact opens in the case of a phone line failure or before the complete discharge of the **2N Lift8** Central Unit batteries.

Connect the contact to the relevant input of the control electronics of the elevator/group of elevators. The control electronics must ensure that the elevators in operation go down to the nearest station and the doors open after the contact opens.

Terminating Resistor

A 3-pin termination resistor setting jumper is located between the main bus connection and the elevator number setting.

The jumper is connected to the first and last device (CU, splitter or I/O module) connected to the bus in the position to turn on the terminating resistor, see the figure below.

Refer to the section dedicated to the Central Unit for details on mounting of terminating resistors.

Make sure that the 3-pin jumper is mounted in the off position if the device is not on the first and last bus position; see the figure below.



Termination Resistance ON



Terminating Resistor OFF

Mounting Types Overview

See below for the mounting types and necessary components. Make sure that the installation site is not exposed to flowing or condensed water.



CAUTION

- The warranty does not apply to the product defects and failures arisen as a result of improper mounting (in contradiction with these instructions).
- If the proper mounting instructions are not met, water might get in and destroy the electronics. The splitter circuits are constantly under voltage and water infiltration causes an electro-chemical reaction. The manufacturer's warranty shall be void for products damaged in this way!

Wall mounting

Use the proper wall mounting screws and dowels (not included in the delivery). Hang the device on the wall using the cover bottom holes.

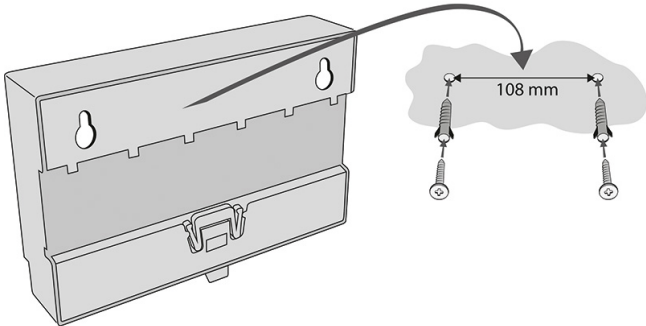

Wall mounting

DIN rail mounting

Mount the device to a standard TS 35 DIN rail. The recommended minimum DIN rail length is 14 cm.

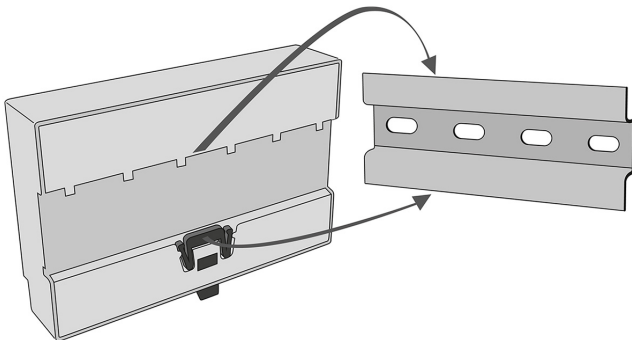

DIN rail mounting

Audio Unit – COP

Description

The user does not come into a direct contact with this product. The control and indication elements depend on the specific installation. The functions of the indication elements correspond to the applicable standards.

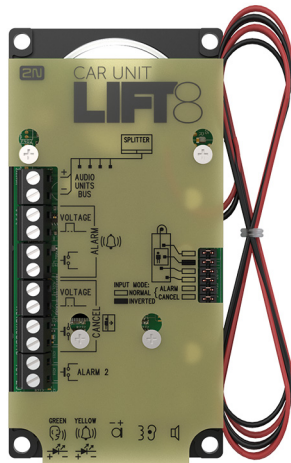

CAUTION

Alarm call

- The yellow LED is illuminated to indicate the call setup progress (request received).
- The green LED is on to indicate call confirmation (connection confirmed).

Upgrade

- The yellow and green LEDs are on (request received and connection confirmed) and the red LED is illuminated on the back side to indicate audio unit initialization.
- The yellow and green LEDs flash to indicate audio unit upgrading. The red LED on the back side is permanently on.
- No LED is illuminated upon upgrade and the audio unit is ready for use.

Before You Start

Installation Conditions

- The panel has to be installation-ready, including speaker perforation.
- The panel must include the following prescribed elements:
 - **ALARM** button;
 - "Request received" illuminated pictogram;
 - "Connection established" illuminated pictogram.
- Make sure that the positions of these pictograms are in accordance with the applicable regulations.
- There must be free space of at least 65 x 130 x 20 mm behind the panel.

Product Completeness Check

Check the product for completeness before installation:

The cabin audio unit package contains (assembled):

- 1 electronics board
- 4 terminals slid onto the board; see the photo
- 1 jumper slid onto the board; see the cover printing
- 1 mounting panel
- 1 speaker connected directly or by cable
- 1 microphone connected directly or by cable
- 1 cover with printing
- 5 cable ties

Mounting

Electronics Mounting

This audio unit is intended for mounting behind the elevator control panel. Typically, the panel is ready for installation as shown in the drawing below:

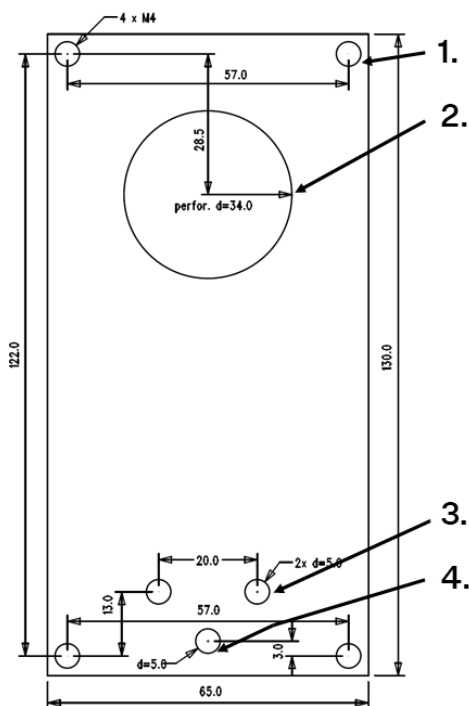

1. M4 threaded weld-on bosses
2. Speaker perforation
3. LED indicator holes (optional)
4. Perforation or microphone hole

Figure: Mounting Hole Dimensions for Audio Unit – COP

To mount the audio unit, you need 4 electrically spot welded M3 or M4 screws, a sufficiently perforated speaker area and a microphone hole. In emergency, you can fix the audio unit on a perfectly degreased surface with a high-quality double-sided foam self-adhesive tape.



WARNING

- Leave no gap between the elevator control panel and the audio unit surface to avoid acoustic speaker fault and acoustic speaker-microphone feedback.
- Do not use this type of audio unit in a position other than mounted on a sufficiently large board. The acoustic properties of an uninstalled audio unit cannot be guaranteed.

Separate Microphone Mounting

If the microphone is supplied separately with a cable on a 25 x 25 mm large board with self-adhesive foil, just glue it directly behind any hole in the panel (one hole must have the minimum diameter of 5 mm, a group of smaller holes must have the same total area). The microphone is glued (from behind) directly to the desired location (remember to remove dust and grease from the surface beforehand!).

Requirements

- The minimum center-to-center distance between the speaker and the microphone is 90 mm. A shorter distance may lead to acoustic feedback. A greater distance (within the available 1m cable) does not matter.
- The microphone must be stuck on so that it does not pick up (even in part!) the acoustic pressure from the space behind the control panel. Such sensing might result in acoustic feedback since the speaker strongly radiates sound into the cavity.

Separate Speaker Mounting

The speaker is equipped with a cable and can be separated from the electronics (simply pulled out) within the reach of the cables delivered (1m). This option is useful where there is not enough space for the whole electronic equipment. Fit the speaker according to the instructions below:

- While gluing the speaker choose such procedures or adhesives that prevent membrane damage by adhesives and volatile substances or heat.
- We recommend that you keep the speaker sealed to eliminate vibrations and provide electrical insulation.

Frequently Asked Questions about Speaker

- Is it possible to use a common speaker for the communicator and floor announcer?

No, it is not possible.

- May I use a speaker of my own?

Yes, but make sure that the impedance is 64 Ω . By doing this you assume responsibility for sufficient volume and frequency range.

- May I place the speaker on the cabin ceiling?

This placement is not recommended.

- May I use a longer cable to the speaker?

For the speaker yes, but we do not recommend it for the microphone.

Electric Installation

Description of Terminals, Connectors and Jumpers

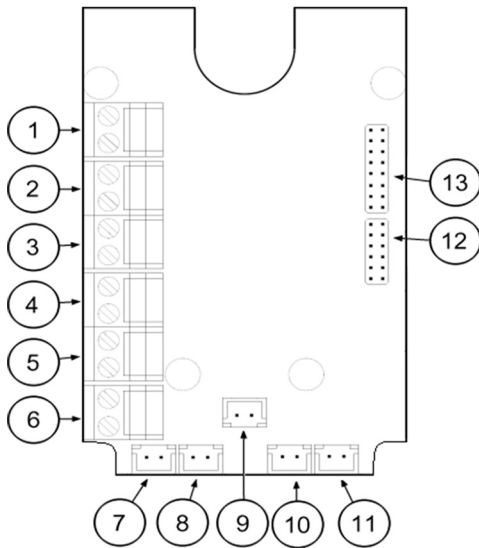

Figure: Terminals, Connectors and Jumpers on Audio Unit Board – COP

Terminals		Connectors	
1	Audio unit bus	7	"Connection established" LED
2	>ALARM, voltage activation	8	"Request received" LED
3	ALARM, contact activation	9	Microphone connector (optionally)
4	CONFERENCE, voltage activation	10	Induction loop connector
5	CONFERENCE, contact activation	11	Speaker connector
6	ALARM 2 (set 2)	13	Service connector
Configuration jumpers		Two LED signal lamps (other side)	
12	ALARM and CONFERENCE input negation	1. (yellow)	Request received
12	unused pins	2. (green)	Connection confirmed



NOTE

If external LEDs are connected to connectors 7 and 8, LED indicators 1 and 2 will not be shining.

Audio Unit Location Configuration

The audio unit is configured as a cabin audio unit by default and so it is not necessary to change the configuration.

To use the audio unit in a room other than the cabin, proceed as follows.

Procedure

1. Reconfigure the jumper on configuration jumper 12.
2. If there is poor access to the pins, you can remove the electronics cover. Slightly loosen the four screws and shift the cover downwards. Now you can remove the cover.
3. The first 4 pins on jumper 12 are used for setting the audio unit position.

Description and Installation

4. Configure the required changes as printed on the electronics cover.

Jumper settings	Location	Jumper settings	Audio unit location
5 <input checked="" type="checkbox"/> 4 <input type="checkbox"/> 3 <input type="checkbox"/> 2 <input type="checkbox"/> 1 <input type="checkbox"/> 0 <input type="checkbox"/>	Cabin 1 roof	5 <input checked="" type="checkbox"/> 4 <input type="checkbox"/> 3 <input type="checkbox"/> 2 <input checked="" type="checkbox"/> 1 <input type="checkbox"/> 0 <input type="checkbox"/>	Cabin 2 roof
5 <input type="checkbox"/> 4 <input checked="" type="checkbox"/> 3 <input type="checkbox"/> 2 <input type="checkbox"/> 1 <input type="checkbox"/> 0 <input type="checkbox"/>	Inside cabin 1	5 <input type="checkbox"/> 4 <input checked="" type="checkbox"/> 3 <input type="checkbox"/> 2 <input checked="" type="checkbox"/> 1 <input type="checkbox"/> 0 <input type="checkbox"/>	Inside cabin 2
5 <input type="checkbox"/> 4 <input type="checkbox"/> 3 <input checked="" type="checkbox"/> 2 <input type="checkbox"/> 1 <input type="checkbox"/> 0 <input type="checkbox"/>	Under cabin 1	5 <input type="checkbox"/> 4 <input type="checkbox"/> 3 <input checked="" type="checkbox"/> 2 <input checked="" type="checkbox"/> 1 <input type="checkbox"/> 0 <input type="checkbox"/>	Under cabin 2
5 <input type="checkbox"/> 4 <input type="checkbox"/> 3 <input type="checkbox"/> 2 <input checked="" type="checkbox"/> 1 <input type="checkbox"/> 0 <input type="checkbox"/>	Shaft bottom		

5. If you have removed the cover, put it back in the original position and tighten the screw.

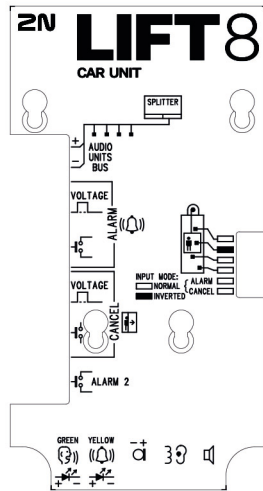

Figure: COP Audio Unit Terminals – Universal



CAUTION

- Up to 8 audio units including a Fireman unit can be connected to one shaft. Up to 5 audio units can be connected to older Central units, refer to [Function and Use \(p. 166\)](#).
- In versions 2.0.0 and higher, up to 7 audio unit positions can be configured for two-cabin elevators:
 1. Cabin 1 roof
 2. Inside cabin 1
 3. Under cabin 1
 4. Shaft bottom
 5. Cabin 2 roof
 6. Inside cabin 2
 7. Under cabin 2
- Up to 2 Fireman audio units can be connected to one shaft from version 2.9.0.



NOTE

- Make sure that no two audio units have an identical address to avoid system error.
- The position-setting jumpers are employed exceptionally, e.g. where a certain audio unit type is used in a position other than normally intended.
- To recover the initial address setting, follow the drawing on the cover.

Bus Connection

Pull the terminal out of the audio unit bus connector 1, connect the audio unit bus wires and replace the terminal to the connector. Mind the polarity.



WARNING

- The audio unit is intended for the **2N Lift8** audio unit bus connection exclusively. Do not connect it to other wires to avoid its damage or destruction.
- Maintain the polarity while connecting the audio unit to avoid the audio unit error.



CAUTION

- The audio unit is fed via a 2-wire bus. Disconnection of these wires results in the audio unit switch-off.
- Avoid the audio unit location duplicity.

ALARM Connection

Requirements

- The **ALARM** button design (color, symbol, keypad surface, mechanical operation) and location have to meet the requirements of the particular installation.

Button control

Requirements

- The **ALARM** button has to be equipped with a make/break (NO/NC) contact that is not connected with any other circuit.
- None of the **ALARM** button terminals may be connected electrically with any other electrical circuit and no voltage source other than the NO/NC contact may be connected to them.
- If one of the **ALARM** contacts is connected to another circuit, an appropriate isolation strength according to the applicable standards has to be ensured between the contacts.

Procedure

1. Leave the **ALARM** terminal in the lower position (3).
2. If you use a make contact, leave the jumper as it is (5th pin on jumper 12) – **ALARM** without jumper fitted (factory setting).
3. If you use an NC contact, fit the jumper (5th pin on jumper 12) – **ALARM** inverted – jumper fitted.

Voltage control

Requirements

- DC 12 to 48 V voltage.
- The voltage signal must be active even during a power failure.

Procedure

1. Move the **ALARM** terminal two pins up into position (2).
2. For activation by voltage connection, leave the jumper as it is (5th pin on jumper 12) – **ALARM** without jumper fitted (factory setting).
3. For activation by voltage disconnection, fit the jumper (5th pin on jumper 12) – **ALARM** inverted – jumper fitted.



WARNING

Ignoring the instructions above may lead to product damage.



CAUTION

- The **ALARM 2** button has the N/O contact only.
- Delayed call (914) and Minimum **ALARM 1** pressing time (962) do not relate to the **ALARM 2** button.
- A short button press (100 ms) sets up a call to the other set of numbers (021–026). If the other set is empty, the call is set up to the first set of numbers (011–016).
- A long button press (3,000 ms) cancels the rescue process if parameter 966 is set.



TIP

Here is an example of wiring of an alarm button with a siren:

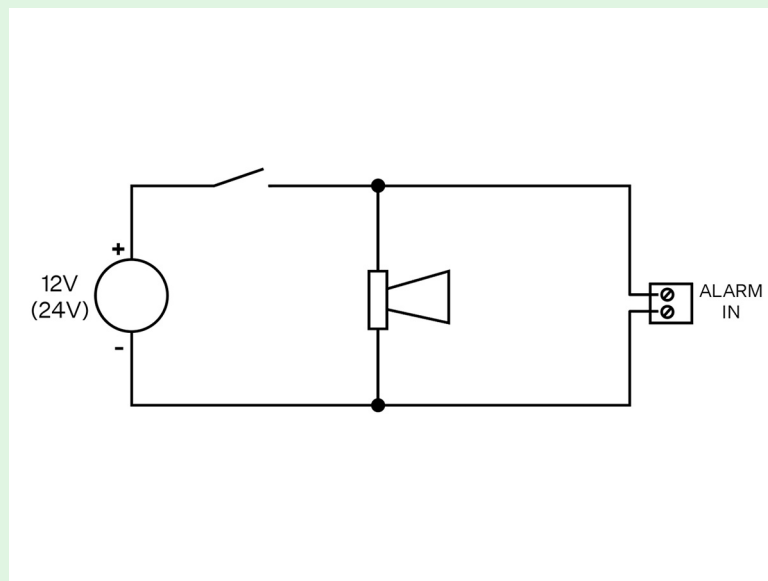

CANCEL input connection (door contact, optional)

This input helps cancel a rescue request if the elevator is fully functional. When the **ALARM** button is pressed, the system waits for a pre-programmed period of time, which is a little longer than the maximum elevator running time. If functional, the elevator arrives in the required station within this timeout and opens the door. In that case, the rescue request is cancelled. If the door does not open, the request is accepted.

Find out before installation whether the door opening signal is available in the elevator cabin.

Requirements

- If the elevator has a double door, the signal must be active only if both the door sets are open, i.e., if it is really possible to leave the cabin.
- The door position signal has to work even in the case of power outage.

Contact Control

Requirements

- None of the contact outlets terminals may be connected electrically with any other electrical circuit and no voltage source other than the NO/NC contact may be connected to the **CANCEL** terminals.

Procedure

1. Leave the **CANCEL** terminal in the lower position (5).
2. If you use an NO contact, leave the jumper as it is (6th pin on jumper 12) – **CANCEL** without jumper fitted (factory setting).
3. If you use an NC contact, fit the jumper (6th pin on jumper 12) – **CANCEL** inverted – jumper fitted.

Voltage Control

Requirements

- 12 to 48 V DC voltage.

Procedure

1. Leave the **CANCEL** terminal in the lower position (4).
2. If you use activation by voltage connection, leave the jumper as it is (6th pin on jumper 12) – **CANCEL** without jumper fitted (factory setting).
3. If you use activation by voltage disconnection, fit the jumper (6th pin on jumper 12) – **CANCEL** inverted – jumper fitted.



WARNING

- Ignoring the instructions above may lead to product damage.
- The **CANCEL** function only works when the cabin audio unit is set to the cabin position (default).



NOTE

- Remember to program delayed calling to make the **CANCEL** connection work successfully.
- Refer to the electronics cover for the **ALARM** and **CANCEL** configuration scheme.

LED Indicator Connection

The current LED technology makes it possible to achieve a relatively good light intensity with a small current. If the elevator indicators are illuminated with a sufficiently efficient LED requiring a current of approx. 5 mA (with diode loss of about 2 V), no power supply is needed. See the figure below for the connection.

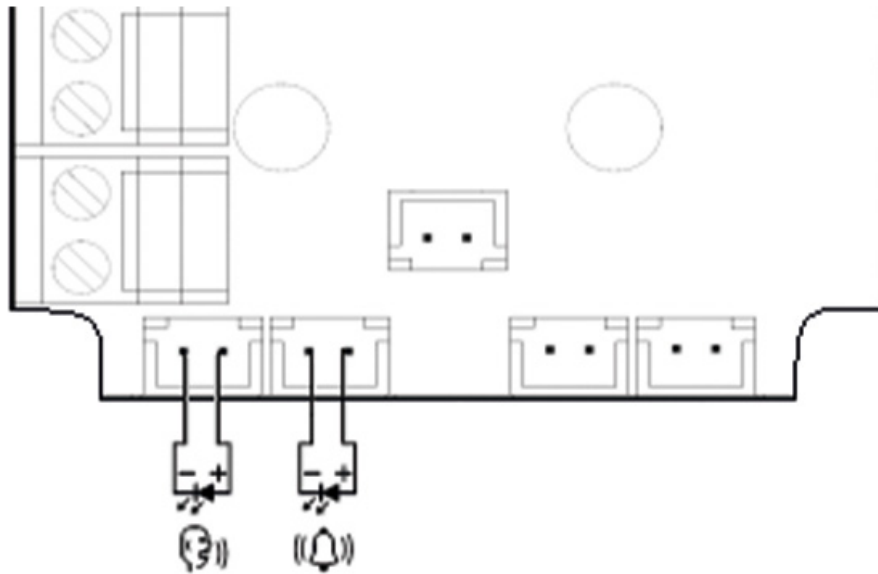

Figure: Alternative LED Connection for Audio Unit – COP



NOTES

- The cables required for this configuration are not part of the standard delivery but are available upon agreement.
- In this configuration, the auxiliary indicators on the PCB are not illuminated.

External Pictogram

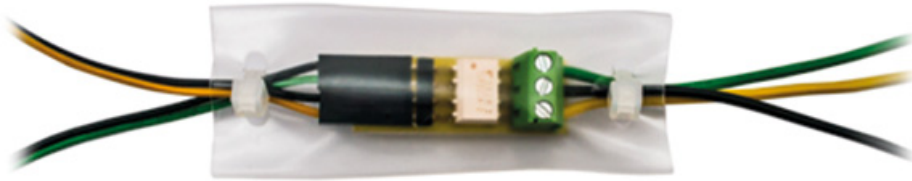

Description

The switch (exciter) of external pictograms is used for converting control signals for two **2N Lift8** COP audio unit LEDs into controlling signal lights with higher consumption. Its outputs are capable of switching two bulbs with max. values of 36 V, 0.5 A. The power switch is capable of switching both DC and AC voltage for bulbs. The outputs are galvanically isolated from the cabin circuits. Always insert the switch in the enclosed insulating tube before installation to protect the circuits from short circuits with other conductive objects!

Diagram

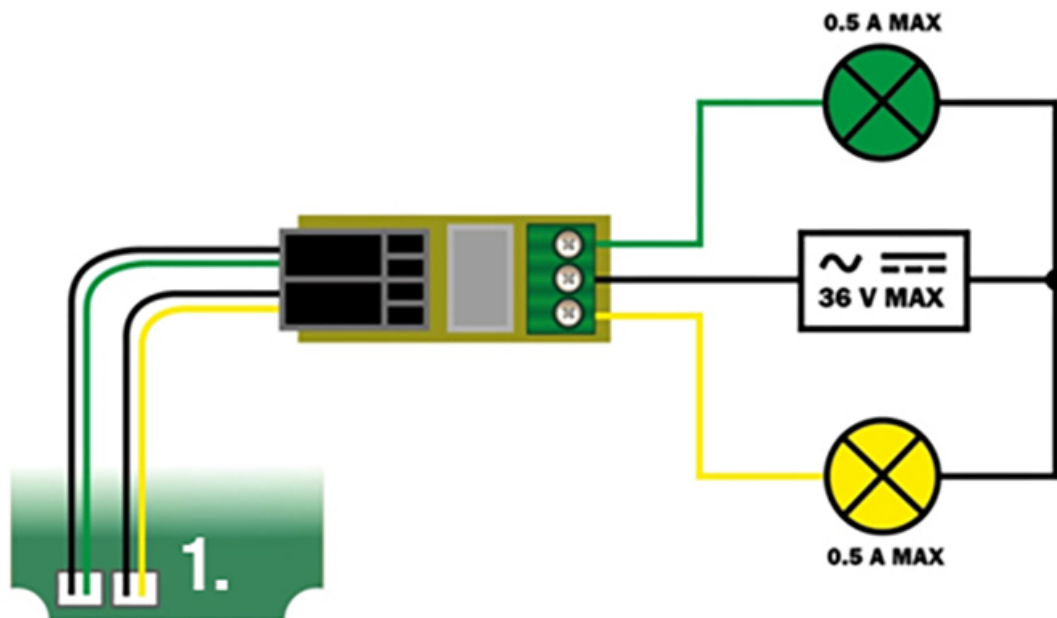
**CAUTION**

- External pictograms are connected to connectors 7 and 8 on the cabin audio unit.
- The manufacturer, 2N TELEKOMUNIKACE a.s., hereby declares that the **2N Lift8** External Pictogram Driver is in compliance with the essential requirements and other relevant provisions of the 1999/5/EC Directive. The Declaration of Conformity is attached to the basic module of **2N Lift8** and also available at 2N.com.

Volume Settings

Slightly loosen the four screws and shift the cover downwards. Now you can remove the cover. Use the trimmer located in the bottom part of the electronics to set the required volume level (see the figure below).



CAUTION

Use the trimmer to set the best acoustic properties eliminating feedback.

Induction Loop Connection

Follow the applicable regulations while mounting the communicator as they might require that the induction loop for deaf people should be a mandatory part of any elevator cabin communicator installation. In that case, connect the loop to the connector (10) with any polarity. If agreed so, the induction loop can be part of the delivery including a 1m cable.

Requirements

- The induction loop has to be placed behind a non-metal, non-magnetic cover in the control panel as the magnetic field of the induction loop cannot go through a metal control panel.
- Make sure that the induction loop is marked with an appropriate symbol (ear) and its position complies with the applicable standards.

Rescue Process

- The rescue (extrication) process is activated after the alarm call ends.
- The yellow LED keeps shining on the audio unit.
- The service technician enters a valid password via the **2N Lift8** voice menu to terminate the process.
- When the rescue password is entered via the voice menu, the yellow LED goes off on the audio unit and the 'Rescue process was terminated' is played.



CAUTION

Access the voice menu (during an incoming call to **2N Lift8** or from the machine room) to terminate the rescue process. Enter the administration menu (9) and press (2) to terminate the rescue process. Enter the shaft number (only if multiple audio units are involved in the rescue process) and enter the rescue terminating password.



WARNING

- Remember to set the rescue password (parameter 992) to activate the rescue function.
- The rescue process can only be activated on the cabin audio unit configured as the cabin (default audio unit setting).

Audio Unit – Machine Room

Description

2N Lift8 Audio Unit Machine Room (Part. No. 918611E). This audio unit is intended for installation in the machine room or as an intercom solution located in the reception. It has some distinctive features compared with the other types:

- The audio unit is equipped with a keypad.
- The keypad helps you select various functions and program the system.
- You can connect a handset to the audio unit for better acoustic properties in noisy environments.
- You can connect an external siren to the audio unit for incoming call signaling.
- You can configure the machine room audio unit to be shared by multiple elevators.



1. Speaker
2. Volume Settings
3. Indication – red flashing – bus connection
4. Door locking screw
5. Protective door
6. Setting pins for common machine room audio unit
7. TRIPHONY button – is not on in the idle state, flashes whenever an alarm call is activated
8. ALARM button – backlit white in the idle state, flashes whenever an alarm call is activated
9. a) "Connection established" indication – green
b) "Fireman connection" / "Voice menu" indication – flashing green
10. a) "Connecting" indication – yellow
b) "Downloading image" indication – flashing yellow



CAUTION

- The yellow, green and red LEDs are on (request received, connection confirmed and red LED under the glass) to indicate audio unit initialization.
- The yellow and green LEDs flash to indicate audio unit upgrading. The red LED is permanently on.
- The **ALARM** pictogram (bell symbol) goes on upon upgrade and the audio unit is ready for use.

Operation

1. This type of audio unit is operated by qualified people (elevator maintenance staff, e.g.).

2. Push the **TRIPHONY** button to activate voice communication with the other audio units of the same elevator. Or, push and hold the **TRIPHONY** button for over 2 seconds to activate communication with another elevator (to display a voice menu and select the required elevator number for **TRIPHONY**).
3. Push the **ALARM** button to call the control room, for example. The audio unit calls the numbers configured in the **ALARM** memory – set 2 (021–026). The **ALARM** button illumination (not required by default) helps you find and activate the audio unit easily in the dark.
4. When you press the **ALARM** or **TRIPHONY** button, the function is called up immediately. Speak handsfree or use a handset for better acoustic properties.
5. Press for more than 2 s to display the voice menu.



CAUTION

- If no number is specified in the **ALARM** memory – set 2 (021–026), the audio unit dials the numbers defined in the **ALARM** memory – set 1 (011–016).
- Push the **ALARM** button to call the control room or machine room audio unit configured as an intercom.
- The **ALARM** and **TRIPHONY** buttons shine even at relax.

Before You Start

Requirements

- Connect a handset supplied by the manufacturer to the audio unit. A different handset may not work.

Product Completeness Check

Check the product for completeness before installation.

- 1 audio unit including the following elements
- 2 wall dowels
- 2 dowel screws
- 7 jumpers for common machine room configuration

Mounting

The audio unit is typically mounted on a wall using the wall dowels and screws included in the delivery.

Electronic Installation

Description of Connectors

There are 3 connectors to the right under the cover:

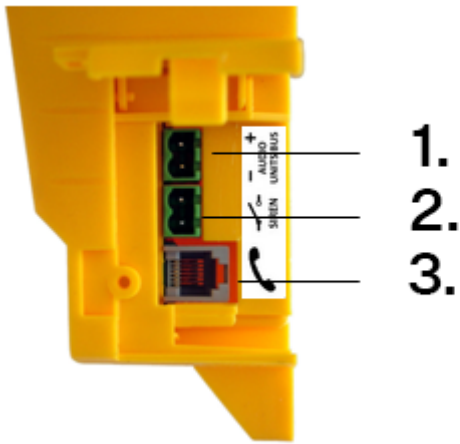

1. Bus connector
2. External siren contact connector
3. Handset connector

Figure: Audio Unit Connectors – Machine Room



TIP

Set the siren function in parameter 919, refer to Subs. [Table of Parameters](#).

Address Setting

There is a group of jumpers under the transparent front cover. Do not use any of them if the machine room is only intended for the given elevator. The audio unit identifies itself as the machine room for the given elevator.

If the machine room is to be shared by multiple elevators, configure the corresponding pins 1–8 for the elevators to share the machine room (numbered 1–8 from left to right 1–8).



NOTE

It is not possible to set a different location for the audio unit. This audio unit is always set as the machine room.

- Group of 8 jumpers for address configuration. If the machine room is shared by multiple elevators, use one audio unit and configure several addresses using the included jumpers. The other audio unit types do not have this possibility!



NOTE

Having set more addresses for the audio unit, press the **TRIPHONY** button to activate communication of the elevator audio units with the lowest of the configured addresses.



CAUTION

Avoid the common machine room audio unit setting duplicity.

Bus Connection

Loosen the screws to the right and open the connector cover. There is a bus connector under it. Pull out the terminal from the connector, connect the wires and replace the terminal. Make sure that the polarity is maintained. Mind the polarity.



WARNING

- The audio unit is intended for the **2N Lift8** audio unit bus connection exclusively. Do not connect the audio unit to other wires to avoid its damage or destruction.
- Maintain the polarity to avoid the audio unit error.



CAUTION

- The proper polarity (+ –) is shown under the door cover.
- The audio unit is powered from the CU or splitter via a 2-wire bus. Disconnection of the audio unit from the bus results in the audio unit switch-off.

Handset Connection

Order an additional handset for your audio unit. The handset is delivered including a cable with telephone end pieces.



CAUTION

- If the handset is not connected, the audio unit works in the handsfree mode.
- A handset of a type other than that supplied by the manufacturer may not work.

Testing

To test the function, connect the handset and press the  button (hold for more than 2 seconds) to enter the voice menu. If the handset does not work, the voice menu will be played from the audio unit speaker.

Volume Settings

Open the protective door on the audio unit and adjust the volume using the trimmer.

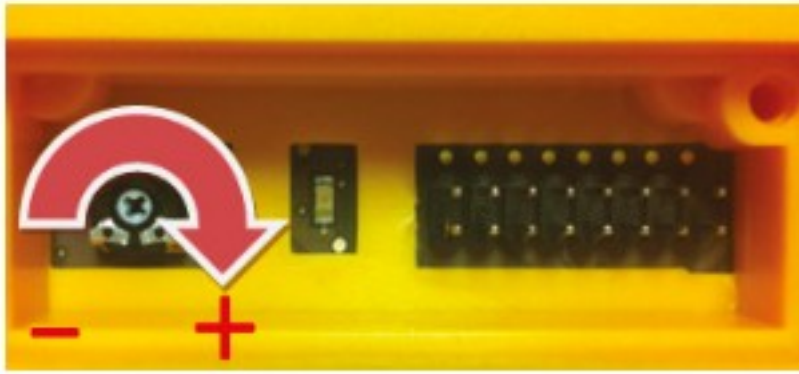

CAUTION

- Use the trimmer to set the best acoustic properties eliminating feedback.
- Volume configuration only works in the handsfree mode.

Audio Unit – Machine Room, PCB

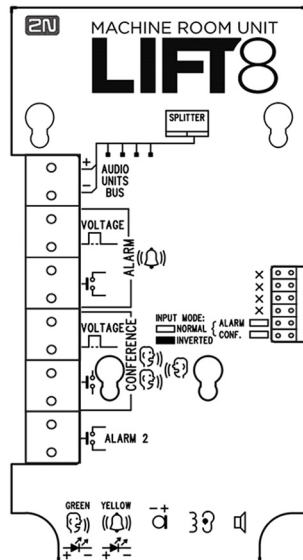

Description

2N Lift8 Machine Room (Part No. 918623E) is an audio unit designed for machine room installation for one elevator shaft or the Intercom solution. The user does not come into a direct contact with this product.

Product Completeness Check

Check the product for completeness before installation:

The cabin audio unit package contains (assembled):

- 1 electronics board
- 4 terminals
- 1 mounting panel

- 1 cover with printing
- 1 speaker connected directly or by cable
- 1 microphone connected directly or by cable
- 1 declaration of conformity
- 1 update notification
- 10 cable ties

Electric Installation

Description of Terminals, Connectors and Jumpers

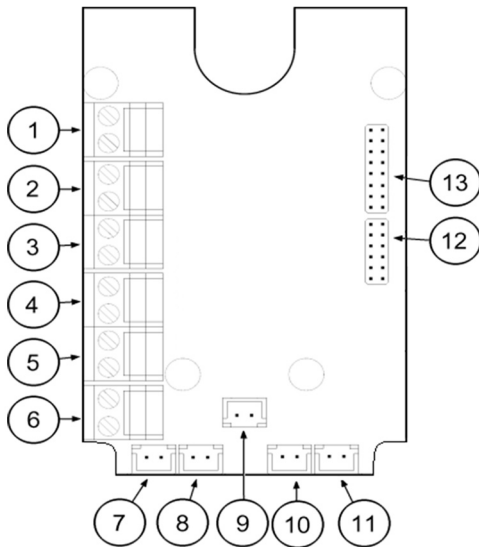

The audio unit is controlled with a button.

Terminals		Connectors	
1	Audio unit bus	7	"Connection established" LED
2	>ALARM, voltage activation	8	"Request received" LED
3	ALARM, contact activation	9	Microphone connector (optionally)
4	CONFERENCE, voltage activation	10	Induction loop connector
5	CONFERENCE, contact activation	11	Speaker connector
6	ALARM 2 (set 2)		
Configuration jumpers		Two LED signal lamps (other side)	

	Terminals	Connectors
12	ALARM and CONFERENCE input negation	1. (yellow) Request received
13	unused pins	2. (green) Connection confirmed

Operation

The audio unit is controlled with a button or voltage.

A call is set up from the numbers defined in the **2N Lift8** parameters. The first **ALARM** memory set includes parameters 011–016. The second **ALARM** memory set includes parameters 021–026. If set 2 is empty, the call is set up according to the set 1 parameters. This is set in parameter 029. If set 2 is empty and parameter 029 is not set, the call is not set up.

- If configured as an intercom, the audio unit can join a **TRIPHONY** call. Press the **ALARM** button to set the function. Connection is made to the audio unit that was the last to generate the **ALARM** function.

Bus Connection

Pull the terminal out of the audio unit bus connector 1, connect the audio unit bus wires and replace the terminal to the connector. Keep the polarity.



WARNING

- The audio unit is intended for the **2N Lift8** audio unit bus connection exclusively. Do not connect the audio unit to other wires to avoid its damage or destruction.
- Maintain the polarity while connecting the audio unit to avoid the audio unit error.



WARNINGS

- The audio unit is fed via a 2-wire bus. Disconnection of these wires results in the audio unit switch-off.
- Avoid the audio unit location duplicity.

ALARM and **CONFERENCE** Button Function

Machine room mode

The **ALARM** button in the machine room mode activates an alarm call to the selected parameter.

The **CONFERENCE** button activates connection with the other audio unit of one and the same elevator, which is indicated by a shining green LED. A repeated press ends the connection.

ALARM 2 helps end the rescue process.

Intercom mode

Set also the following to activate an audio unit in the Intercom mode:

- **ALARM** parameter "#" and the number (1–8) of the shaft in which the audio unit is located, e.g. "#1"
- Call confirmation by pick-up

If another audio unit has activated the **ALARM** function to an audio unit in the intercom mode, the **ALARM** button can be pressed to pick up the call and repressed to terminate the call.

If the audio unit in the Intercom mode has already been called, the **ALARM** button calls back (to the last called audio unit). Otherwise, the call will not be set up. The **CONFERENCE** button ends the call.

The **CONFERENCE** button activates connection with the other audio unit of one and the same elevator, which is indicated by a shining green LED. A repeated press ends the connection.

ALARM 2 helps end the rescue process and receive a Fireman call.

ALARM and **CONFERENCE** Button Connection

Button Control

Requirements

- The buttons must have an N/O or N/C contact that is not connected with any other circuits.
- None of the button outlets may be galvanically connected with any other electric circuit, no voltage may be connected to the terminals – only the contact can be connected.
- If the buttons have multiple contacts and one of them is connected to another circuit, the required standard insulation strength between the contacts must be maintained.
- The buttons must have an N/O or N/C contact that is not connected with any other circuits.

Voltage Control

Requirements

- 12 to 48 V DC voltage.
- The voltage signal must be active even during a power failure.



WARNINGS

- The yellow LED is illuminated to indicate the call setup progress (request received).
- The green LED is on to indicate call confirmation (connection confirmed).



WARNINGS

- The audio unit cannot be configured for calling to the machine room audio unit of any shaft (1–8).
- **ALARM** 2 (021–026) is only used for ending the rescue process and receiving Fireman calls.
- Make sure that the control room audio unit is of the machine room type.

Induction Loop Connection

Follow the applicable regulations while mounting the communicator as they might require that the induction loop for deaf people should be a mandatory part of any elevator cabin communicator installation. In that case, connect the loop to the connector (10) with any polarity. If agreed so, the induction loop can be part of the delivery including a 1m cable.

Requirements

- The induction loop has to be placed behind a non-metal, non-magnetic cover in the control panel as the magnetic field of the induction loop cannot go through a metal control panel.
- Make sure that the induction loop is marked with an appropriate symbol (ear) and its position complies with the applicable standards.

Rescue Process End

Press and hold the **ALARM** 2 button for 3 s to end the rescue process.

Audio Unit – Shaft

Description

This audio unit is designed for installation on the elevator shaft bottom, cabin floor or roof or wherever communication is necessary for elevator maintenance, e.g. The audio unit is enclosed in a robust yellow cover. It is not intended for outdoor use but perfectly tolerates the conditions in elevator shafts: is resistant against fall of small objects, dripping oil, etc. The **ALARM** button activates the control room connection, the **TRIPHONY** button enables conference connection with the other audio units of one and the same elevator. The audio unit contains a built-in microphone and a speaker. A handset can be connected for better acoustic properties. Thanks to its size and robustness, the audio unit has a very good, strong sound.



1. Speaker
2. Volume Settings
3. Indication – red flashing – bus connection
4. Door locking screw
5. Protective door
6. Setting pins for common machine room audio unit
7. TRIPHONY button – is not on in the idle state, flashes whenever an alarm call is activated
8. ALARM button – backlit white in the idle state, flashes whenever an alarm call is activated
9. a) "Connection established" indication – green
b) "Fireman connection" / "Voice menu" indication – flashing green
10. a) "Connecting" indication – yellow
b) "Downloading image" indication – flashing yellow



CAUTION

- The yellow, green and red LEDs are on (request received, connection confirmed and red LED under the glass) to indicate audio unit initialization.
- The yellow and green LEDs flash to indicate audio unit upgrading. The red LED is permanently on.
- The **ALARM** pictogram (bell symbol) goes on upon upgrade and the audio unit is ready for use.

Operation

1. This type of audio unit is operated by skilled persons (elevator maintenance staff, e.g.).
2. Push the **TRIPHONY** button to activate voice communication with the other audio units of the same elevator.
3. Push the **ALARM** button, for example, when someone falls down the shaft.

4. The audio unit calls the numbers configured in the **ALARM** memory – set 2 (021–026).
5. The **ALARM** button illumination (not required by default) helps you find and activate the audio unit easily in the dark.



CAUTION

- If no number is specified in the **ALARM** memory – set 2 (021–026), the audio unit dials the numbers defined in the **ALARM** memory – set 1 (011–016).
- Push the **ALARM** button to call the control room or machine room audio unit configured as an intercom.
- The **ALARM** and **TRIPHONY** buttons shine even at relax.

Before You Start

Product Completeness Check

Check the product for completeness before installation.

- 1 audio unit including the following elements (assembled):
- 2 wall dowels
- 2 dowel screws

Requirements

This audio unit type has no specific requirements.

Mounting

The audio unit is typically mounted on a wall using the wall dowels and screws included in the delivery. There is a drilling template in the product package.



CAUTION

The audio unit is not intended for outdoor installations.

Electronic Installation

Connectors

The audio unit has one connector for bus connection. The second RJ-11 connector is used for handset connection. Both the connectors are under the side doors.

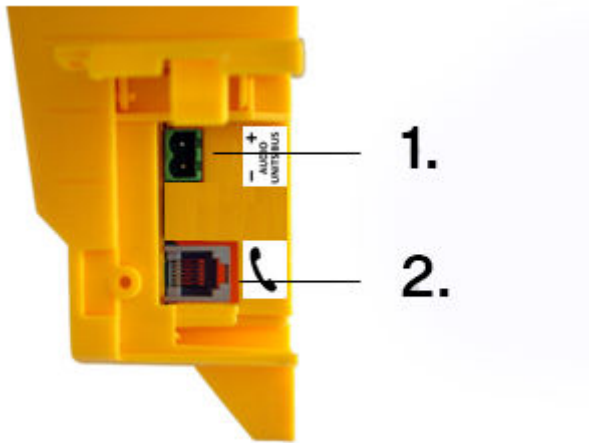

1. Bus connector
2. Headphone connector

Audio Unit Location Configuration

Audio unit location means configuration of jumpers (see the cover print). You do not have to change the jumper configuration if you are installing the audio unit at the shaft bottom.

Otherwise, proceed as follows:

Procedure

1. Loosen the screws on the jumper-protecting door and open the door.
2. Set the audio unit location. If only one cabin is connected, the setting is shown on the print under the door. To set the cabin 2 audio unit, insert the jumper in the shaft bottom position (left jumper) and then select the audio unit position with the other jumper (cabin 2 roof, cabin 2, under cabin 2).
3. Close the door and tighten the screw.



CAUTION

- Avoid the audio unit setting duplicity.
- This audio unit cannot be configured as common for multiple elevators.

Bus Connection

Loosen the screws to the right and open the connector cover. There is just one bus connector under it. Pull out the terminal from the connector, connect the wires and replace the terminal. Mind the polarity.



WARNING

- The audio unit is intended for the **2N Lift8** audio unit bus connection exclusively. Do not connect the audio unit to other wires to avoid its damage or destruction.
- Maintain the polarity to avoid the audio unit error.



CAUTION

- The proper polarity (+ –) is shown under the door cover.
- The audio unit is powered from the CU or splitter via a 2-wire bus. Disconnection of the audio unit from the bus results in the audio unit switch-off.

Handset Connection

Order an additional handset for your audio unit. The handset is delivered including a cable with telephone end pieces.



CAUTION

- If the handset is not connected, the audio unit works in the handsfree mode.
- A handset of a type other than that supplied by the manufacturer may not work.

Volume Settings

Open the protective door on the audio unit and adjust the volume using the trimmer.



CAUTION

- Use the trimmer to set the best acoustic properties eliminating feedback.
- Volume configuration only works in the handsfree mode.

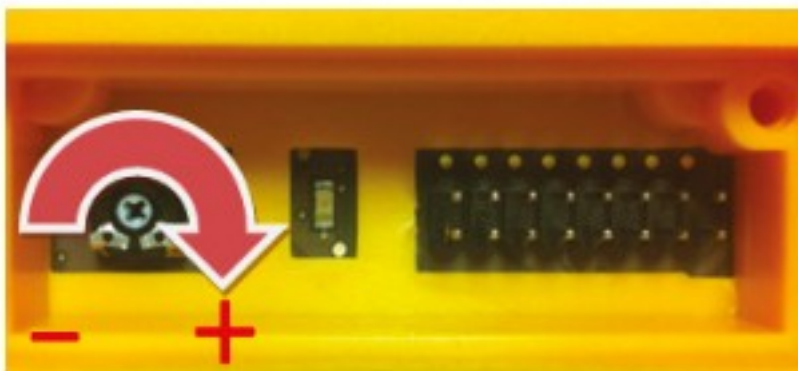

Audio Unit – Compact

Description

Robust, heavy-duty design, equipped with a standard-sized **ALARM** button including signage for the blind and backlit pictograms (hardened glass). Designed for elevator wall mounting. No drilling is required as the device is to be wall-mounted.

1. Speaker
2. Pictogram window (also access to the rotary switch and volume settings)
3. Pictogram indicating the location of the induction coil for the hearing impaired persons
4. "Connection established" pictogram – green (lit even when TRIPHONY is active)
5. "Establishing connection" pictogram – yellow, "Downloading image" indication – flashing yellow
6. "Audio unit bus" pictogram – lights red whenever an error occurs
7. ALARM button
8. Window locking screw hole
9. Microphone hole

Figure: Description of Audio Unit – Cabin Compact



CAUTION

- The audio unit is initializing – yellow, green and red LEDs are on (request received, connection confirmed and audio unit bus).
- The yellow and green LEDs flash to indicate audio unit upgrading, the red LED is permanently on.
- After the upgrade, the **ALARM** button lights up on the audio unit and is ready to use.

Operation

- Press the **ALARM** button to activate the device. The 'Establishing connection' symbol goes on immediately. The 'Connection established' symbol goes on once the communication is set up.

Before You Start

Requirements

- Make sure that the elevator wall is even.
- Make sure that the installation meets the standard requirements (**ALARM** button height and distance from the other elevator buttons, e.g.).

Product Completeness Check

Check the product for completeness before installation:

- 1 Compact audio unit including the following parts (assembled):
 - window with label
 - 3 terminals slid into the back side connector
- 1x long 2 mm ballpoint hexagon key wrench
- 4 M4 x 8 screws
- 4 M4 x 30 worm screws
- 4 M4 nuts
- 4 fan-shaped washers

Mounting

Just drill holes into the cabin wall as shown in the figure below (also see the 1:1 figure on the product box). The larger hole is intended for cable passage. Round the hole edges to avoid cable damage!

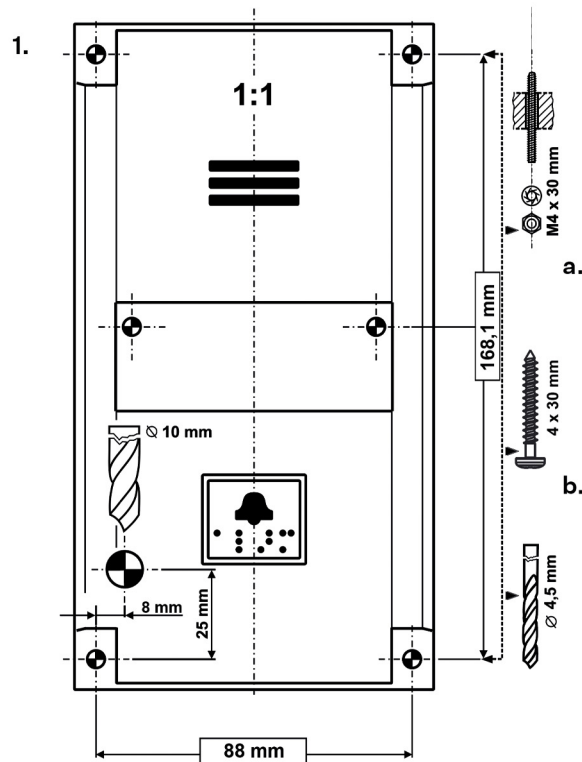

Figure: Mounting Hole Dimensions for Audio Unit – Cabin Compact



NOTE

Two 2.5 mm holes in the symbol window are intended for installations without access to the back side of the installation panel. The 2.5 diameter is suitable for plywood wall mounting (chipboard, laminated plastic, etc.) with the screws included in the delivery. Drill M4-threaded holes for metal panel mounting from the front side.

Do not complete the mounting procedure until connecting the device electrically (see below).

Electric Installation



CAUTION

Be sure to connect the wires before wall mounting. The connectors are separable – remove them, connect the wires, tighten the screws and replace the connectors.

Description of terminals

Terminals		Description	
AUDIO UNIT BUS		Audio unit bus (2-wire) connection, polarity must be maintained	
ALARM terminals	Voltage = voltage control (on/off)	6–24 V DC voltage, any polarity *)	Alarm call activation
	Contact = contact control (on/off)	NO/NC contact *)	
CANCEL terminals	Voltage = voltage control (on/off)	6–24 V DC voltage, any polarity **)	Alarm call deactivation upon door opening
	Contact = contact control	NO/NC contact**)	
ALARM 2 terminal	Contact = contact control (closing)	N/O contact	Activating a call from ALARM memory set 2

*) By default, ALARM is activated by voltage connection or contact closing. Use a rotary switch to apply voltage disconnection and contact opening.

***) By default, ALARM is deactivated by voltage connection or contact closing. Use a rotary switch to apply voltage disconnection and contact opening.



CAUTION

- The ALARM 2 button has the N/O contact only.
- Delayed call (914) and Minimum ALARM 1 pressing time (962) do not relate to the ALARM 2 button.
- A short button press (100 ms) sets up a call to the other set of numbers (021–026). If the other set is empty, the call is set up to the first set of numbers (011–016).
- A long button press (3,000 ms) cancels the rescue process if parameter 966 is set.

Bus Connection

Pull the AUDIO UNIT BUS connector out of the terminal board. Connect the audio unit bus (keep polarity as shown on the audio unit cover) and replace the connector.



WARNING

The audio unit is intended for the 2N Lift8 audio unit bus connection exclusively. Do not connect the audio unit to other wires to avoid its damage or destruction.

Connectors

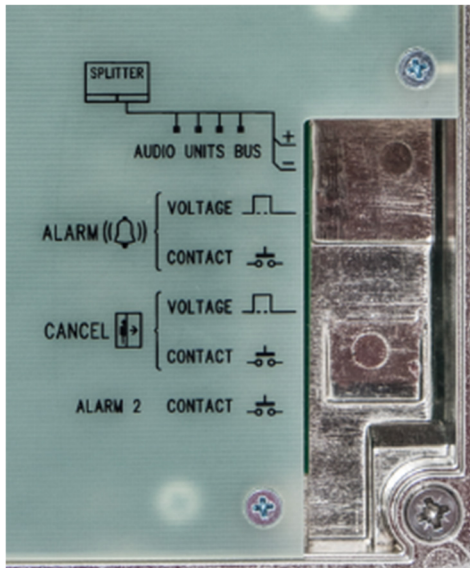

Figure: Connectors on Audio Unit – Cabin Compact (New Type)



WARNING

- Make sure that the minimum button isolation distance is 1.5 mm and breakdown voltage is 1,500 V. The button contacts may not be connected to any other circuits. If such conditions cannot be met, use voltage control.
- You can use the switch on the audio unit front side or closing/opening button connected to the **ALARM** CONTACT connector or both of them if necessary.



NOTE

The **ALARM** button on the cover keeps functional even if an external button is connected.

Rotary Switch

There is a glass-covered rotary switch on the audio unit front side. Use the switch to set **ALARM** / **CANCEL** (normal/inverted input) and audio unit type (cabin, cabin roof, cabin bottom, shaft bottom).

Procedure	Rotary switch positions	Figure
1. Insert the hexagonal spanner (included) in the hole on the product bottom edge (window lock screw) and turn left (about 10 times) until you feel resistance.	1. Position – ALARM normal, CANCEL normal, cabin	
2. The window slides down by itself or with little assistance, showing its upper brim.	2. Position – ALARM inverted, CANCEL normal, cabin	
3. Tilt the window forwards and remove it.	3. Position – ALARM normal, CANCEL inverted, cabin	
4. Set the required address.	4. Position – ALARM inverted, CANCEL inverted, cabin	
5. Replace the window.	5. Position – cabin roof	
6. Insert the hexagonal spanner (included) in the hole on the product bottom edge and turn right about 10 times until the window slides under the panel edge. Tighten the window applying a moderate force.	6. Position – cabin bottom 7. Position – shaft bottom Positions 8, 9, 0 / not used (red bus LED flashing)	

ALARM and **CANCEL** Settings (Rotary Switch)

Contact closing/voltage connection control of **ALARM** and **CANCEL**.

- Set the rotary switch (under the front glass) to position 1 to make **ALARM** / **CANCEL** be controlled by contact closing or voltage connection.

Contact opening/voltage disconnection control of **ALARM**. Contact closing/voltage connection control of **CANCEL**.

- Set the rotary switch (under the front glass) to position 2 to make **ALARM** be controlled by contact opening or voltage disconnection and **CANCEL** be controlled by contact closing or voltage connection.

Contact closing/voltage connection control of **ALARM**. Contact opening/voltage disconnection control of **CANCEL**.

- Set the rotary switch (under the front glass) to position 3 to make **ALARM** be controlled by contact closing or voltage connection and **CANCEL** be controlled by contact opening or voltage disconnection.

Contact opening/voltage disconnection control of **ALARM** and **CANCEL**.

- Set the rotary switch (under the front glass) to position 4 to make **ALARM** and **CANCEL** be set as an N/C contact or a contact activated by voltage disconnection.



CAUTION

- Use 6–24 V DC voltage of any polarity. Make sure that the voltage supply is backed up against power failure.
- Where activation from multiple locations is required, combination with buttons is possible.

CANCEL input connection (door contact, optional).

This input helps cancel a rescue request if the elevator is fully functional. Press **ALARM** to make the system wait for a defined period of time, which is slightly longer than the maximum elevator ride. If functional, the elevator arrives in the required station within this timeout and opens the door. In that case, the rescue request is cancelled. If the door does not open, the request is accepted.

Find out before installation whether the door opening signal is available in the elevator cabin.

Requirements

- If the elevator has a double door, the signal must be active only if both the doors are open, i.e., if it is really possible to leave the cabin.
- The door position signal has to work even in the case of power outage.



NOTE

Remember to program delayed calling to make the **CANCEL** connection work successfully.

Volume Settings

1. Insert the hexagonal spanner (included) in the hole on the product bottom edge (window lock screw) and turn left (about 10 times) until you feel resistance.
2. The window slides down by itself or with little assistance, showing its upper brim.
3. Tilt the window forwards and remove it.
4. Set the required volume level using a trimmer.
5. Replace the window.
6. Insert the hexagonal spanner (included) in the hole on the product bottom edge and turn right about 10 times until the window slides under the panel edge. Tighten the window applying a moderate force.



CAUTION

Use the trimmer to set the best acoustic properties eliminating feedback.

Mounting Completion

Having connected the wires, you can complete the wall mounting. If you can access the cabin wall from the outside, use the mounting type that prevents dismantling and unauthorized tampering from the cabin. This reduces the risk of tampering. Mounting instructions:

- Where access from the outside is possible, use the four pre-drilled M4 holes in the corners.
- Remove the corner covers fitted with four M4 screws from behind.
- Screw the 30 mm long M4 headless grub screws included in the audio unit package in place of the corner cover screws removed. Tighten the screws with an internal hexagon key wrench.
- Put the audio unit on the holes, apply the serrated lock washers from the outside and screw the M4 nuts (both included in the delivery).
- This type of mounting is suitable for an elevator cabin wall thickness of up to 20 mm.

Description and Installation

2a.

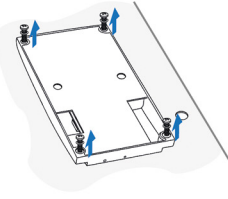

3a.

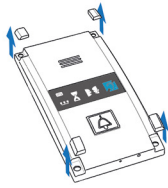

4a.

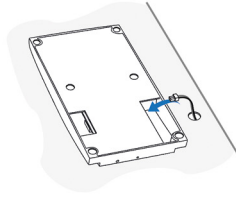

5a.

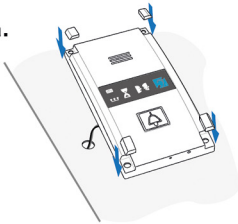

6a.

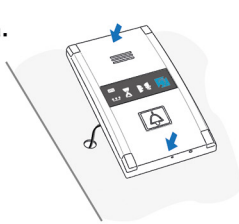

7a.

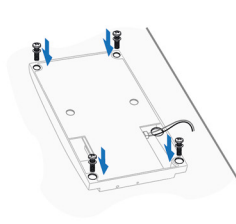

If you cannot access the cabin wall from the outside, use the screws under the pictogram glass:

- Insert the hex key wrench (included in the package) in the hole on the product bottom edge and turn it left (about 10 times) until you feel resistance.
- The window slides down by itself or with little assistance, showing its upper brim.
- Tilt the window forwards and remove it.
- Now you have access to two holes in the window corners. Put the audio unit on the pre-drilled cabin wall holes and fit it with the included screws. These screws are suitable for plywood, chipboard, laminated plastic walls, etc. For other materials, use appropriate screws or M4 screws in the pre-drilled M4 threaded holes.
- Replace the window and insert the hex key wrench in the bottom edge hole turning it right about 10 times until the window slides under the panel edge. Tighten the window applying a moderate force.

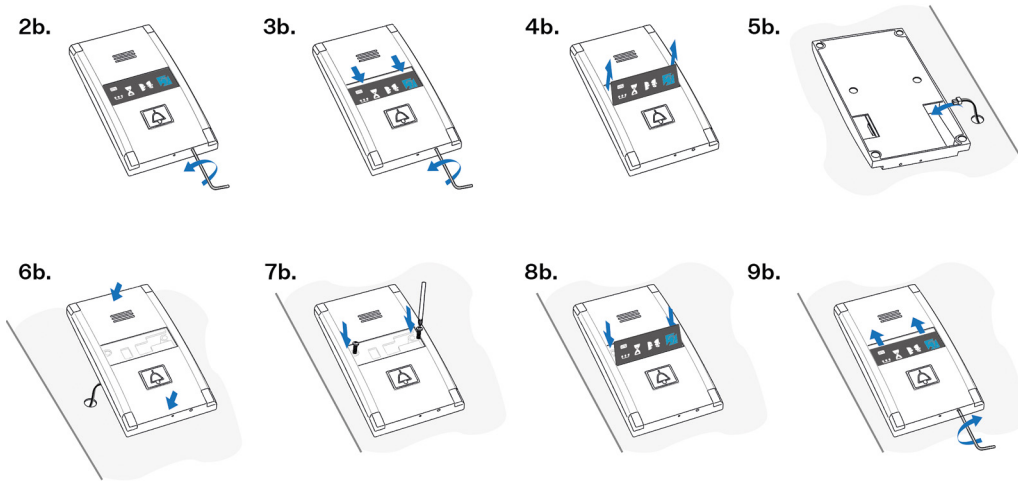

Induction Loop Connection

The induction loop is part of the Compact cabin audio unit. No more accessories are required for the given case.

PSTN Module

Description of Connection

The module should be part of the Central Unit (hereinafter referred to as CU). If the CU does not contain the PSTN module, proceed as follows:

1. Disconnect the CU from the mains supply.
2. Loosen the three screws on the upper cover of the CU.
3. Move the upper cover of the CU in such a way that you can remove it.
4. Proceed with caution while removing the cover, be careful about the grounding wire connecting the cover with the CU bottom part. Do not disconnect the wire unless necessary!
5. Disconnect the back-up rechargeable batteries if available using the battery – CU cable FASTON terminals.

Description and Installation

6. Mount the module on the externally threaded spacers (2) and connect it to the motherboard connector (1).

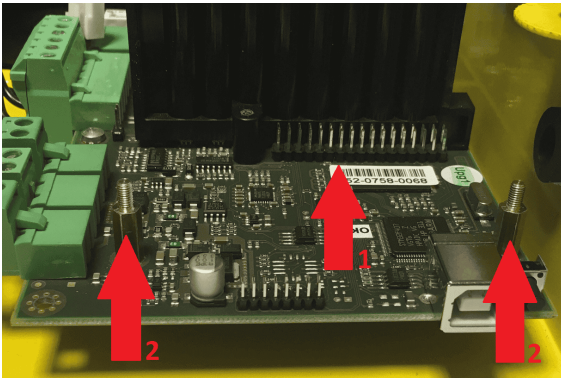

7. Be careful while putting the module on the pins. Make sure that you have connected all the pins to the module connector.
8. If you have mounted the connector pins correctly, use 1 screw spacer (3) and 2 threaded spacers (4) to fit the module. Use a 5mm hex socket wrench to fit the spacers.

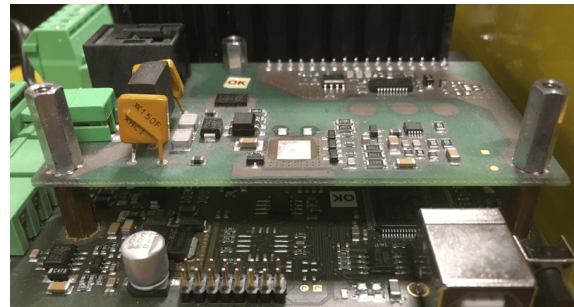
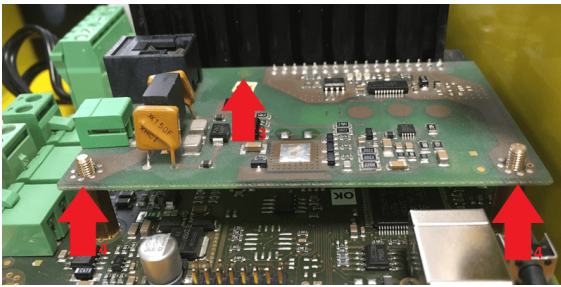

9. Now connect the PSTN line. There are 2 options:
 - a. Using an RJ 11 connector.
 - b. Using a slide-on terminal board.
10. Connect the rechargeable batteries and replace the CU cover. Tighten the 3 screws to fit the cover.
11. Connect the CU to the mains supply.



WARNING

- While mounting the module, make sure that all the pins are fitted correctly into the connector to avoid module damage.
- An incorrect connection can damage the module.



NOTE

A non-standard behavior of the module results in the module restarting automatically to make its functions right. In case the error re-appears after the restart, the restart timeout start to double gradually. The increasing restart timeout ensures that no instantaneous restart upon power up happens repeatedly. If the error is not eliminated even within 63 minutes after the last restart, the Central Unit is restarted.

LTE/UMTS/GSM Module

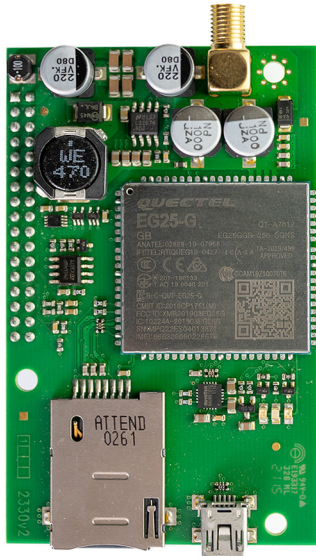

Description of Connection

The module is not part of the CU.

1. Disconnect the CU from the mains supply.
2. Loosen the three screws on the upper cover of the CU.
3. Move the upper cover of the CU in such a way that you can remove it.
4. Proceed with caution while removing the cover, be careful about the grounding wire connecting the cover with the CU bottom part. Do not disconnect the wire unless necessary!
5. Disconnect the back-up rechargeable batteries if available using the battery – CU cable FASTON terminals.
6. Remove the sealing ring from the CU cover.

7. Mount the module on the externally threaded spacers and connect it to the motherboard connector. Be careful while mounting the module: push the antenna connector through the CU cover. This module is connected into the right module bus, see the layout of elements in [Central Unit \(p. 26\)](#).



WARNING

- While mounting the module, make sure that all the pins are fitted correctly into the connector to avoid module damage.
- An incorrect connection may damage the module.

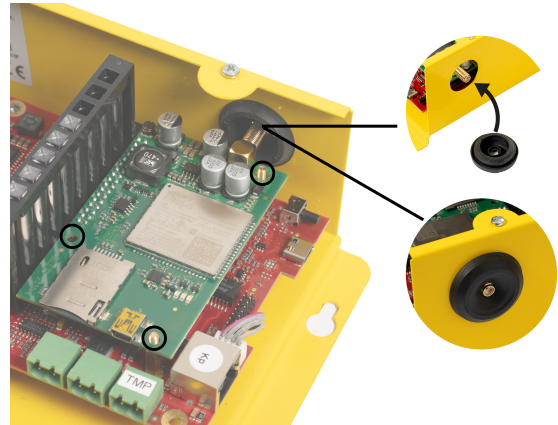
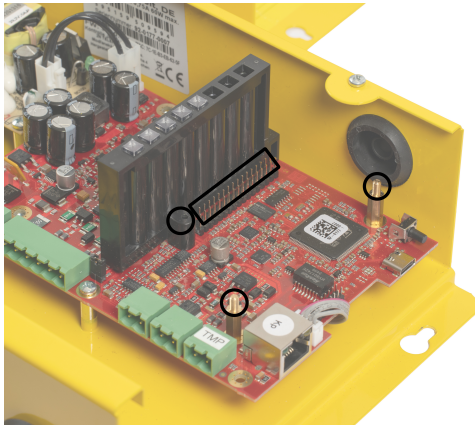

8. If you have mounted the connector pins correctly, use 1 screw spacer and 2 threaded spacers to fit the module. Use a 5mm hex socket wrench to fit the spacers.

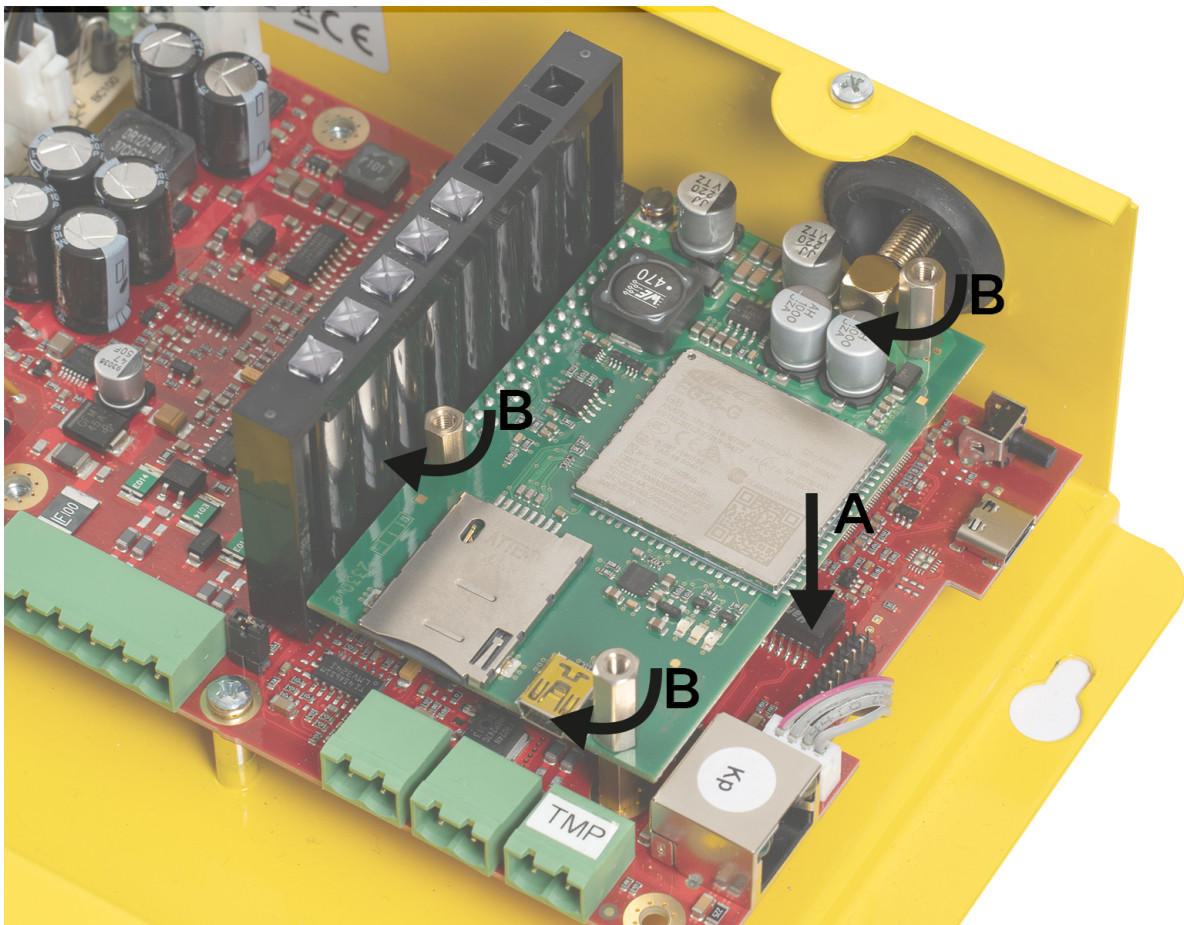

- Now insert the SIM card.

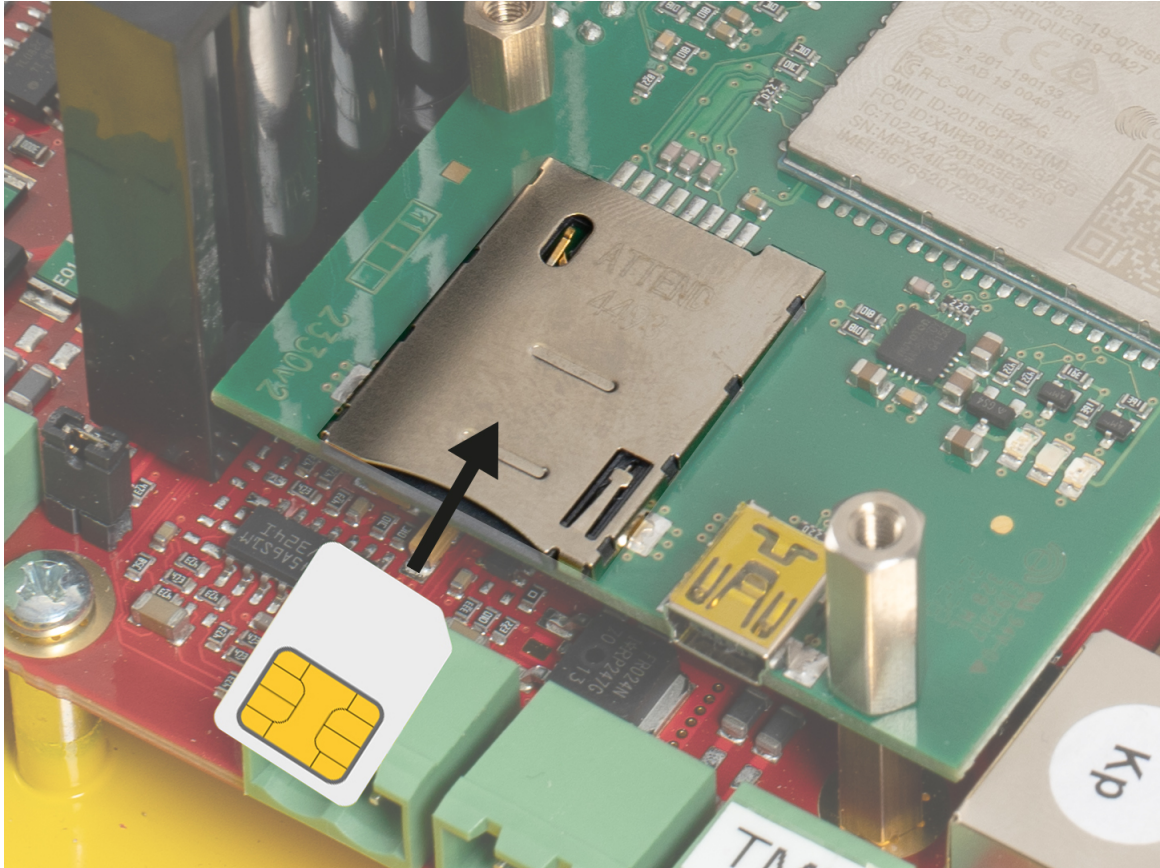

- Connect the antenna.
- Connect the rechargeable batteries. Reconnect the cover – CU bottom connecting grounding wire if disconnected. Replace the cover and tighten the 3 screws.
- Connect the CU to the mains supply.



CAUTION

In places with a poor signal quality find an appropriate place or use a special (directional) antenna.

For parameters 011–016, 021–026, 071–076 and 081–086: If the call is routed to a mobile network (2G, 3G, VoLTE), fill in the phone number (602123456, e.g.). If the call is routed via SIP, enter "sip" before the phone number (sip:602123456, e.g.). At the same time, connect the device to the SIP server.

Signal Strength Levels

LED color	red	yellow	green
Signal level	> -93 dBm	-92 dBm <-> 72 dBm	> -71 dBm

**TIP**

It is possible to force the preferred network type (2G/3G/4G) using parameter 711.

Audio Unit – Fireman

The Fireman audio unit is available in two versions:

Fireman PCB

Description: 1 button

The Fireman audio unit is used for fire fighting operations. Activates the top priority call. The connection is established between the Fireman audio unit, the cabin audio unit and the machine room audio unit in one and the same elevator shaft.

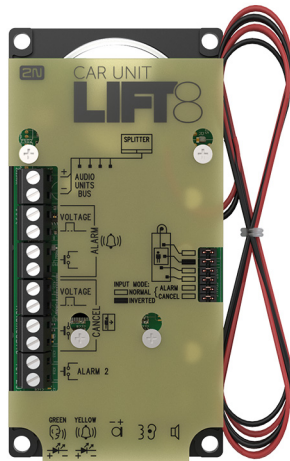

Install the Fireman audio unit in a dedicated space that can be easily accessed by firemen.

The Fireman call has the highest priority, suspending all the other calls (refer to [Function Description \(p. 173\)](#)). It is set up on the cabin audio unit in one and the same shaft.

The Fireman call is made by a button press. The call is hands-free and terminated by pressing the button again. The maximum possible call duration is unlimited.

The Fireman call setup is signaled by the Fireman audio unit LED (mounted on the PCB or carried externally from connector 8).

The Fireman call is indicated by a flashing green LED on the machine room audio unit. The audio unit microphone is off by default. Press and hold the **TRIPHONY** button for 3 seconds to activate the microphone and enable communication within a Fireman call. Once the microphone is activated, the **TRIPHONY** button starts flashing.



WARNINGS

- The Fireman call has the highest priority, suspending all the other calls except for the Fireman call set up in another shaft.
- The Fireman call is set up by the cabin audio unit in one and the same shaft.
- The audio unit is powered from the CU or splitter via a 2-wire bus. Disconnection of the audio unit from the bus results in the audio unit switch-off.
- The button is not included.

Description: 2-Button Version (Push-To-Talk)

The Fireman audio unit is used for fire fighting operations. Activates the top priority call. The connection is established between the Fireman audio unit, the cabin audio unit and the machine room audio unit in one and the same elevator shaft.

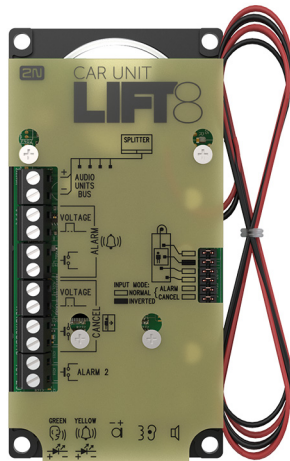

CAUTION – UPGRADE

- The horn is being initialized – the green LED is on and the red LED on the back is on.
- When the audio unit is being upgraded, the green LED flashes, the red LED on the back of the audio unit is permanently on.
- No LED is illuminated upon upgrade and the audio unit is ready for use.

Install the Fireman audio unit in a dedicated space that can be easily accessed by firemen.

The Fireman call has the highest priority, suspending all the other calls (refer to [Function Description \(p. 173\)](#)).

The Fireman call is set up by pressing a lock button. The call is hands-free and terminated by pressing the lock button again. The maximum possible call duration is unlimited.

The Fireman call setup is signaled by the Fireman audio unit LED (mounted on the PCB or carried externally from connector 8).

The two-button version allows you to connect another, Push-to-Talk button. Pressing the Push-to-Talk button mutes all the other audio units connected to the Fireman call and the sound is only transmitted from the Fireman audio unit. When you release the Push-to-Talk button, audio transmission is re-enabled from the other audio units.

The Fireman call is indicated by a flashing green LED on the machine room audio unit. The audio unit microphone is off by default. Press and hold the **TRIPHONY** button for 3 seconds to activate the microphone and enable communication within a Fireman call. Once the microphone is activated, the **TRIPHONY** button starts flashing.



CAUTION

- The Fireman call has the highest priority, suspending all the other calls except for the Fireman call set up in another shaft.
- The Fireman call is set up to the cabin and machine audio units in one and the same shaft.
- The audio unit is powered from the CU or splitter via a 2-wire bus. Disconnection of the audio unit from the bus results in the audio unit switch-off.

Before You Start

Fireman audio unit package contents:

- 1 electronics board
- 3 terminals
- 1 board-mounted jumper (defining the button version)
- 1 speaker connected directly or by cable
- 1 microphone (integrated)
- 1 cover with printing
- 5 cable ties

Installation Conditions

- The panel has to be installation-ready, including speaker perforation.
- There must be free space of at least 65 x 130 x 20 mm behind the panel.

Mounting

Electronics Mounting

Typically, the panel is ready for installation as shown in the drawing below:

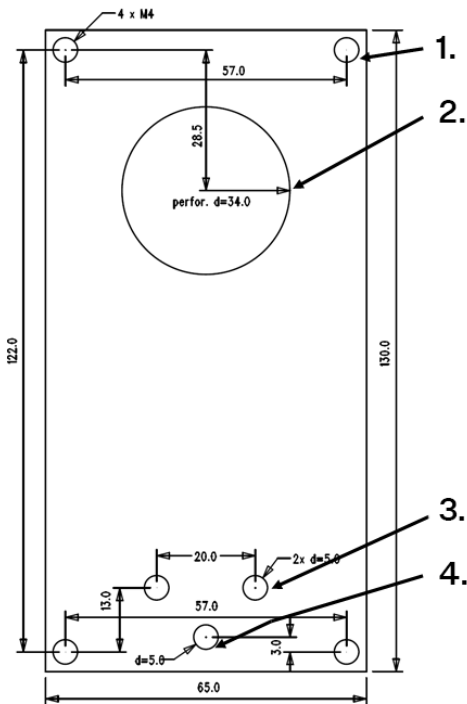

1. M4 threaded weld-on bosses
2. Speaker perforation
3. LED indicator holes (optional)
4. Perforation or microphone hole

Figure: Audio Unit Mounting Hole Dimensions

To mount an audio unit (from the inside of the panel), you need 4 electrically spot welded M3 or M4 screws, a sufficiently perforated speaker area and a microphone hole. In emergency, you can fix the audio unit on a perfectly degreased surface with a high-quality double-sided foam self-adhesive tape.

Requirements

The minimum center-to-center distance between the speaker and the microphone is 90 mm. A shorter distance may lead to acoustic feedback. A greater distance does not matter.

Separate Speaker Mounting

The speaker is equipped with a cable and can be separated from the electronics by simply being slid out within the reach of the cables delivered (1 m). This option is useful where there is not enough space for the whole electronic equipment. Fit the speaker according to the instructions below:

- While gluing the speaker, choose such procedures or adhesives that prevent membrane damage by adhesives and volatile substances or heat.
- We recommend that you keep the speaker sealed to eliminate vibrations and provide electrical insulation.

Frequently Asked Questions about Speaker

May I use a speaker of my own?

Yes, but make sure that the impedance is 64 Ω. By doing this you assume responsibility for sufficient volume and frequency range.

May I use a longer cable to the speaker?

For the speaker yes, but we do not recommend it for the microphone.

Electric Installation

Description of Terminals, Connectors and Jumpers

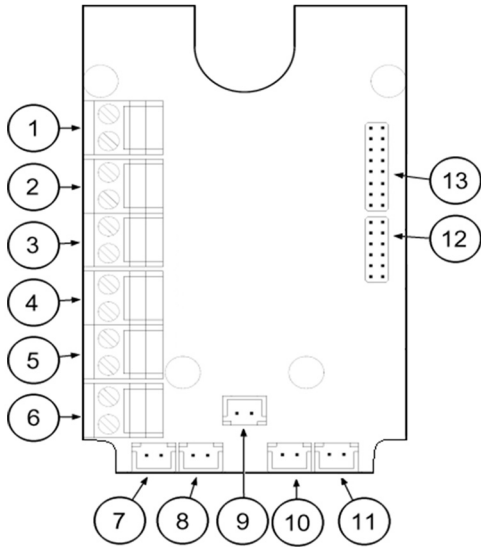
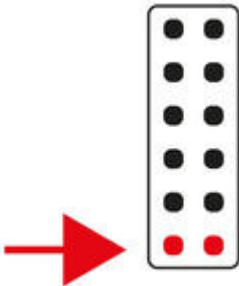

Figure: Terminals, Connectors and Jumpers on Fireman PCB

Terminals		Connectors	
1	Configuration jumpers	7	Disconnected
2	Disconnected	8	LED
3	Disconnected (1-button version) Fireman call activation – with detent (2-button version)	9	Microphone connector (optionally)
4	Disconnected	10	Induction loop connector
5	Activation/Deactivation – without detent (1-button version) Push to Talk – without detent (2-button version)	11	Speaker connector
6	Disconnected	13	Service connector
Configuration jumpers		Two LED signal lamps (other side)	

Terminals	Connectors
<p>12</p> 	<p>1. (yellow) shining – active Fireman call flashing – Push to Talk (for 2-button versions only)</p> <hr/> <p>2. (green)</p>
<p>The lower pin defines the button count</p> <p>jumper connected – 1 button (default)</p> <p>jumper disconnected – 2 button</p>	



WARNING

If an external LED is connected to connector 8, the LED 1 indicator will not be shining.

Bus Connection

Pull the terminal out of the audio unit bus connector 1, connect the audio unit bus wires and replace the terminal to the connector. Mind the polarity.



WARNING

- The audio unit is intended for the **2N Lift8** audio unit bus connection exclusively. Do not connect the audio unit to other wires to avoid its damage or destruction.
- Maintain the polarity while connecting the audio unit to avoid the audio unit error.



CAUTION

- The audio unit is fed via a 2-wire bus. Disconnection of these wires results in the audio unit switch-off.
- The proper polarity (+ -) is shown on the audio unit cover.

Volume Settings

Slightly loosen the four screws and shift the cover downwards. Now you can remove the cover. Use the trimmer located in the bottom part of the electronics to set the required volume level (see the figure below).



CAUTION

Use the trimmer to set the best acoustic properties eliminating feedback.

Fireman

Description: 1 button

The Fireman audio unit is used for fire fighting operations. Activates the top priority call. The connection is established between the Fireman audio unit and the cabin audio unit in one and the same elevator shaft.





CAUTION

- The Fireman audio unit is being initialized – the blue LED around the button is on.
- The blue LEDs flash to indicate audio unit upgrading.
- No LED is illuminated upon upgrade and the audio unit is ready for use.

Install the Fireman audio unit in a dedicated space that can be easily accessed by firemen.

The Fireman call has the highest priority, suspending all the other calls (refer to [Call Queuing \(p. 173\)](#)).

The call is made by a button press. The maximum possible call duration is unlimited.

You can only end the call by pressing the button again.

The Fireman call setup is signaled by the Fireman audio unit LED (blue LED shining around the button).

The Fireman call is indicated by a flashing green LED on the machine room audio unit. The audio unit microphone is off by default. Press and hold the **TRIPHONY** button for 3 seconds to activate the microphone and enable communication within a Fireman call. Once the microphone is activated, the **TRIPHONY** button starts flashing.



CAUTION

- The Fireman call is set up to the cabin and machine audio units in one and the same shaft.
- The Fireman call has the highest priority, suspending all the other calls except for the Fireman call set up in another shaft.
- The audio unit is powered from the CU or splitter via a 2-wire bus. Disconnection of the audio unit from the bus results in the audio unit switch-off.

Description: knob+button (Push to Talk)

The Fireman audio unit is used for fire fighting operations. Activates the top priority call. The connection is established between the Fireman audio unit, the cabin audio unit and the machine room audio unit in one and the same elevator shaft.



CAUTION

- The Fireman audio unit is being initialized – the blue LED around the button is on.
- The blue LEDs flash to indicate audio unit upgrading.
- No LED is illuminated upon upgrade and the audio unit is ready for use.

Install the Fireman audio unit in a dedicated space that can be easily accessed by firemen.

The Fireman call has the highest priority, suspending all the other calls (refer to [Call Queuing \(p. 173\)](#)).

Turn the knob to position 1 (0 > 1) to activate the Fireman call. Turn the knob back to position 0 to terminate the Fireman call. The maximum possible call duration is unlimited.

The Fireman call setup is signaled by the Fireman audio unit LED (blue LED shining around the button).

Pressing the Push to Talk button mutes all the other audio units connected to the Fireman call and the sound is only transmitted from the Fireman audio unit. Release the Push to Talk button to re-enable audio transmission from the other audio units.

The Fireman call is indicated by a flashing green LED on the machine room audio unit. The audio unit microphone is off by default. Press and hold the **TRIPHONY** button for 3 seconds to activate the microphone and enable communication within a Fireman call. Once the microphone is activated, the **TRIPHONY** button starts flashing.



CAUTION

- The Fireman call is set up to the cabin and machine audio units in one and the same shaft.
- The Fireman call has the highest priority, suspending all the other calls except for the Fireman call set up in another shaft.
- The audio unit is powered from the CU or splitter via a 2-wire bus. Disconnection of the audio unit from the bus results in the audio unit switch-off.

Before You Start

Product Completeness Check

Check whether the contents of the package of your new **2N Lift8** Fireman complies with the following list:

1x **2N Lift8** Fireman

1x Torx 10 / Torx 20 double-ended wrench

1x Bushings (enclosed):

- 1x big two-hole sealed bushing with nut
 - 1x spare sealing for big bushing for a thick cable, one hole
 - 1 big blank with nut
 - 1x small bushing with nut
 - 1x bushing plug, big size
 - 2x bushing plugs, small size
-

1x **2N Lift8** Fireman Brief Manual

1x mounting template

4x 5 x 90 mm screw

4x "intelligent" dowel (8 x 50) mm

Electric Installation

Use the Torx 20 spanner included in the delivery to loosen the 4 screws and remove the audio unit front cover. Find the board with electronics under the cover.

Description of Terminals, Connectors and Jumpers

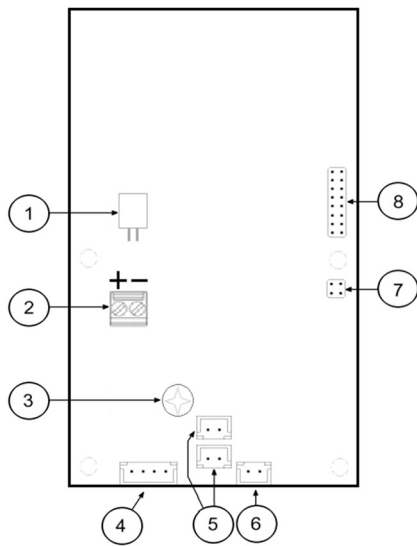

Terminals, Connectors and Jumpers on Fireman Audio Unit Board

Terminals and Connectors			
1	Speaker connector	5	2 microphone connectors
2	Audio unit bus	6	Detent button (knob) connector
3	Volume setting	7	Configuration jumper
4	Button connector (Push to Talk)	8	Service connector

Bus connection

Remove the audio unit cover and unplug terminal 2 (audio unit bus). Connect the bus and replace the terminal. Mind the polarity.



WARNING

- The audio unit is intended for the **2N Lift8** audio unit bus connection exclusively. Do not connect the audio unit to other wires to avoid its damage or destruction.
- Maintain the polarity while connecting the audio unit to avoid the audio unit error.



CAUTION

The audio unit is fed via a 2-wire bus. Disconnection of these wires results in the audio unit switch-off.

Wiring 2 Fireman Audio Units

In L8 firmware version L8 2.9.0. and higher, it is possible to connect up to 2 Fireman audio units to one splitter. Different addressing has to be set for each of the 2 Fireman audio units connected. Fireman is addressed by mounting a jumper on the top pair of pins for configuration jumpers 7.

Table of configuration jumper mounting options:

	Fireman 1	Fireman 2
Knob+Button	<p>1 <input type="checkbox"/></p> <p>0 <input type="checkbox"/></p>	<p>1 <input checked="" type="checkbox"/></p> <p>0 <input type="checkbox"/></p>

Volume Settings

Use the trimmer on the electronics board to adjust the volume (refer to the Description of Terminals, Connectors and Jumpers).



CAUTION

Use the trimmer to set the best acoustic properties eliminating feedback.

Mounting Completion

1. Having connected all the wires, check the bushings if employed for tightness.
2. Replace the front cover carefully. Make sure that the wires inside the device are placed so that there is space for the front panel. Tighten the four screws thoroughly to push the panel by about 1 mm to fit tightly to the metal chassis. You can use the wrench included in package for tightening (Torx 20).



CAUTION

- Improper mounting may deteriorate the Fireman waterproofness. Water infiltration may damage the electronic part.
- Stainless steel screws are used for the **2N Lift8** Fireman assembly. Other screws than stainless steel ones corrode soon and may aesthetically deteriorate the screw area!

Fireman – Mechanical Mounting

Mechanical Mounting – Mounting Types

See below for the mounting types and necessary components.

Surface mounting

- (for concrete and steel structures, etc.)

What you need for mounting:

- 2N Lift8 Fireman only (no need for covering frame)

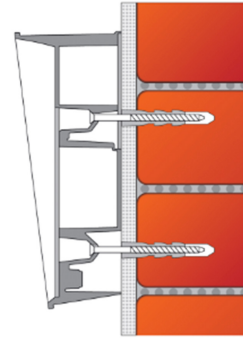

Flush mounting – classic bricks

What you need for mounting:

- Properly cut-out hole or, optional Part No. 9151001
- For 2N Lift8 Fireman: Covering frame: Covering frame



Flush mounting – thermally insulated wall

What you need for mounting:

- The brick flush mounting kit, Part No. 9151001
- For 2N Lift8 Fireman: Covering frame: contact your distributor

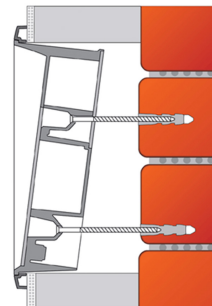

Flush mounting – hollow bricks

What you need for mounting:

- The brick flush mounting kit, Part No. 9151001
- For 2N Lift8 Fireman: Covering frame: contact your distributor

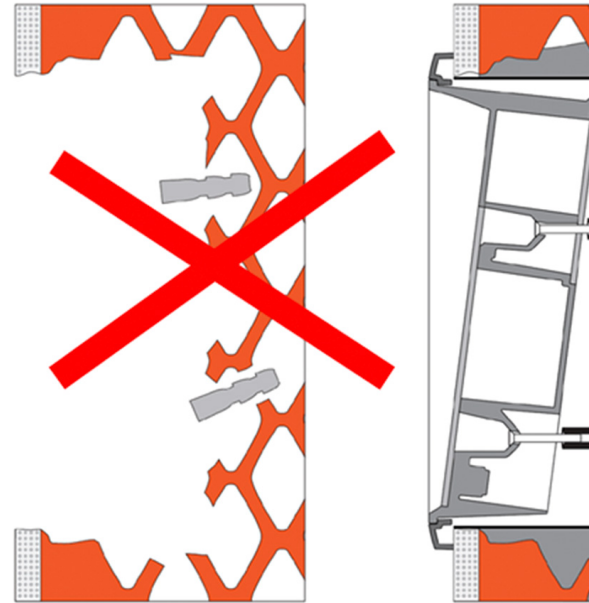

Flush mounting – plasterboard

What you need for mounting:

- Use the plasterboard flush mounting box (Part No. 9151002).
- For 2N Lift8 Fireman: Covering frame: contact your distributor

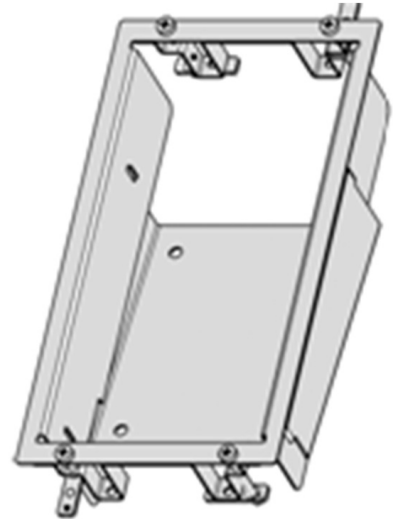



CAUTION

- The warranty does not apply to the product defects and failures arisen as a result of improper mounting (in contradiction herewith).
- When the proper mounting instructions are not met, water might get in and destroy the electronics. The circuits are constantly under voltage and water leakage causes electro-chemical reaction. The manufacturer's warranty shall be void for products damaged in this way!

General Mounting Principles



TIP

- Select flush mounting where possible. It makes the product more elegant looking, more vandal resistant and more secure.
- You can purchase the flush mounting box in advance and hire an installation professional to make the basic installation work. Moreover, the flush mounting kit helps you level the audio unit properly (with a maximum vertical position deviation of 2°).



CAUTION

- Make sure that the diameters of the dowel holes are accurate. If the diameters are too large, the dowels may get loose. Use the mounting glue to secure the dowels if necessary.
- Make sure that the depths of the dowel holes are accurate! The dowels are 50 mm long and the screws are 90 mm long.
- Do not use low-quality dowels to avoid their falling out of the wall!
- Stainless steel screws are used for the **2N Lift8 Fireman** assembly. Other screws than stainless steel ones corrode soon and may aesthetically deteriorate the screw area!
- Make sure that no dirt can get inside (onto the sealing surface and microphone sound guides in particular) while removing the front panel.



NOTE

The microphone sound guides are normally loose after the front panel is removed! The screw is only used as a fall-out protection during installation.

Surface mounting

Wall (surface) mounting is used wherever flush mounting is not applicable – in concrete and steel structures, for example. The frame is not used.



WARNING

Eliminate the risk of personal injury! Wall mounting is not recommended for narrow passages or places where people's attention is distracted by something else. The manufacturer shall not be liable for injuries in such cases!



CAUTION

- Wall mounting is a problem where the device may be damaged by vandals. Therefore, use steel fixing elements instead of the dowels and screws included in the delivery.
- Be sure to insert plugs in unused bushing holes! It is because water may splash in during facade cleaning, for example. Never leave the holes open for even a short time (one day delay between mounting and cable connection, e.g.).

1. Choose the audio unit position according to the supply cables too. If the cables lead inside a structure or wall, use the holes on the audio unit bottom.
2. Drill plug holes of the depth of 70 mm (as shown in the figure below) into concrete and similar walls. Push or hammer the enclosed dowels into the drilled holes. Use some suitable building adhesive if the dowels are too loose. Use fixing elements of your own for steel structure surface mounting (metric screws + nuts, e.g.).
3. Remove the front panel from the audio unit.
4. Select the holes for the cables. Select and mount the bushings depending on the cables: 2-hole bushing or 1-hole bushing or both. Insert the included blanks in the other holes.
5. Attach the audio unit to the wall/structure and introduce the cables inside. Leave some of the cables inside as a reserve. Insert the plugs in the unused bushings and tighten the bushing nuts carefully.
6. Do not complete the mounting procedure until you have connected the audio unit electrically – refer to Electric Installation. Where cables lead along the surface, use the bushings included in the delivery.

Flush mounting – classic bricks

Follow the instructions for the flush mounting kit if used. Follow the instructions below if you do not use the flush mounting kit.

1. Make a hole using the template. It is assumed that all the required cables have been carried into the hole. Be careful while drilling the dowel holes! This type of mounting does not allow you to balance rather great deviations!
2. Unpack the frame, put the audio unit onto it to test whether the hole is deep enough and its uneven edge is completely covered by the frame.
3. Push or hammer the enclosed dowels into the drilled holes. Use some suitable mounting adhesive if the dowels are too loose.
4. Remove the front panel from the audio unit.
5. Select the holes for the cables. Insert the included blanks in the other holes. Apply the cable bushings or a suitable sealant to prevent penetration of insects or water. You can also insert the small bushing in the audio unit bottom hole.
6. Put the frame on the audio unit.
7. Insert the audio unit in the hole and put the cables in at the same time. Keep the excessive cables under the audio unit bottom leaving a small cable reserve inside.
8. Insert the screw in the dowels in the holes on both the audio unit sides. Tighten all the screws carefully. Caution: the screw tightening sequence may affect the audio unit position.
9. Seal the frame against the wall with some silicon or other cement, yet this is unnecessary for the audio unit function. The sealing helps protect the wall against dampening due to water leakage.
10. Do not complete the mounting procedure until you have connected the audio unit electrically – refer to Electric Installation.

Flush mounting – thermally insulated wall

Cut out the thermal insulation layer using the template (the same as for classic brick wall).



CAUTION

- The hole depth depends on the insulation layer thickness. If the insulation layer is rather thick, you may need longer screws! If there are hollow bricks under the insulation, make sure that your screws pass through the whole dowel (50 mm)! Otherwise, the dowel does not hold in a hollow brick.
- Make sure that the diameters of the dowel holes are accurate. If the diameters are too large, the dowels may get loose. Use the mounting glue to secure the dowels if necessary.
- Make sure that the depths of the dowel holes are accurate! The dowels are 50 mm long and the screws are 90 mm long.

It is assumed that all the required cables have been carried into the hole. Now follow the instructions applicable for classic brick flush mounting. However, remember that thermally insulated walls show less strength than classic brick walls.

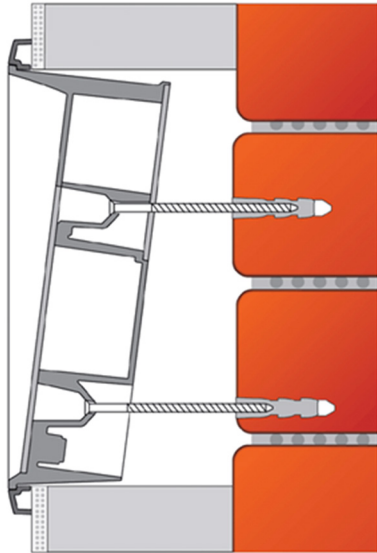

Flush mounting – hollow bricks

Note that the external side of the hollow bricks gets damaged by cutting and the dowels cannot practically be fixed into the thin internal part of the bricks. Therefore, use the brick flush mounting kit and follow the instructions included therein.

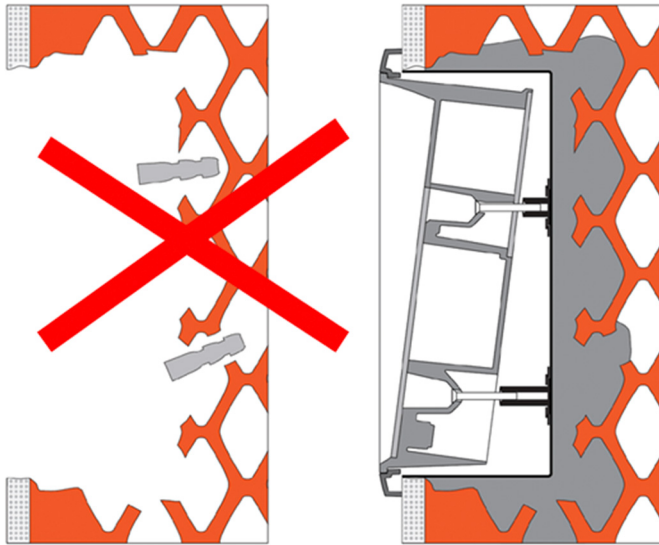

Flush mounting – plasterboard

Use the plasterboard flush mounting box and follow the instructions included therein.

MEEF Evacuation Audio Unit – Cabin Connection

The evacuation audio unit for the MEEF (Main Elevator Evacuation Floor) is used for connection with the elevator cabin in the Evacuation mode. Activates the top priority call. The connection is established between the evacuation audio unit, the cabin audio unit or the machine room (if installed) in the same elevator shaft. If any of the machine room audio units is set as a control room (intercom), it is possible to join the evacuation call.

Only one of these audio units can be connected to one splitter.





Description of Use

Install the audio unit in a pre-designated space where the audio unit is easily accessible. The evacuation call has the highest priority, suspending all the other calls. It is set up on the cabin audio unit in one and the same shaft.

The call is made by a button press. The call is hands-free and terminated by pressing the button again. The maximum call duration is not limited.

The call setup is signaled by a LED on the panel front.

If the control-room configured machine room audio unit is used, the Fireman call is signaled by a green LED flashing on the audio unit. Press  (for more than 2 s) on the audio unit keypad to join in the call. Press  (for more than 2 s) on the audio unit keypad to leave the call without terminating it.



CAUTION

- The call has the highest priority, suspending all the other calls.
- The call is set up by the cabin audio unit in one and the same shaft.
- The audio unit is powered from the CU or splitter via a 2-wire bus. Disconnection of the audio unit from the bus results in the audio unit switch-off.
- The button is part of the front panel.

Mechanical Installation

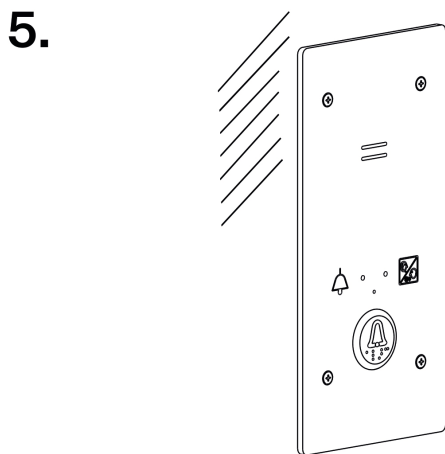
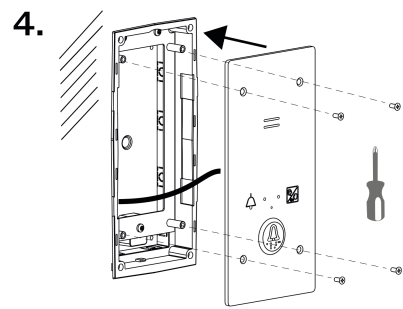
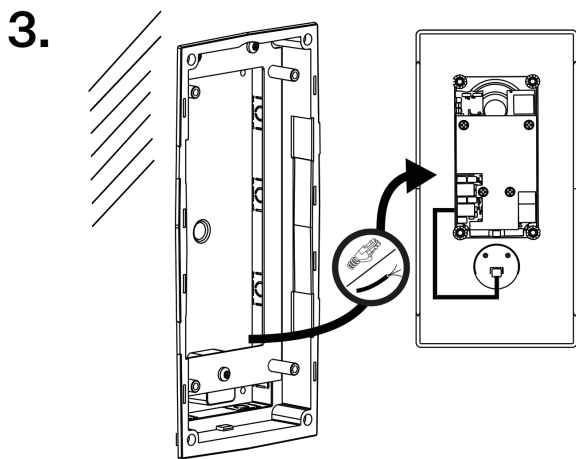
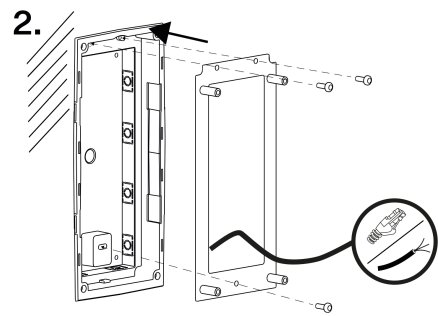
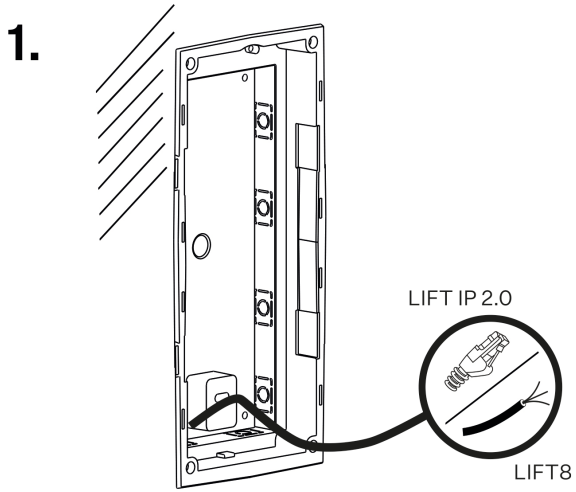

Separate Speaker Mounting

The speaker is equipped with a cable and can be separated from the electronics by simply being slid out within the reach of the cables delivered (1 m). This option is useful where there is not enough space for the whole electronic equipment. Fit the speaker according to the instructions below:

- While gluing the speaker, choose such procedures or adhesives that prevent membrane damage by adhesives and volatile substances or heat.
- We recommend that you keep the speaker sealed to eliminate vibrations and provide electrical insulation.
- The minimum center-to-center distance between the speaker and the microphone is 90 mm. A shorter distance may lead to acoustic feedback. A greater distance does not matter.

Frequently Asked Questions about Speaker

- May I use a speaker of my own?

Yes, but make sure that the impedance is 64 Ω . By doing this you assume responsibility for sufficient volume and frequency range.

- May I use a longer cable to the speaker?

For the speaker yes, but we do not recommend it for the microphone.

Electric Installation

Description of Terminals, Connectors and Jumpers

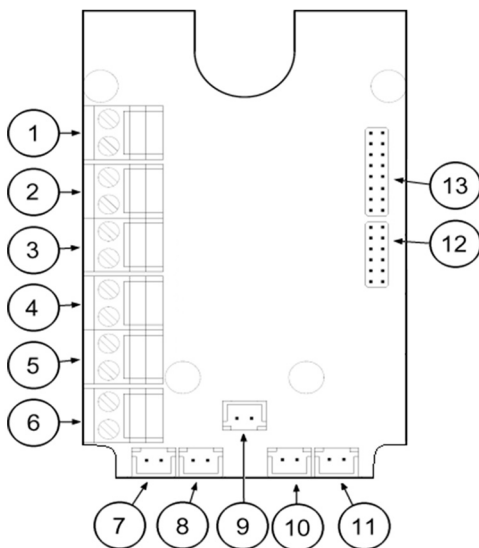

Figure: Board Terminals, Connectors and Jumpers

Terminals		Connectors	
1	Audio unit bus	7	Disconnected
2	Disconnected	8	External LED (optional)
3	Disconnected	9	Microphone connector (optionally)

Description and Installation

Terminals		Connectors	
4	Disconnected	10	Induction loop connector
5	Activation/Deactivation – without detent	11	Speaker connector
6	Disconnected	13	Service connector
Configuration jumpers		Two LED signal lamps (other side)	
12	Jumper connected	1. (yellow)	Lit – call active
	Unused pins	2. (green)	



NOTE

If an external LED is connected to connector 8, the LED 1 indicator will not be shining.

Bus connection

Pull the terminal out of the audio unit bus connector 1, connect the audio unit bus wires and replace the terminal to the connector. Mind the polarity.

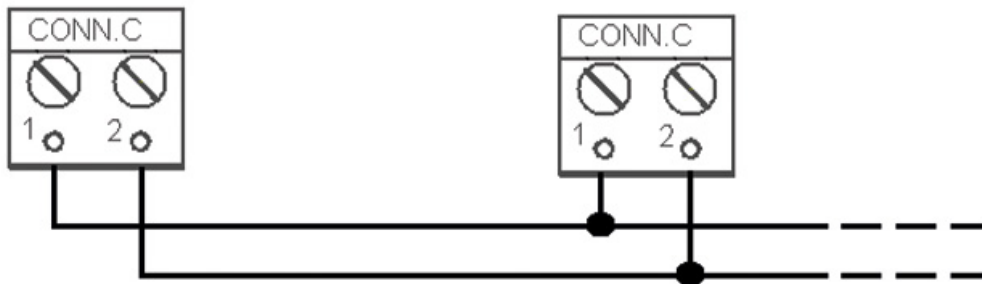

1. Audio unit bus +
2. Audio unit bus -



WARNING

The audio unit is intended for the 2N Lift8 audio unit bus connection exclusively. Do not connect the audio unit to other wires to avoid its damage or destruction.



CAUTION

- Maintain the polarity while connecting the audio unit to avoid the audio unit error. The proper polarity (+ -) is shown on the audio unit cover.
- The audio unit is fed via a 2-wire bus. Disconnection of these wires results in the audio unit switch-off.

Volume Settings

Slightly loosen the four screws and shift the cover downwards. Now you can remove the cover. Use the trimmer located in the bottom part of the electronics to set the required volume level (see the figure below).



CAUTION

Use the trimmer to set the best acoustic properties eliminating feedback.

Evacuation Audio Unit – Evacuation of Floors

Description

2N Lift8 Audio Unit, Landing (Evac.) (Part No. 918618EE) is an audio unit designed for installation at the evacuation elevator on the floors. The audio units provide connection with the control room for evacuation coordination.

Press the button (for more than 3 seconds) to set up a call to the control room. Once the call is received by the control room, the connection is established. The call is hands-free and cannot be terminated from the audio unit.

The call setup is signaled by the Fireman audio unit LED.

Mechanical Installation

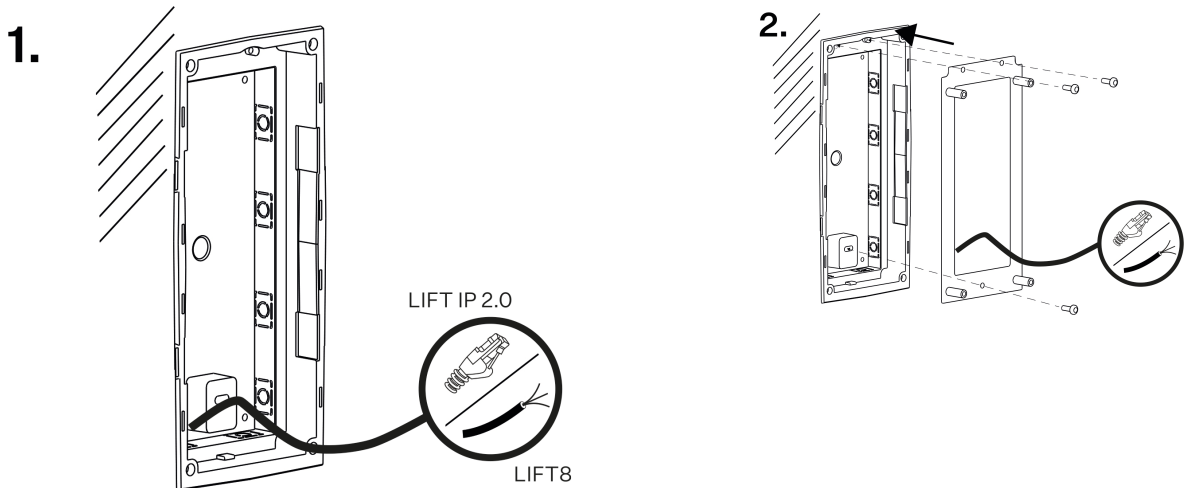

Description and Installation

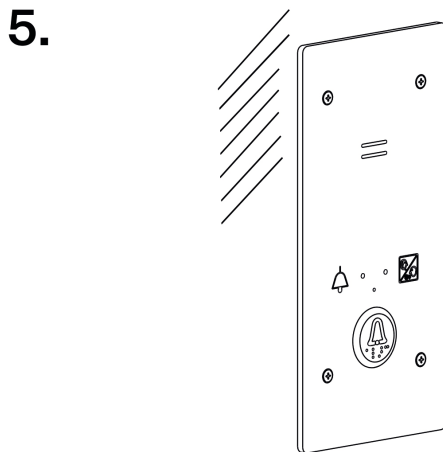
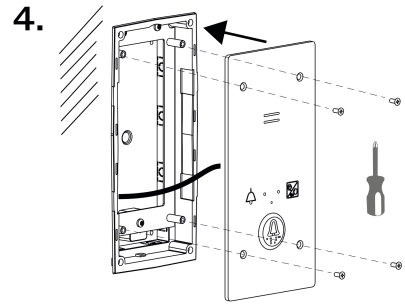
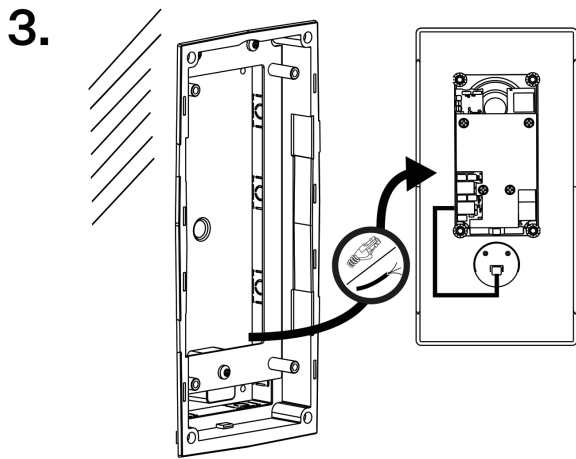

Electric Installation

Description of Terminals, Connectors and Jumpers

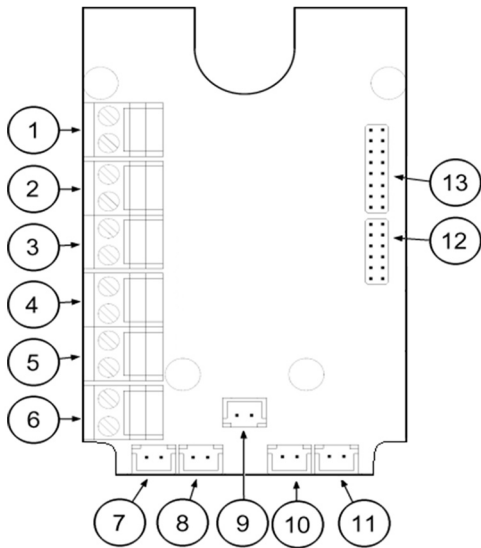

Terminals		Connectors	
1	Audio Unit Bus	7	Green LED Connection established
2	Disconnected (external button, voltage activation)	8	Yellow LED Active call
3	Disconnected (external button, contact activation)	9	Disconnected (external microphone connector)
4	Disconnected	10	Induction loop connector
5	Disconnected	11	Speaker connector
6	Disconnected	13	Servicing connector
Configuration jumpers		Two LED indicators (other side)	
12	Addressing audio unit	Green	Connection confirmed
		Yellow	Active call

Description and Installation

1. Pull the terminal out of the audio unit bus connector 1.
2. Connect the audio unit bus wires.
3. Replace the terminal to connector. Observe the polarity. The proper polarity (+ -) is shown on the audio unit cover.



WARNING

The audio unit is intended for the **2N Lift8** audio unit bus connection exclusively. Do not connect the audio unit to other wires to avoid its damage or destruction.



CAUTION

The audio unit is powered via a 2-wire bus. Disconnection of these wires results in the audio unit switch-off.

The audio unit addressing is crucial for a proper system functioning. Up to 8 audio units can be connected to one splitter. Each audio unit must be addressed to a unique position within the splitter.

Procedure

1. Reconfigure the jumper on configuration jumper 12.
2. The first 4 pins serve for setting the location of the audio unit.
3. If there is poor access to the pins, you can remove the electronics cover.
 - a. Slightly loosen the four screws and slide the back cover upwards.
 - b. Now you can remove the back cover.
4. Set the audio unit position by placing the jumper according to the following table:

1st position	2nd position	3rd position	4th position	5th position	6th position	7th position	8th position

5. If you have removed the cover, put it back in the original position and tighten the screw.

Within the entire system, the audio units are numbered by individual splitters as follows:

	Splitter 1 (CU)	Splitter 2	Splitter 3	Splitter 4	Splitter 5	Splitter 6	Splitter 7	Splitter 8
1st– 8th posi- tion	1–8	9–16	17–24	25–32	33–40	41–48	49–56	57–64

Volume Settings

Slightly loosen the four screws and shift the cover downwards. Now you can remove the cover. Use the trimmer located in the bottom part of the electronics to set the required volume level (see the figure below).



2N IP Phone D7A

Description

The 2N IP Phone D7A provides a two-way communication with the persons at the audio units. During evacuation, the phone is operated by a responsible and well-trained person, which communicates with the persons on the evacuation elevator floors via an IP phone. External IP cameras can be connected to the phone and show the camera previews on an integrated 7" display.



NOTE

Ensuring reliability and full functionality of the system requires direct peer-to-peer interconnection of the IP phone and the **2N Lift8** Central Unit.



Wiring



NOTE

Ensuring reliability and full functionality of the system requires direct peer-to-peer interconnection of the IP phone and the **2N Lift8** Central Unit.

1. Interconnect the IP phone and the **2N Lift8** Central Unit using an Ethernet cable.
2. Connect the power supply adapter (5 V, 2 A) to the DC5V slot on the phone back.



WARNING

Never use the power supply and PoE supply simultaneously! This may damage the device!

3. The IP phone initialization will be performed automatically.
4. If there is a DHCP server in the network, the phone will obtain the IP address from the server automatically.
5. If no DHCP server is present or active, set the static IP address on the phone as follows:
 - Go to the phone menu: Settings > Advanced settings (password protected) > Network > WAN port > IPv4.
 - Having entered the IP address, subnet mask, default gateway DNS server, press OK in the right-hand upper corner for confirmation.
6. Perform the other basic IP phone settings via the web configuration interface.



NOTE

Refer to the [Evacuation Mode \(p. 195\)](#) section for the IP phone settings in the **2N Lift8** system in the Evacuation mode.

I/O module

Description

The purpose of the I/O Module is to interconnect the Central Unit with the elevator signaling. It is designed for usage of binary inputs or switching of relay inputs. It is connected to the CU via 6 wires (power, audio, data). The inputs/outputs are connected to the I/O Module via 2-pin slide-on terminals.

The I/O Module detects status changes on 4 galvanically isolated logical inputs. Their nominal voltage ranges between 12 and 24V AC/DC. Refer to the table below for the minimum and maximum voltage values. The module also contains 4 output NO contacts equipped with bistable relays. Refer to the table below for the maximum closing values. There may be up to 8 I/O Modules (depending on the count of elevator shafts available).

Remember to set a different address (elevator shaft number) for each I/O Module to make the system work properly. A collision of addresses is signaled by the ERR LED. Set the address manually using the rotary switch in position 1–8 (elevator shaft 1–8). Addresses 9 and 0 are not used. If you set one of them, the ERR LED will indicate an error.

Description and Installation

The I/O Modules are connected serially (in line). Do not use parallel connection. The Lift8 system would be unstable. Connect the terminating resistor connecting jumper to the last device (Splitter or I/O Module furthest from the CU). See the figures below for terminal layout details.

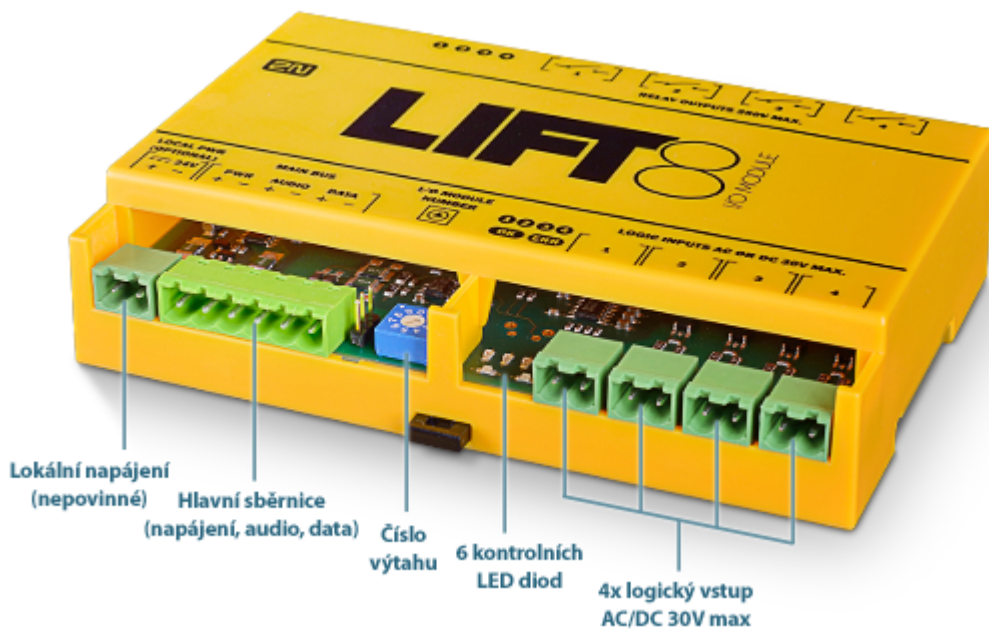

I/O Module – Lower Side

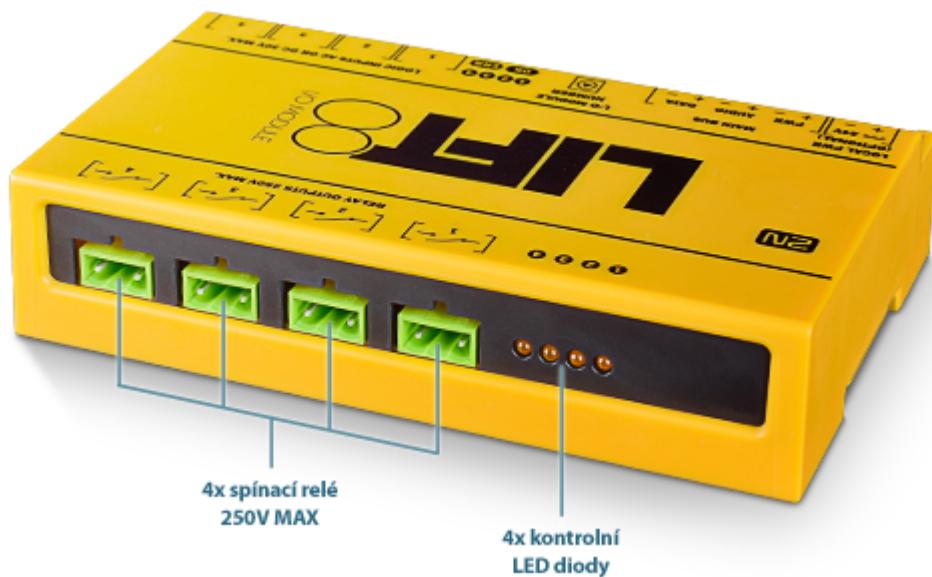

I/O Module – Upper Side

Electronic Installation



CAUTION

- Local power supply is not supported yet. Do not connect any local power supply.
- The main bus power is sufficient for the I/O Module.



CAUTION

During the upgrade of the I/O module, the green LED (OK) flashes rapidly and the red LED (ERR) flashes slowly.

Main Bus Connection

Take the 6-pole main bus connector from the package and connect 6 wires from the CU. The polarity must be maintained (power + –, audio + –, data + –), see the print on the I/O Module cover. Connect the devices serially (in line). Parallel connection is not allowed. Refer to the CU section for more details.

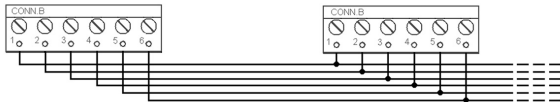

1. Main bus power +
2. Main bus power –
3. Main bus audio +
4. Main bus audio –
5. Main bus data +
6. Main bus data –



WARNING

Maintain the connection polarity. Otherwise, the 2N Lift8 system will not work properly.



WARNING

The bus is electrically isolated from the telephone line circuits according to the EN60950 standard requirements and its low voltage cannot cause any electrical accident.

Terminating Resistor



CAUTION

- A 3-pin termination resistor setting jumper is located between the main bus connection and the elevator number setting.
- Connect the jumper to the first and last device (CU, splitter or I/O module) on the bus. Refer to the Central Unit subsection for more information on mounting the termination resistors.
- The jumper on the splitter on the terminating resistor is factory set to OFF.

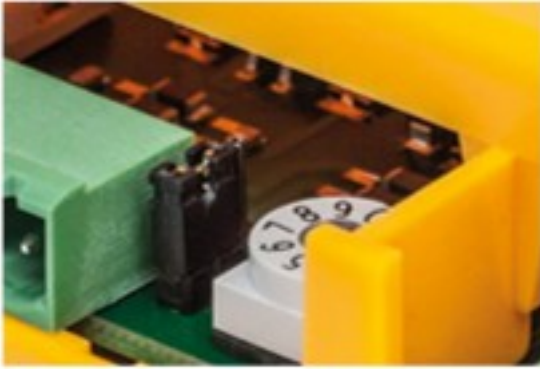

Terminating Resistor OFF



Termination Resistance ON



Terminating Resistor OFF

Address Setting

Use a 10-pin rotary switch 0–9 (see the figure above) to set the I/O Module address for an elevator. Set 1–8 like the shaft number for the splitter (set 5 for elevator 5, e.g.).



WARNING

Do not set address 0 and 9 to avoid system error.

LED Indicators

The I/O Module is equipped with ten LED indicators: Two I/O Module status signaling LEDs, four input status signaling LEDs and four output status signaling LEDs. Refer to the table for details.

Name	Color	Description
OK	Green	If everything is OK, the power supply and bus are connected, the I/O Module communicates with the CU, the LED flashes.
ERR	Red	If the red LED is on, the bus is disconnected or an address is set that conflicts with another I/O Module connected in the system.

Name	Color	Description
Logic Input 1–4	Orange	This LED is on when the given input is active. This means that the appropriate nominal voltage is detected on it to detect logic 1.
Logic Output 1–4	Orange	This LED is on when the given input is active. This means that the given relay is closed.

Logic Input Connection

Up to 4 galvanically isolated logic inputs can be connected to each I/O Module. The nominal voltage of these inputs is 12–24 V. The minimum detectable level is 8 V and the maximum level may not exceed 30 V. Otherwise, the I/O Module input circuits will get damaged. Transition to state 1 occurs with the logic signal rising edge and transition to state 0 with the falling edge. Every transition is detected and displayed in the 2N Service Tool application. At the same time, every status change is recorded in the system log for later use and the user is informed via a pop-up window. See the figure below for an example of input circuit connection.

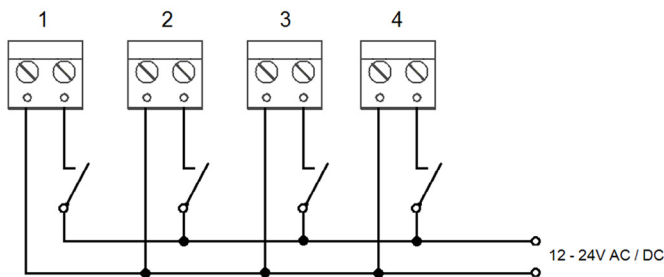

Example of Input Circuit Connection

Output Relay Connection

Every I/O Module is equipped with 4 bistable relays. Their maximum load is 250 V / 5 A per contact. Never exceed this limit to avoid system damage. Failure to do so may damage the equipment. When the relay is closed, the respective LED signals this state. You can configure the relay function in the 2N Service Tool application.

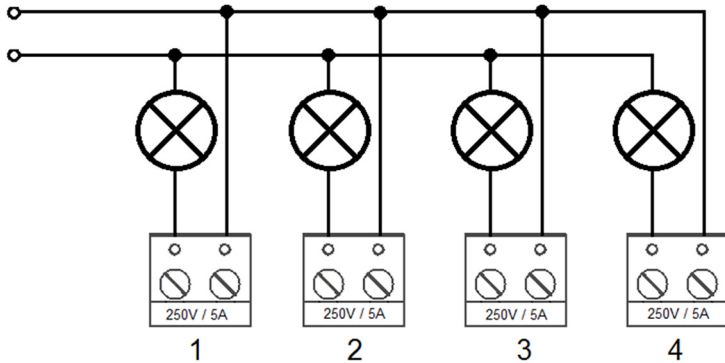

Example of Output Relay Connection



WARNING

- Do not exceed the voltage and current limits for the load connected to the relay contacts as specified in the technical parameters of the device to avoid device damage.
- Never connect any important structural devices such as brakes, door locks, security equipment, etc. to the relay outputs. The I/O Module is not designed and must not be used for such installations. Connect only the devices that will not be damaged by unexpected relay contact disconnection (CU remote upgrade, bus restart, etc.). Unimportant signaling lamps, ventilators, shaft lights, etc. can be connected to the contacts.
- The manufacturer shall not be held liable for damage incurred as a result of improper installations on the relay contact.

Mounting Types Overview

See below for the mounting types and necessary components. Make sure that the installation site is not exposed to flowing or condensed water.



CAUTION

- The warranty does not apply to the product defects and failures arisen as a result of improper mounting (in contradiction with these instructions).
- If the proper mounting instructions are not met, water might get in and destroy the electronics. The splitter circuits are constantly under voltage and water infiltration causes an electro-chemical reaction. The manufacturer's warranty shall be void for products damaged in this way!

Wall mounting

Use the proper wall mounting screws and dowels (not included in the delivery). Hang the device on the wall using the cover bottom holes.

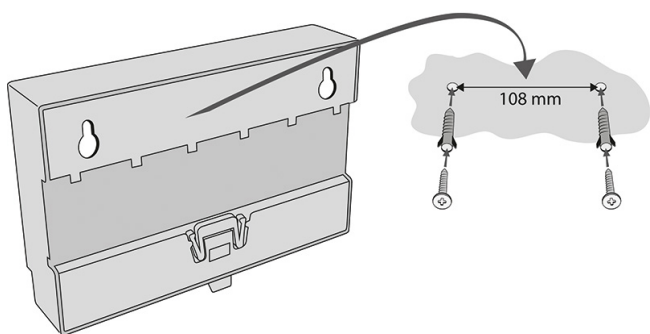

Wall mounting

DIN rail mounting

Mount the device to a standard TS 35 DIN rail. The recommended minimum DIN rail length is 14 cm.

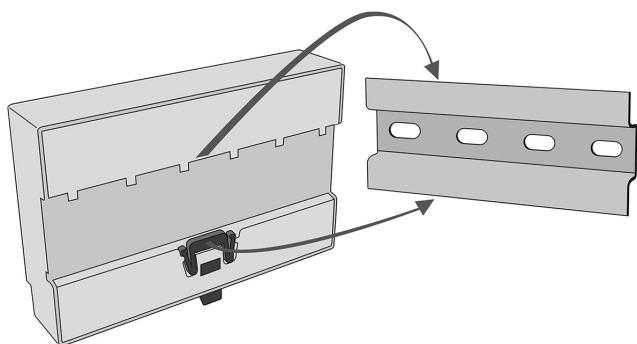

DIN rail mounting

RS232 Module

Description

The RS232 module helps you receive AT commands from the elevator control unit. Some AT commands are supported only. Use the 2N Service Tool to set the transmission rate (115200 by default).

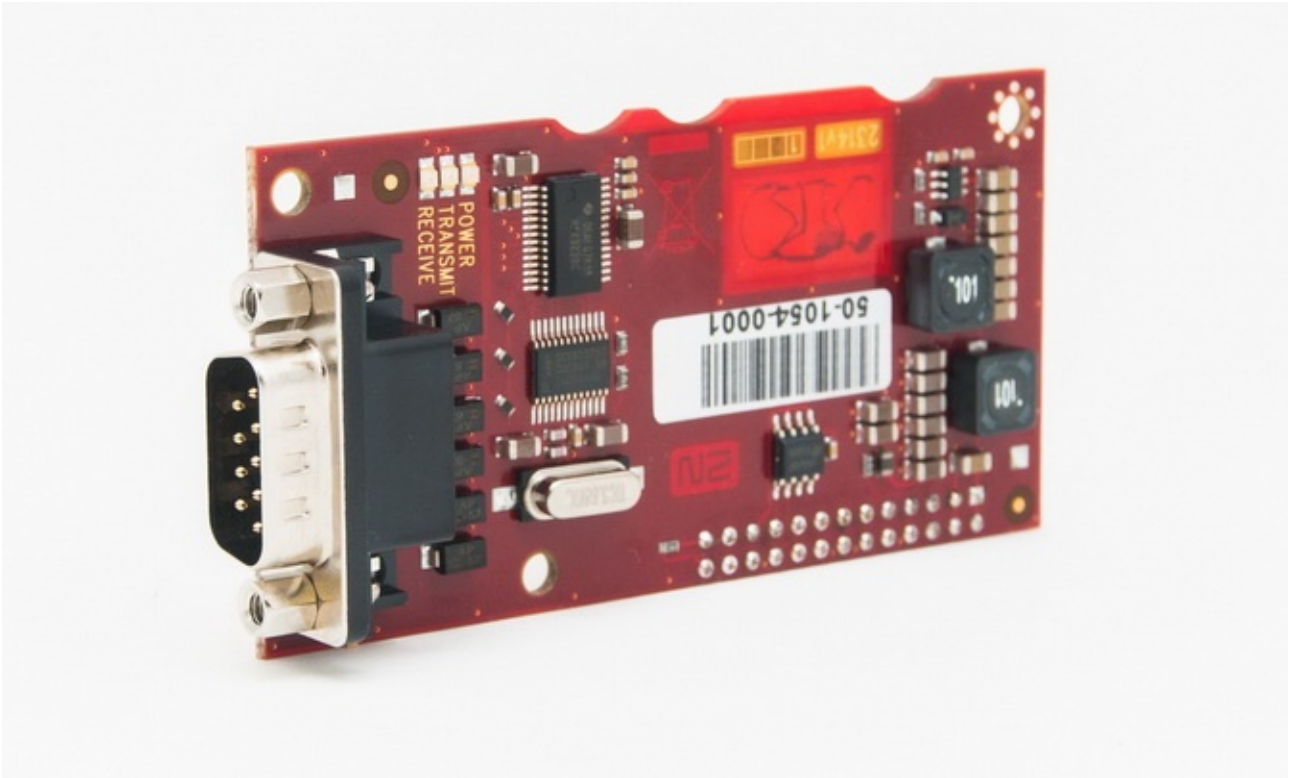

Before You Start

Product Completeness Check

Check the product for completeness before installation.

The RS232 module package contains:

1x electronics board (RS232 module)

2x long threaded spacers

1x short screw spacer

1x screw

1x RS232 cable

1x cable bushing

Description of Connection

1. Keep the CU disconnected from the mains.
2. Loosen the three screws on the upper cover of the CU.
3. Move the upper cover of the CU in such a way that you can remove it.
4. Proceed with caution while removing the cover, be careful about the grounding wire connecting the cover with the CU bottom part. Do not disconnect the wire unless necessary!

5. Disconnect the back-up rechargeable batteries if available using the battery - CU cable FASTON terminals.
6. Unscrew 2 screws (1) and replace them with 2 threaded spacers. Fit the screw spacer (2) into the LED plastic cover (see Fig.).



TIP

To make your spacer mounting easier, turn the screw until it stops and use a cross-point screwdriver to fit the spacer. Having tightened the spacer in the LED plastic cover, use flat-nose pliers to secure the spacer against spinning and remove the screw.

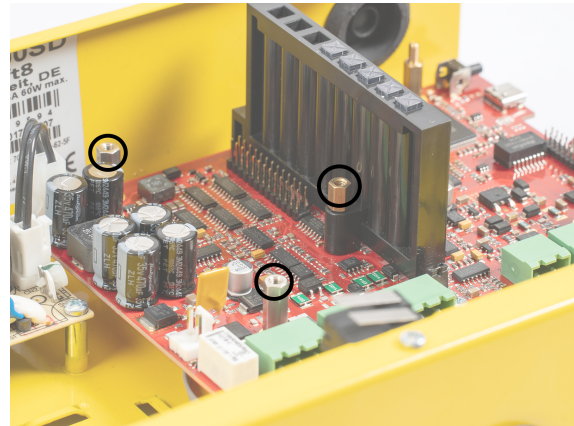
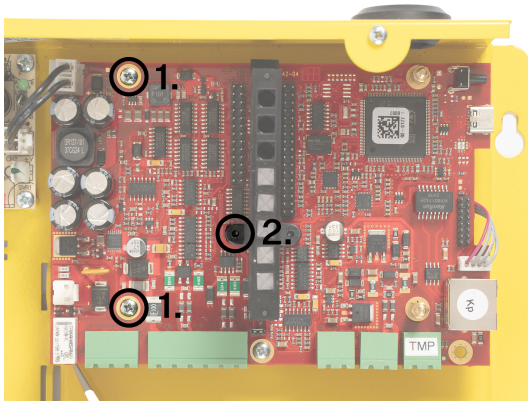

7. Now mount the RS232 module. Be careful while putting the module on the pins. Make sure that you have connected all the pins to the module connector.

8. Having fitted the pins into the connector correctly, you can fix the module using 3 screws (see Fig.).

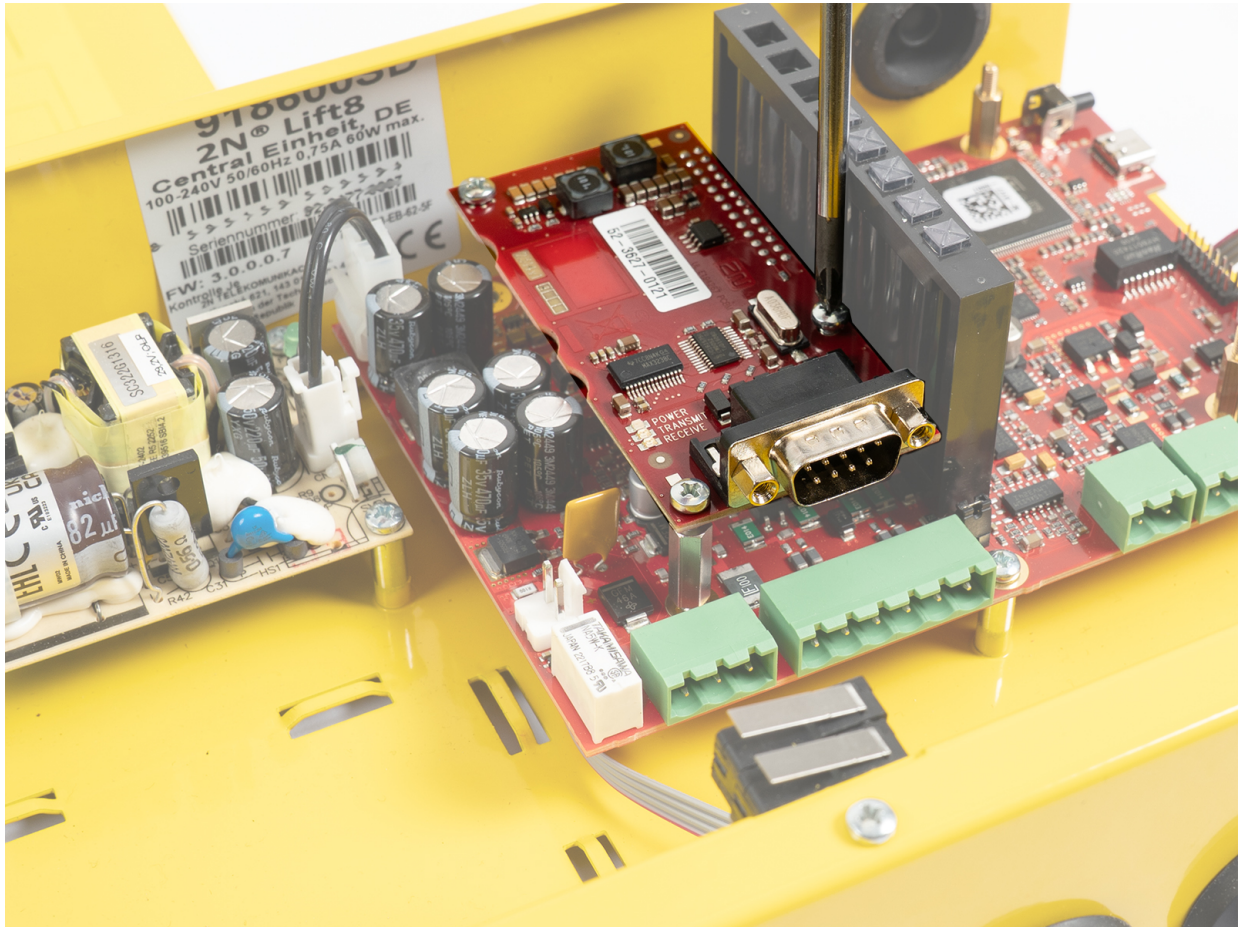

9. To mount the RS232 cable, remove the blank module on the CU bottom edge. Put a cable bushing on the RS232 cable and insert it in the empty space (the cable bushing is factory-cut in one point for easier handling).
10. Connect the rechargeable batteries and replace the CU cover. Tighten the 3 screws to fit the cover.

Supported AT Commands

AT Command	Example	AT Command Info	Note
AT+CMGS=	AT+CMGS="603123456",145<CR>sms text<Ctrl+z> or without apostrophes AT+CMGS=603123456,145<CR>sms text<Ctrl+z>	Send SMS	<CR> = Enter 145 – international number (including +) 129 – national number
AT+CMGF=	AT+CMGF=1	Select SMS mode	

AT Command	Example	AT Command Info	Note
ATE1	ATE1	Enable echo	Returns typed characters to the terminal
ATE0	ATE0	Disable echo	
ATE	ATE	See ATE0	
AT	AT	Start command row	

See [here](#) for details on AT commands.

Serial Port Configuration

You can only set the transmission rate of 9600–115200 bauds for the serial port.

The other parameters are preset:

Bits per word	8 bits
Parity	no parity
Stop bits	1 stop bit

System Configuration

The system is supplied pre-configured.

This section describes the **2N Lift8** configuration.

2N Lift8 Programming

The advantage of the **2N Lift8** system is that only the CU is programmed where all the parameters are stored. Hence, you do not have to reconfigure anything to replace an audio unit. You can program just one CU for multiple elevator systems. The memory is independent of the CU power.

2N Lift8 can be programmed in the following ways:

1. Using the Service Tool (USB connection or IP address), see [Service Tool \(p. 203\)](#).
2. Via a long distance phone call (call to the CU number).
3. Via a call from the machine room audio unit.
4. Using SMS commands (if your device is equipped with an LTE module).

Before you start programming via a call

- Make sure you have set the administrator and service passwords.
- Make sure that your phone supports the DTMF dialing option (key phones may cause problems in some PBXs).

Service password setting

1. Connect the device to the Service Tool.
2. If this is your first login, create an administrator password.
3. Go to **Devices > Information > Passwords**.
4. Enter the service password and save the changes.



TIP

If your device is equipped with an LTE module, you can set the admin and service passwords via SMS, see [Configuration by SMS \(p. 160\)](#).

Access to Programming Mode

You can enter the programming mode:

- during an incoming call (**2N Lift8** call), or
- from the machine room by pressing  (longer than 2 seconds)

Before entering, make sure you have set a service password. Without it, programming cannot be performed.

Access to Programming Menu



1. Once the connection is established, press **9** to enter the administration.
2. Press **1** to enter the programming menu.
3. Enter a service password in the format: `service password` .
4. If the password entered is correct, **2N Lift8** reports: "You have entered the programming menu, select a parameter".

**NOTE**

While entering the password, keep a timeout of 60 seconds (or any other value between 15 and 120) for each character to avoid **2N Lift8** hang-up.

Troubleshooting

2N Lift8 fails to respond correctly to DTMF commands, e.g. the programming mode cannot be entered.

1. Enter the function number (three digits) in the programming menu,
2. press ,
3. enter a value,
4. confirm .

The function number has three digits (see the table). After you enter the function number and an asterisk, **2N Lift8** reports the number or name, current value and potential range of the parameter to be programmed. After you enter the value and another asterisk, **2N Lift8** reports “New value stored”, or “Invalid value, new value not stored” if the value is beyond the allowed range.

In these cases, try calling from another device (for example, a digital PBX) or programming from the machine room audio unit. If **2N Lift8** cannot be programmed either from the machine room or PSTN, you must have probably entered an invalid service password.



**WARNING**

A drawback of some phones is that they go “deaf” for a fraction of a second whenever you press a button (i.e. send DTMF). In that case, you cannot hear the whole text and should use another phone.

Programming Error

- If you mistype a digit while entering a function/value and find it before clicking the asterisk, press  to cancel the whole number and enter a new one.
- If **2N Lift8** rejects a parameter number or value, you can go on programming – enter the function number although you typed a wrong value.
- If you have programmed and saved a wrong value, re-enter a correct value.

Programming End

- Press  to return to the preceding menu.
- If you are calling **2N Lift8** via a phone number, hang up to quit programming.
- If you are programming via the machine room audio unit, press and hold over 2 s  to terminate programming and put the audio unit in the standby mode.

Troubleshooting

2N Lift8 fails to respond correctly to DTMF commands, e.g. the programming mode cannot be entered.

Today, voice transmission is prevalingly digital, using variable compression algorithms. Therefore, the DTMF signal to be transmitted is often distorted. Moreover, it may, in some cases, be transmitted through the so-called command channel, whose delay may differ from that of the speech channel.

**CAUTION**

Experience shows that, especially recently, it is practically impossible to recover the DTMF signal in GSM networks!

In these cases, try calling from another device (for example, a digital PBX) or programming from the machine room audio unit. If **2N Lift8** cannot be programmed either from the machine room or PSTN, you must have probably entered an invalid service password.

Programming via Service Tool

Refer to [Service Tool \(p. 203\)](#) for Service Tool programming details.

Programming Using Lift DTMF config

The Lift DTMF config tool is used for remote programming **2N Lift8**. It provides easy remote programming via a phone line. The Lift DTMF config tool does not have to be configured. It is suitable for programming of a stand-alone **2N Lift8** device in particular.

To program identical parameters in multiple **2N Lift8** devices, it is advisable to use the procedure in the text below – Lift config group.

Use

It is necessary to create a *.csv configuration file including the required parameters to program **2N Lift8** using Lift DTMF config successfully.

The configuration file can include any number of programmable parameters (except for parameters 1xxx and services 8xxx). Refer to Subs. [Overview of All Programming Functions \(p. 129\)](#) for details.

**NOTE**

Enter lift_config.exe in the command row started in the folder with this file to display Help (for [download here](#) or at [2N.com](#)).

Help also displays an example of the configuration file and the parameter writing format.

Config file example:

```
Lift8Config
# comment - ignored
011;123456789
012;987654321
111;3
112;1
```

Example of Configuration File in Help

System Configuration

The configuration file can include any number of programmable parameters (except for parameters 1xxx and services 8xxx). Refer to Subs. [Overview of All Programming Functions \(p. 129\)](#) for details.

L8 – Poznámkový blok

Soubor Úpravy Formát Zobrazení Nápověda

```
| Lift8Config  
# comment - ignored  
016;123456
```

Example of Configuration File

Having created the configuration file, start the command row in the directory where the file is located. Upload the configuration file into to same directory as the .csv file or specify the path to the file on the command row. After upload, enter the following into the command row:

lift_config.exe space [Options] (see below for the options) space [phone_number] (intercom contact number) space [cfg_file] (configuration filer name and .csv file type)

```
\\12h\programy\Lift02.8.5.32.25\Lift Dtar Config>lift_config.exe -s proxy-5.my2n.com -u 1566587442 -l 12345 -p 90kFexv 156658741 L8.csv  
Registering to SIP server... ok.  
Calling 'sip:156658741@proxy-5.my2n.com'... ok.  
Waiting for remote party... ok.  
Initializing... ok.  
Data transfer complete.  
Parameters transfer succeeded.
```

Example of Configuration File Upload to Device

Options

Command	Description
-s	Sets the SIP server. By default, port 5060 is used, if another port is requested, enter it (e.g. proxy.2N.com:5065) after the SIP server.
-u	Sets the SIP server user name.
-a	Sets the SIP server authorization name.
-l	Resets the remote elevator unit password (parameter 991 – service password).
-r	Resets the device factory default values (full initialization does not delete parameters 1100–1115).
-t	Sets the user profile (parameter 850).
-p	Sets the SIP account password if authorization is required by the server.
-e	Sets the SIP server registration time limit (in seconds). The default value is 300 s.
-i	Sets the tool initialization timeout (in seconds). The default value is 3 s.
-w	Sets the incoming call waiting timeout (in seconds). The range is 0–3600. The default value is 0 s – no waiting for an incoming call.
-g	Sets the space between two DTMF characters sent. The default value is 400 ms.

Lift config group

Bulk commands are advised for bulk programming of a group of **2N Lift8** devices. It is necessary to:

- Complete a group configuration file with the configuration parameters (lift config group).
- Make a text file list of the phone numbers of the devices to be programmed.

[Download group configuration file here](#). Upload the configuration file into to same directory as the .txt file or specify the path to the file on the command row.

System Configuration

```
lifter - [c:\2N\2.8.53125\Lift Dtnf Config\lift_config_group.cmd]
Soubor Úpravit Množství Kódování Nápořádání
100 %
@echo off
:: Script
:: Name: lift_config_group.cmd
:: Desc: batch command call
:: Args: %1 ... <phone_list_file> - a text file with list of phone numbers
separated by line break (CRLF)

:: --- BEGIN of script configuration ---
:: break on error option:
:: ==0 - continue after lift_config error
:: <0 - break after first lift_config error
SET "break_on_error=0"
:: --- BEGIN of lift configuration configuration ---
SET "sip_server=server.sip.com"
SET "sip_username=sipuser"
SET "sip_password=abdef"
SET "lift_pass=abcde"
SET "cfg_file=liftconfig.csu"
:: --- End of configuration ---

set "phone_list_file=%*"
if "%phone_list_file%" == "" (
    echo Usage:
    echo lift_config_group.cmd "<phone_file>"
    echo
    echo phone_file ... a text file with list of phone numbers
    echo
    echo separated by line break "(CRLF)"
    echo.
    exit /B 1
)
echo [%*%] csv file with phones list: "%phone_list_file%"
if exist "%phone_list_file%" (
    for /F "usebackq delims;" %a in ("%*") do (
        echo [%*%] call lift_config.exe -s %sip_server% -u %sip_username% -l
        %lift_pass% -p %sip_password% %a "%cfg_file%"
        call lift_config.exe -s %sip_server% -u %sip_username% -l %lift_pass% -p
        %sip_password% %a "%cfg_file%"
        if not "%break_on_error%" == "0" (
            echo [%*%] BREAK script on error
            exit /B %errorlevel%
        )
    )
) else (
    echo [%*%] ERROR: file %phone_list_file% not found
    exit /B 2
)
exit /B 0
```

Lift config group Parameters

- sip_server
- sip_username
- sip_password
- lift_pass
- cfg_file – enter the configuration file name

Create a text file with a phone number list for the **2N Lift8** devices to be programmed – one number per row.

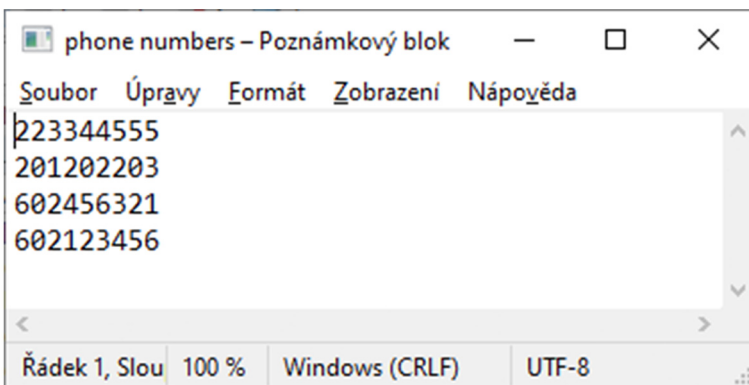

```
phone numbers - Poznámkový blok
Soubor Úpravy Formát Zobrazení Nápořádání
223344555
201202203
602456321
602123456
Řádek 1, Slou 100 % Windows (CRLF) UTF-8
```

Example of Phone Number Text File

Now start the command row in the folder with the above mentioned files to complete **2N Lift8** programming. The starting command is:

lift_config_group.cmd space "[phone numbers file]" (name of the phone number list text file including the .txt file type, in quotation marks)

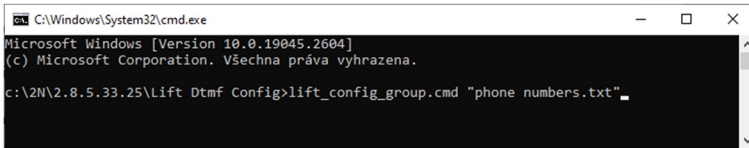

```
C:\Windows\System32\cmd.exe
Microsoft Windows [Version 10.0.19045.2604]
(c) Microsoft Corporation. Všechna práva vyhrazena.
c:\2N\2.8.5.33.25\Lift Dtmf Config>lift_config_group.cmd "phone numbers.txt"
```



Example of Group Configuration Start via Command Row

Once the command is started, the command row writes out gradual connections to the phone numbers and their programming.

Overview of All Programming Functions

The table below includes all the programming functions.

Table of Parameters

Par. No.	Parameter name	Range of values	Default value	Note
011	ALARM 1 button memory 1	up to 30 digits 0–9	empty	 <p>NOTE One calling destination has to be set at least (1 number in the ALARM button memory) according to the applicable EU standards.</p> <p>Entering characters ,  and “p” (1-second pause) is possible if programming via a PC (using the Service Tool) or parameter 017 is used.</p> <p>Enter # and the shaft number to call the machine room audio unit set as an intercom (refer to Subs. 4.7 for details)</p> <p>(e.g. #8 – alarm is set to the machine room audio unit in shaft 8).</p> <p>If the call is routed via SIP, enter “sip” before the phone number (sip:602123456, e.g.). This is only possible via the 2N Service Tool.</p> <p>The voice menu does not support entering this syntax . SIP calls can be made locally within the local network or you can connect Lift8 to a SIP server.</p> <p><i>The following applies to the LTE module only:</i> If the call is routed to a mobile network (2G, 3G, VoLTE), fill in the phone number (602123456, e.g.).</p>
012	ALARM 1 button memory 2	up to 30 digits 0–9	empty	
013	ALARM 1 button memory 3	up to 30 digits 0–9	empty	
014	ALARM 1 button memory 4	up to 30 digits 0–9	empty	
015	ALARM 1 button memory 5	up to 30 digits 0–9	empty	
016	ALARM 1 button memory 6	up to 30 digits 0–9	empty	

System Configuration

Par. No.	Parameter name	Range of values	Default value	Note
017	Inserting special character in ALARM 1 memory	4 digits (ABCD)	empty	<p>Value in the following format: ABCD</p> <p>A (first digit):</p> <ul style="list-style-type: none"> • 1 = * • 2 = # • 3 = pause <p>B (second digit):</p> <ul style="list-style-type: none"> • ALARM button memory number (1 – 6) <p>CD (third and fourth digits)</p> <ul style="list-style-type: none"> • character position (01 – 16) <p>Example:</p> <p>Adding the hash sign (#) to the first position of the number in memory 3: 2301</p> <p>The digits behind this position are shifted automatically.</p>
018	Count of automatic dialing cycles for ALARM 1	0–9	3	<p>If 0 is set, only the first number in the memory is called regardless of the count of stored numbers.</p>

Par. No.	Parameter name	Range of values	Default value	Note
021	ALARM 2 button memory 1	up to 30 digits 0–9		Entering characters * , # and p (1-second pause) is possible if programming via a PC (using the Service Tool) or parameter 027 is used.
022	ALARM 2 button memory 2	up to 30 digits 0–9		If Alarm memory set 2 is completely empty, use ALARM memory set 1. If parameter 029 = 0, the call will not be made.
023	ALARM 2 button memory 3	up to 30 digits 0–9		If the call is routed via SIP, enter <i>"sip"</i> before the phone number (sip:602123456, e.g.). This is only possible via the 2N Service Tool. The voice menu does not support entering this syntax. SIP calls can be made locally within the local network or you can connect Lift8 to a SIP server.
024	ALARM 2 button memory 4	up to 30 digits 0–9		<i>The following applies to the LTE module only:</i> If the call is routed to a mobile network (2G, 3G, VoLTE), fill in the phone number (602123456, e.g.).
025	ALARM 2 button memory 5	up to 30 digits 0–9		
026	ALARM 2 button memory 6	up to 30 digits 0–9		

System Configuration

Par. No.	Parameter name	Range of values	Default value	Note
027	Inserting specific character in ALARM 2 button memory	4 digits (ABCD)	empty	<p>Value in the following format: ABCD</p> <p>A (first digit):</p> <ul style="list-style-type: none"> • 1 = * • 2 = # • 3 = pause <p>B (second digit):</p> <ul style="list-style-type: none"> • ALARM button memory number (1 – 6) <p>CD (third and fourth digits)</p> <ul style="list-style-type: none"> • character position (01 – 16) <p>Example:</p> <p>Adding the hash sign (#) to the first position of the number in memory 3: 2401</p> <p>The digits behind this position are shifted automatically.</p>
028	Count of automatic dialing cycles for ALARM 2 button	0–9	3	<p>If 0 is set, only the first number in the memory is called regardless of the count of stored numbers.</p>

Par. No.	Parameter name	Range of values	Default value	Note
071	Checking call memory 1	up to 30 digits 0–9	empty	Entering characters * , # and p (1-second pause) is possible if programming via a PC (using the Service Tool) or parameter 077 is used.
072	Checking call memory 2	up to 30 digits 0–9	empty	If the Checking call memory set is completely empty, the first ALARM memory set is used.
073	Checking call memory 3	up to 30 digits 0–9	empty	Caution: Always set the checking call number that will route the call to the 2N Lift8 server. Falling down to set 011–016 may result in a call confirmation error.
074	Checking call memory 4	up to 30 digits 0–9	empty	If the call is routed via SIP, enter <i>"sip"</i> before the phone number (sip:602123456, e.g.). This is only possible via the 2N Service Tool.
075	Checking call memory 5	up to 30 digits 0–9	empty	The voice menu does not support entering this syntax . SIP calls can be made locally within the local network or you can connect Lift8 to a SIP server.
076	Checking call memory 6	up to 30 digits 0–9	empty	<i>The following applies to the LTE module only:</i> If the call is routed to a mobile network (2G, 3G, VoLTE), fill in the phone number (602123456, e.g.).

System Configuration

Par. No.	Parameter name	Range of values	Default value	Note
077	Inserting special character in checking call memory	4 digits (ABCD)	empty	<p>Value in the following format: ABCD</p> <p>A (first digit):</p> <ul style="list-style-type: none"> • 1 = * • 2 = # • 3 = pause <p>B (second digit):</p> <ul style="list-style-type: none"> • ALARM button memory number (1 – 6) <p>CD (third and fourth digits)</p> <ul style="list-style-type: none"> • character position (01 – 16) <p>Example:</p> <p>Adding the hash sign (#) to the first position of the number in memory 3: 2301</p> <p>The digits behind this position are shifted automatically.</p>
078	Count of automatic dialing cycles for checking calls	0–9	3	<p>If 0 is set, only the first number in the memory is called regardless of the count of stored numbers.</p>

Par. No.	Parameter name	Range of values	Default value	Note
081	Operational call memory 1	up to 30 digits 0–9	empty	Entering characters * , # and „p" (1-second pause) is possible if programming is made via a PC (using the Service Tool) or parameter 087.
082	Operational call memory 2	up to 30 digits 0–9	empty	Caution: Always set the operational call number that will route the call to the 2N Lift8 server . Falling down to set 011–016 may result in a call confirmation error and subsequent wrong call evaluation.
083	Operational call memory 3	up to 30 digits 0–9	empty	If the call is routed via SIP, enter "sip" before the phone number (sip:602123456, e.g.). This is only possible via the 2N Service Tool.
084	Operational call memory 4	up to 30 digits 0–9	empty	The voice menu does not support entering this syntax . SIP calls can be made locally within the local network or you can connect Lift8 to a SIP server.
085	Operational call memory 5	up to 30 digits 0–9	empty	<i>The following applies to the LTE module only:</i> If the call is routed to a mobile network (2G, 3G, VoLTE), fill in the phone number (602123456, e.g.).
086	Operational call memory 6	up to 30 digits 0–9	empty	

System Configuration

Par. No.	Parameter name	Range of values	Default value	Note
087	Inserting special character into error reporting memory	4 digits (ABCD)	empty	<p>Value in the following format: ABCD</p> <p>A (first digit):</p> <ul style="list-style-type: none"> • 1 = * • 2 = # • 3 = pause <p>B (second digit):</p> <ul style="list-style-type: none"> • ALARM button memory number (1 – 6) <p>CD (third and fourth digits)</p> <ul style="list-style-type: none"> • character position (01 – 16) <p>Example:</p> <p>Adding the hash sign (#) to the first position of the number in memory 3: 2301</p> <p>The digits behind this position are shifted automatically.</p>
088	Count of automatic dialing cycles for checking calls	0–9	3	<p>If 0 is set, only the first number in the memory is called regardless of the count of stored numbers.</p>

System Configuration

Par. No.	Parameter name	Range of values	Default value	Note
111– 116	ALARM 1 call mem- ory 1–6 confirma- tion mode	1–9	1	<p>1 = with DTMF confirmation (1)</p> <p>2 = with pick-up confirmation (for GSM/UMTS/VoIP only)</p> <p>3 = CPC Antenna</p> <p>4 = CPC Kone</p> <p>5 = P100</p> <p>6 = DTMF auto detection (CPC Antenna/P100)</p> <p>7 = CPC Antenna 2N Ext</p> <p>8 = CPC KONE 2N Ext</p> <p>9 = P100 2N Ext</p> <p>2N Ext is a protocol that transmits the shaft number and audio unit position together with the ID (to be displayed in 2N Lift8 Communicator).</p> <p>If a seamless DTMF transmission cannot be secured, specify the protocol to be used (3 or 5) rather than set 6 for CPC Antenna/P100 auto detection.</p>

System Configuration

Par. No.	Parameter name	Range of values	Default value	Note
121–126	Button 2 call memory 1–6 confirmation mode (ALARM 2)	1–9	1	<p>1 = with DTMF confirmation (1)</p> <p>2 = with pick-up confirmation (for GSM/UMTS/VoIP only)</p> <p>3 = CPC Antenna</p> <p>4 = CPC Kone</p> <p>5 = P100</p> <p>6 = DTMF auto detection (CPC Antenna/P100)</p> <p>7 = CPC Antenna 2N Ext</p> <p>8 = CPC KONE 2N Ext</p> <p>9 = P100 2N Ext</p> <p>2N Ext is a protocol that transmits the shaft number and audio unit position together with the ID (to be displayed in 2N Lift8 Communicator).</p> <p>If a seamless DTMF transmission cannot be secured, specify the protocol to be used (3 or 5) rather than set 6 for CPC Antenna/P100 auto detection.</p>
171–176	Checking call memory 1–6 confirmation mode	1–6	1	<p>1 = with DTMF confirmation (1)</p> <p>2 = with pick-up confirmation (for GSM/UMTS/VoIP only)</p> <p>3 = CPC Antenna</p> <p>4 = CPC Kone</p> <p>5 = P100</p> <p>6 = DTMF auto detection (CPC Antenna/P100)</p> <p>If a seamless DTMF transmission cannot be secured, specify the protocol to be used (3 or 5) rather than set 6 for CPC Antenna/P100 auto detection.</p>

System Configuration

Par. No.	Parameter name	Range of values	Default value	Note
181–186	Error reporting memory 1–6 confirmation mode	3–9	5	<p>1 = with DTMF confirmation (1)</p> <p>2 = with pick-up confirmation (for GSM/UMTS/VoIP only)</p> <p>3 = CPC Antenna</p> <p>4 = CPC KONE</p> <p>5 = P100</p> <p>6 = DTMF auto detection (CPC Antenna/P100)</p> <p>If a seamless DTMF transmission cannot be secured, specify the protocol to be used (3 or 5) rather than set 6 for CPC Antenna/P100 auto detection.</p>
501	Module 1 default output state	ABCD	empty	<p>Specifies the default state of outputs 1-4 on IO module 1 after the device is started.</p> <p>Each position (A-D) represents one output, where 0 means off and 1 means on.</p>
502	Module 2 default output state	ABCD	empty	<p>Specifies the default state of outputs 1-4 on IO module 2 after the device is started.</p>
503	Module 3 default output state	ABCD	empty	<p>Specifies the default state of outputs 1-4 on IO module 3 after the device is started.</p>
504	Module 4 default output state	ABCD	empty	<p>Specifies the default state of outputs 1-4 on IO module 4 after the device is started.</p>
505	Module 5 default output state	ABCD	empty	<p>Specifies the default state of outputs 1-4 on IO module 5 after the device is started.</p>

System Configuration

Par. No.	Parameter name	Range of values	Default value	Note
506	Module 6 default output state	ABCD	empty	Specifies the default state of outputs 1-4 on IO module 6 after the device is started.
507	Module 7 default output state	ABCD	empty	Specifies the default state of outputs 1-4 on IO module 7 after the device is started.
508	Module 8 default output state	ABCD	empty	Specifies the default state of outputs 1-4 on IO module 8 after the device is started.
600	Battery capacity	1–740	13	The unit corresponds to 100 mAh (x*100 mAh "13 = 1.3 Ah, 740 = 74 Ah")
700	SIM PIN	up to 8 digits: 0–9	0000	
710	DTMF transfer advanced mode enable	0–1	1	0 = disabled, 1 = enabled (if there is a problem with DTMF transmission via GSM, it is a good idea to enable this parameter)
711	Allowed bandwidths	1–3	3	Preferred mobile network (for UMTS module only) <ul style="list-style-type: none"> • 1 – 2G • 2 – 3G • 3 – Auto

System Configuration

Par. No.	Parameter name	Range of values	Default value	Note
901	Dial-in prefix	up to 30 digits	empty	<p>The parameter value is prefixed to dialing numbers for all outgoing calls.</p> <p>Dial-in is particularly useful for calls via the PSTN module where there is no dial/constant tone after pick-up. The dial-in prefix is sent after pick-up and the dial/constant tone is awaited.</p> <p>If the tone is detected, the number is dialed from the memory (dial-in is shared by all the memories 011-016, 021-026, 071-076, 081-086).</p>
902	Dial tone detection use	0–1	1	<p>0 – no dial tone detection is made. The call is set up at any tone on the line.</p> <p>1 – the dial tone is checked. If the tone is not detected, the call is not set up.</p>
911	Count of ringings until incoming call answering	1–9	2	<p>Define the line seizure moment during ringing (incoming call via a PSTN line).</p>
912	Maximum call duration	0–1000 s	120 s	<p>Use the call extending command (DTMF 4) to extend a call.</p> <p>0 = disabled (never-ending call)</p>
913	Login timeout	10–1000 s	60 s	<p>Set the maximum period of time for the control room staff to answer the call and send confirmation, otherwise L8 hangs up and dials the next number. Counted from the end of dialing.</p>

System Configuration

Par. No.	Parameter name	Range of values	Default value	Note
914	Delayed call	0–1000 s	0 s	<p>The function has to be set to more than 0 s according to the applicable EU standards.</p> <p>Applied only if the CANCEL input is connected.</p>
915	Max. TRIPHONY time	10–9999 s	7200 s	Maximum TRIPHONY time. When this time passes, TRIPHONY will automatically be terminated.
917	Hang-up timeout between calls	500–9999 ms	5000 ms	Applies to PSTN lines only.
918	Max. phone line test time	1–20 s	5 s	<p>Applies to PSTN modules only. If the line is OK, the check is made every hour. Lift8 picks up the line and detects the dial tone. If no dial tone is detected, the line will be checked every 2 minutes (the line will pass into error in 6 minutes and the elevator will be blocked in another 5 minutes).</p> <p>If the dial tone is detected again, Lift8 switches into the Line OK state in 1 min.</p>
919	Siren trigger on machine room audio unit	1–1000 s	0	<p>The alarm call triggers the machine room siren for the preset time of the parameter.</p> <p>0 = function disabled</p>

System Configuration

Par. No.	Parameter name	Range of values	Default value	Note
925	Button 2 mode	0–2	0	<p>0 = NO contact (alarm generated by contact closing or presence of voltage on input)</p> <p>1 = NC contact (alarm generated by contact opening or absence of voltage on input)</p> <p>2 = auto detection (connected contact type auto detection on subsequent launch, parameter value changed to detected type)</p>
940	Min. dial tone time	200–2000 ms	400 ms	The tone must be longer than the half-period of the busy tone.



System Configuration

Par. No.	Parameter name	Range of values	Default value	Note
942	Min. busy tone period	100–500 ms	200 ms	Use these parameters to adjust the busy tone detection.
944	Max. tone – gap difference of busy tone	10–400 ms	50 ms	
945	Min. count of busy tone periods	2–50	5 4	
948	Min. ring-back tone time	50–2000 ms	200 ms	For outgoing call detection: The ring-back tone time is a time interval before the long gap. The longest gap in the ringing period must be in the interval between parameters
949	Min. ring-back tone long gap time	100–5000 ms	2000 ms	
950	Max. ring tone long gap time	500–9999 ms	5500 ms	

System Configuration

Par. No.	Parameter name	Range of values	Default value	Note
951	Min. ring tone time	50–2000 ms	200 ms	For incoming call detection:
952	Min. ring tone long gap time	100–5000 ms	1000 ms	The ringtone time is the sum of the sections between which there is no long gap. The longest gap in the ringing period must be in the interval between parameters 952 and 953.
953	Min. ring tone long gap time	500–9999 ms	6000 ms	ATTENTION! Parameters 951–953 work (defaults) for incoming ringing.
955	Checking call ringing periods	1–99	10	Count of ringing periods for alarm/ checking calls Hangs up after this count and dials the next number if Automatic dialing is enabled.
961	Max. timeout for pressing the next digit	5–120 s	60 s	Counted from transition to a new state (NOT after the announcement ends)
962	Min. ALARM button pressing time in cabin	100–9999 ms	3000 ms	The maximum value may not exceed 3000 ms according to the applicable EU standards. The recommended range is 2000 – 3000 ms.
963	Min. button press time for forced/ test alarm	0–30 s	0	<p>The minimum time in seconds the alarm button needs to be pressed to activate the forced/test emergency call. This alarm bypasses the cancel contact status.</p> <p>0 = disabled</p> <p>The value has to be set to 30 s according to the applicable EU standards.</p> <p>The set time value must be higher than the time value set for Minimum ALARM button press time (parameter 962).</p>

Par. No.	Parameter name	Range of values	Default value	Note
965	Privacy mode	0-25	0	<p>The privacy mode allows you to mute the microphone on the unit. Setting options:</p> <p>0 = two-way communication enabled during the rescue.</p> <p>1–24 (hours) = two-way communication enabled during the rescue and within a certain time after a successful alarm call. When the time elapses, the microphone is muted.</p> <p>25 = two-way communication is always enabled.</p>
966	Rescue mode	0–3	0	<div style="border: 1px solid gray; padding: 5px; margin-bottom: 10px;">  <p>NOTE The function has to be enabled according to the applicable EU standards.</p> </div> <p>0 = disabled</p> <p>1 = end the rescue process with button 2</p> <p>2 = end the rescue process with password</p> <p>3 = end the rescue process with button 2 or password</p>

Par. No.	Parameter name	Range of values	Default value	Note
968	Alarm call type	0–2	0	<ul style="list-style-type: none"> • 0 = not set (default setting) • 1 = queue Alarm calls are queued. • 2 = conference Alarm calls from the COP and Compact audio units are combined into a single conference call. The next audio unit that triggers the alarm call will immediately join the ongoing call.
<div style="border: 1px solid gray; padding: 10px; background-color: #f0f0f0;"> <p> NOTE The default type is conference for the US version.</p> <p>The default type is queue for the other versions.</p> </div>				
969	ALARM button test	0–9999 s	0	<div style="border: 1px solid gray; padding: 10px; background-color: #f0f0f0;"> <p> NOTE The function has to be enabled according to the applicable EU standards.</p> </div>
<p>0 = not tested</p> <p>1–9999 = closing time after which a button is considered stuck.</p> <p>If a button is evaluated as stuck, an event is generated – I/O module switch on/off, operational call setup, SMS sending (for LTE only). Configuration is made via the Service Tool in the event menu.</p>				

System Configuration

Par. No.	Parameter name	Range of values	Default value	Note
972	New shaft number announcement	16 digits	1	Two identical digits indicate a new shaft number. E.g. 1122334455667788, pair of digits 33 will announce the audio unit in shaft 3.
973	Numeric announcement language	0–1	1	0 = user recorded messages 1 = voice menu language The user recorded digits are played if parameters 975–979 or 971 are set to 11, 12 or 13.
974	Elevator identification number	up to 16 digits: 0–9	empty	Provides numeric elevator identification.

System Configuration

Par. No.	Parameter name	Range of values	Default value	Note
971	Call end sequence	up to 10 announcements in succession	empty	You can start announcements in multiple languages in a given order. The sequences may include such numeric data as elevator number, etc.
975	Cabin message sequence (Alarm)	up to 10 announcements in succession	empty	List of announcements: 01 = user message 1 02 = user message 2
976	Control center report sequence (before confirmation with 1)	up to 10 announcements in succession	empty	03 = user message 3 04 = user message 4 05 = user message 5 06 = user message 6 07 = user message 7 08 = user message 8
977	Checking announcement sequence	up to 10 announcements in succession	empty	09 = user message 9 10 = user message 10 11 = product number (reads Central Unit product number)
978	Message sequence after connection confirmation	up to 10 announcements in succession	empty	12 = identification code (reads par. 974 value) 13 = number of the shaft from which the call is coming (1–8) 14 = pause (2 s)
979	Control center report sequence after pressing 3 after call confirmation	up to 10 announcements in succession	empty	15 = (confirmation tone) Caution: User messages #1 through #10 are recorded into the Central Unit via the Service Tools.

Par. No.	Parameter name	Range of values	Default value	Note
981	Checking call mode	0–6	0	<div style="border: 1px solid gray; padding: 5px; background-color: #f0f0f0;">  <p>NOTE The function has to be enabled according to the applicable EU standards.</p> </div> <p>0 = disabled</p> <p>1 = enabled, first call in 3 minutes and then according to par 983, no call in the time interval according to parameter 982</p> <p>2 = enabled, first call in 2 hours and then according to par 983, no call in the time interval according to parameter 982</p> <p>3 = enabled, calls in the time interval specified in parameter 982 and then calls periodically as set in parameter 983</p> <p>4 = enabled, calls on the nearest day set in parameter 986</p> <p>5 = enabled, first call in 3 minutes and then as set in parameter 986</p> <p>6 = enabled, first call in 3 minutes and then as set by the server</p>
982	Checking call interval	hhmmhhmm	00002359	<p>Set that the announcements are played at a lower traffic (lower tariff) time, generated randomly in the set time interval.</p> <p>Par. 982 is applied only if par. 981 is set to 3 or 4.</p>

Par. No.	Parameter name	Range of values	Default value	Note
----------	----------------	-----------------	---------------	------

983	Checking call period	0–100 days	3 days	
-----	----------------------	------------	--------	--



NOTE

The checking call function must be performed at least once every three days according to the applicable EU standards.

0 = disabled (setting of parameter 981 to 0 has the same effect, the value is applied if parameter 981 is set to 1–6)

986	Days of week for checking calls	mtwtfss	0000000	
-----	---------------------------------	---------	---------	--



NOTE

The checking call function must be performed at least once every three days according to the applicable EU standards.

Values for Mon, Tue, Wed, Thu, Fri, Sat, Sun:

0 = do not call

1 = call

Example:

1000100 = checking call will be made on Mondays and Fridays

Par. No.	Parameter name	Range of values	Default value	Note
987	LED signaling according to EN 81-28	0–1	1	<div style="border: 1px solid gray; padding: 5px; background-color: #f0f0f0;">  <p>NOTE The function has to be enabled according to the applicable EU standards.</p> </div> <p>0 = disabled</p> <p>1 = yellow LED permanently on during an alarm call, yellow and green LED flashing alternately after an unsuccessful checking call</p>
988	I/O module output activation for button test	0–8	0	<p>Four numbers make up a logical complex; the number of fours is 0–8.</p> <p>E.g. 1340 – on 1. The I/O module activates output 3 and expects the button in shaft 4 to be activated at position 0 (cabin).</p>
992	Rescue password	up to 16 digits: 0–9	empty	Rescue process terminating password.
993	Automatic audio unit test enable	0–1	0	<p>0 = disabled</p> <p>1 = carry out an audio test of the audio units after the checking call</p>
994	4-elevator version enable	0–1	0	<p>0 = classic connection</p> <p>1 = up to 4 cabin audio units can be connected to the CU internal splitter as lifts elevators 1–4 (refer to Subs. 4.5 for details)</p>
995	Outgoing call enable	0–1	0	<p>0 = disabled,</p> <p>1 = enabled (you can call the PSTN via the machine room audio unit)</p>

System Configuration

Par. No.	Parameter name	Range of values	Default value	Note
996	Evacuation mode	0–1	0	0 = disabled, 1 = enabled (the whole system works in the Evacuation mode) Once the parameter is changed, the CU is restarted.
997	Count of evacuation messages played	1–99	1	The value defines how many times the evacuation announcement is played on the floor when sent from the control center.
1001	Data enable	0–1	0	Enable the LTE module connection to the provider's data network. **
1002	APN		empty	Set the access APN server of the mobile provider. **
1003	Login		empty	Set the user name for authentication in the provider's APN server. **
1004	Password		empty	Set the password for authentication in the provider's APN server. **
1005	Authentication type	0–1	0	Set the APN server authentication type. 0 = None 1 = PAP 2 = CHAP 3 = PAP, CHAP
1006	GSM DNS server 1		208.67.222.222	Set the DNS server IP address for GSM connection
1007	GSM DNS server 2		empty	Set the backup DNS server IP address for GSM connection

System Configuration

Par. No.	Parameter name	Range of values	Default value	Note
1100	DHCP client enable	0–1	1	The DHCP server assigns primarily the IP address, network mask, default gateway and DNS server address to devices via the DHCP. ** 0 = disabled 1 = enabled
1101	IP address		empty	IP address assigned to the Ethernet interface (VoIP module). **
1102	Subnet mask		empty	Gives the subnet bit mask. **
1103	Default gateway		empty	Set the router/PC IP address via which communication is made outside the internal network. **
1104	DNS server		208.67.222.222	Set the DNS server IP address. **
1120	DNS server 2		empty	Set the IP address of the backup DNS server. **
1105	Registration SIP server		empty	The parameter represents the IP address for login to the counterparty (PBX, operator). ** Mandatory parameter
1106	User	up to 64 characters	empty	The parameter represents the user name for login to the counterparty (PBX, operator). ** Mandatory parameter
1107	Password	up to 32 characters	empty	Represents the password for login to the counterparty (PBX, operator). **

System Configuration

Par. No.	Parameter name	Range of values	Default value	Note
1108	In-band DTMF detector enable	0–1	0	Enable the in-band DTMF detector (disabling the other DTMF detections).**
1109	SIP server port	1–65535	5060	Set the PBX (operator) port via which the SIP Proxy communicates with the terminals connected. **
1110	Registration validity	60–3600 s	300 s	**
1111	Authentication name		empty	Enter the name for the authentication request. If no name is completed, the User value is used (parameter 1106).
1112	Display name		empty	Enter the name to be displayed to the other party during the call. #A is replaced with the calling audio unit address, #S with the shaft number.
1113	Domain		empty	If no domain is completed, use the SIP registration server (parameter 1105).
1114	Outgoing Proxy		empty	Enter the server address for outgoing calls. If not completed, the SIP registration server address is used (parameter 1105).
1115	Outgoing Proxy port	1–65535	5060	Server port for outgoing calls. If no outgoing proxy is completed, the registration server port is used.
1116	Authentication type	SHA-256/M D5	SHA-256	Security algorithm for the encryption of your VoIP account login credentials.

System Configuration

Par. No.	Parameter name	Range of values	Default value	Note
1117	SIP Transport type	TCP/UDP	TCP	Network protocol used for call transmission within a VoIP service.
1150	Time zone	-12-12	1	Set the time zone (UTC) for 2N Lift8. **
1151	Synchronization period	60-86400 s	3600 s	Set how often Lift8 shall synchronize with the SNTP server. **
1160	SNTP on	0-1	1	SNTP synchronization enable ** 0 = disabled 1 = enabled
1161	SNTP server 1 address		212.51.14 4.44	**
1162	SNTP server 2 address		81.95.103 .173	**
1165	Communication speed	9600-115200	115200	RS 232 bit rate. **
1166	Device driver		AT SMS	
1220	Camera type	0-2	1	Settings moved to camera menu
1221	Resolution	0-4	2	Settings moved to camera menu
1222	Compression ratio	1-100	60	Settings moved to camera menu

System Configuration

Par. No.	Parameter name	Range of values	Default value	Note
1230	Client enabled	0–1	0	Data client enable (refer to Subs. 7.1 Control Panel for details). **
1231	Server address		empty	2N Lift8 server IP address **
1232	Server port	1–65535	7008	Set the port via which the data client communicates. **
1234	Password			The password must match the password set for the given intercom in the Control Panel. **
1500	IP address	0.0.0.0–255.255.255.255	0.0.0.0	IP address of the data LAN module.
1501	Subnet mask	0.0.0.0–255.255.255.255	0.0.0.0	Subnet mask for the data LAN module.

* This parameter can only be set via the voice menu (incoming call to Lift8 or via the machine room audio unit).

** This parameter can only be set via the Service Tool.



WARNING Warning

- Parameters 1003 and 1004 set the user name and password for provider authentication. Most providers use no authentication. If your provider requires authentication, ask for necessary access data.

Service parameters

These parameters cannot be set or started via the Service Tool. Enter an asterisk (*) after the value to set the service parameters (800, 801 and 811).

Service parameters

Parameter number	Parameter name	Parameter range	Default value	Note
800	Time setting	hhmm		Reads the current time setting and set a new one if necessary.
801	Date setting	RRMMDD		Reads the current date setting and set a new one if necessary.
810	Time until the next checking call activation	hhmmss		The voice menu reads the value in the format of hours, minutes and seconds (hhmmss). It indicates when the next checking call will be activated.
811	Checking call manual activation	-empty-		The service is activated upon confirmation with an asterisk (*). The checking call is set up the moment the programming is completed.
890	CU restart	-empty-		The service is activated upon confirmation with an asterisk (*).
891	Service password setting	min. 6 digits up to 16 digits: 0–9	n/a	Programming password change (the programming password is used for access to the programming mode via a voice menu and for full initialization)
898	Cancel work configuration	-empty-		Cancel the changes made during this configuration call except for the date and time values! Use an asterisk for confirmation.
899	Full initialization (including the service password!)	service password	service password	Enter the service password instead of the value to activate the service. Re-enter the valid service password (to avoid unwanted deletion due to wrong function number entering). (Parameters 1100–1115 are not deleted during full initialization)

Configuration by PC

Install the **2N Service Tool** for this purpose.

This application allows you to configure L8, which is connected directly to the PC via USB or the Internet using the Lift8 IP address (UMTS version only). Firmware upgrade (upgrade) is also possible.

Install and launch the **2N Service Tool** from the CD enclosed for more information.

Refer to <http://www.2n.cz/Lift8> for the latest program version.

How to record a message

From a PC

The Service Tool is designed for recording user messages and digits into the **2N Lift8** elevator communicator.

Configuration by SMS



CAUTION

The SMS configuration function is supported only on condition that the CU is equipped with an **LTE module** (918658G).

The SMS commands help you configure the Central Unit easily without using a PC. All you need for a proper function is to know the phone number of the SIM card inserted in the **2N Lift8** Central Unit and set **the administrator password**.



NOTE

The device cannot be configured without an **administrator password**. The Service Tool application requires the administrator password to be created upon the first login. You can change the password any time in **Device > Info > Passwords**.

If the device is equipped with an LTE module, set the administrator password using the PWD SMS command.

Function Description

You can configure the **2N Lift8** system with an LTE module using SMS messages. Send the SMS to the CU SIM card phone number. Make sure that all the parameters to be entered are correct. If an SMS parameter is incorrect, the SMS will not be processed, changes will not be made and an error response will be sent.

SMS Command Rules

Every configuration SMS must meet the following conditions!

- L8 name
- Correctly formatted command (**CNF**, **RST**, etc.)
- Central Unit administrator password (as set in the Service Tool or via a **PWD** command)
- Correctly formatted parameters
- Separate the parameters with a space

SMS Command Overview

Command	Purpose
PWD	Set administrator password
CNF	Parameter configuration
DEF	Factory reset
RST	Device restart
SET	Activate profile
INF	Device info

Set administrator password using PWD command

This command sets the administrator password for all other SMS commands.

Message syntax: **L8 PWD 2n <new administrator password>**

The password must contain 8 to 16 characters including at least one lowercase letter, one uppercase letter and one digit.

“SermoTutus2N” Administrator Password Setting

```
L8 PWD 2n SermoTutus2N
```



NOTE

Set the administrator password in the Service Tool too.

Basic Settings (CNF)

All the 2N Lift8 Central Unit parameters can be set using a configuration SMS. Unlike setting via a call, the string-requiring parameters (IP address, e.g.) can be set too.

You can use the **CNF** command for setting services 800, 801, 811 and 891 only. Use the SMS commands **RST** and **DEF** to set parameters 890 (device reset) and 899 (factory reset).

Mandatory parts of configuration SMS

- L8 – header
- CNF – command type
- Administrator password

- Parameters: <parameter>=<value>
Add an asterisk * to the end of the value to set the services (starting with 8)
Service 811 has an empty value – the asterisk stands alone (see the example below).

Message syntax: **L8 CNF <admin password> <par1>=<val1> <par2>=<val2> ...**

Enter an empty value to delete the parameter values.

Enter String Parameters

The SMS commands help you enter text values too, such as IP addresses, domain names and SIP addresses. The following rules specify the correct format:

- Parameters 1000 and higher support direct text string entering (e.g. IP address 192.168.10.10 or domain name `ntp.2n.cz`).
- If the call is to be routed via *SIP*, the calling destination must be given the `sip:` prefix.
- Use the `sip:pp` prefix for parameters 011-016, 021-026, 071-076 and 081-086. These memories also support only entering an IP address, not a domain name.



NOTE

Parameters 011-016 do not support entering a domain name.

Examples of CNF Command Use

The “SermoTutus2N” administrator password is used for the purposes of these examples.

Setting parameters 011, 941, 012, 914, 111 and 112:

```
L8 CNF SermoTutus2N 011=734523352 941=99 012=602874321 914=105 111=5 112=1
```

Setting parameter 011 (call to SIP):

```
L8 CNF SermoTutus2N 011=sip:pp192.168.10.10
```

Setting service 811 (checking call initiation):

```
L8 CNF SermoTutus2N 811=*
```

Change of service password “123456” for access to the programming mode via a call (see [2N Lift8 Programming \(p. 123\)](#)).

```
L8 CNF SermoTutus2N 891=123456*
```

Deleting parameters 011 and 012:

```
L8 CNF SermoTutus2N 011= 012=
```

Response

If everything is OK, you will receive the following confirmation SMS:

```
L8 CNF OK
```



NOTE

The bus or GSM/UMTS may be restarted during SMS configuration. This means that new parameters have been set. The confirmation SMS is not sent until relogging in this case.

Factory Configuration Reset (DEF)

The **DEF** command resets the device configuration factory values.

Message syntax: **L8 DEF <admin password>**

The “SermoTutus2N” administrator password is used for the purposes of these examples.

```
L8 DEF SermoTutus2N
```

If everything is OK, you will receive the following confirmation SMS:

```
L8 DEF OK
```

Central Unit restart (RST)

The **RST** command performs a remote restart of the Central Unit. A confirmation SMS is sent before the restart.

Message syntax: **L8 RST <admin password>**

Example SMS

The “SermoTutus2N” administrator password is used for the purposes of these examples.

```
L8 RST SermoTutus2N
```

If everything is OK, you will receive the following confirmation SMS:

```
L8 RST OK
```

Profile change (SET)

Profile configurations are customized in 2N Lift8. The **SET** command is used for their activation. Once the command is received, the profile is factory reset immediately.

Message syntax: **L8 SET <admin password> <profile number>**

Example SMS

The “SermoTutus2N” administrator password is used for the purposes of these examples.

Profile number 4 settings

```
L8 SET SermoTutus2N 4
```

If everything is OK, you will receive the following confirmation SMS:

```
L8 SET OK
```

Device Info (INF)

The **INF** command returns an SMS with device info.

Message syntax: **L8 INF <admin password>**

Response info

FW	Firmware version
SN	Serial number
IMEI	Unique mobile module identification number
IMSI	SIM Card Identification Assigned by Provider
PROVIDER	Mobile provider name
BAT-STATE	Battery state and power supply <ul style="list-style-type: none"> • 0 – Unknown state • 1 – Mains powered, battery fully charged • 2 – Mains powered, battery charged • 3 – Battery powered, disconnected from mains • 4 – Battery operated, less than 1 hour of power left • 5 – Mains powered, no battery connected • 6 – Mains powered, battery too old
BAT-TIME	Minutes until battery charge/discharge according to BAT-STATE value: <ul style="list-style-type: none"> • BAT-STATE = 2 → Battery time until full charge • BAT-STATE = 3 or 4 → Battery time until discharge • Other statuses → BAT-TIME = 0

Example SMS

The "SermoTutus2N" administrator password is used for the purposes of these examples.

```
L8 INF SermoTutus2N
```

If everything is OK, you will receive the following confirmation SMS:

```
FW="3.1.5.x.x" SN="91-2222-3333"
IMEI="8679490XXXXXXXX" IMSI="2300150XXXXXXXX"
PROVIDER="T-Mobile CZ T-Mobile CZ" SIGNAL="81"
BAT-STATE="2" BAT-TIME="374"
```

The device is powered from the mains. The battery will be fully charged in 6 hours and 14 minutes.

Error Responses

Should there be an error in the configuration SMS or command processing procedures, **2N Lift8** transmits an error reply. If the CU generated such reply, the command was not executed!

2N Lift8 sends error replies until all the configuration SMS parameters are correct. Once everything is OK, the command can be executed. The following errors can occur:

- L8 ERR Unknown Command – an unknown command has been entered.
- L8 ERR Invalid Message – the received SMS has an invalid format. The L8 header is probably missing.
- L8 ERR Invalid Syntax – there is a syntactic error in the SMS. Probably the password - command order is incorrect or there is a redundant text at the end.
- L8 ERR Invalid password – administrator password missing or wrong.
- L8 ERR Invalid Parameter – a command parameter fails to match the CU parameters or the parameter value is beyond the limits.



NOTE

The language localization of the SMS reply is based on the voice menu recorded. So far there are texts for CS, EN.

Function Description

You can configure the **2N Lift8** system with an LTE module using SMS messages. Send the SMS to the CU SIM card phone number. Make sure that all the parameters to be entered are correct. If an SMS parameter is incorrect, the SMS will not be processed, changes will not be made and an error response will be sent.

It implies from what is said above that the maximum message length is 918–1224 characters with 7-bit encoding depending on the device used. The UCS-2 calculation is analogous.

Used Ports

Service	Port	Protocol	Direction	Configurable	Set up
RTP	9000	UDP	In/Out	NO	–
DHCP	68	UDP	In/Out	NO	–
DNS	53	TCP/UDP	In/Out	NO	–
2N Service Tool	7007	TCP	In/Out	NO	–
Data Client	7008	TCP	In/Out	YES	Port 2N Call Center
SIP Registration	5060	TCP/UDP	In/Out	YES	–
SIP Outgoing Proxy	5060	TCP/UDP	In/Out	YES	–

Communication in Elevator Shafts

In the default mode, **2N Lift8 (L8)** operates as a communication system providing mutual communication and control room connection for the audio units located in the elevator shaft. The system is controlled by the Central Unit (CU), which ensures the interconnection of the connected audio units and the central control room. The elevator cabin, shaft and machine room audio units are connected to the CU via splitters. Each splitter is designed for use in one elevator shaft. The CU is equipped with an internal splitter of its own. Up to 7 additional splitters can be connected to the CU. Hence, the **2N Lift8** system is capable of ensuring communication for up to 8 elevator shafts (CU + 7 splitters). Up to 8 audio units can be connected to the splitter depending on the Lift8 CU batch.

Up to 7 audio unit locations are available within each elevator:

1. Cabin 1 roof
2. Inside cabin 1
3. Under cabin 1
4. Shaft bottom
5. Cabin 2 roof
6. Inside cabin 2
7. Under cabin 2

A Fireman audio unit or an MEEF evacuation audio unit can be connected to the system, being located outside the shaft and activating the priority call with the elevator cabin.

Basic Features

- Up to 8 elevator connectivity
- Variable communication interfaces (ethernet, PSTN, GSM, UMTS, VoIP, LTE)
- Audio units for the cabin, shaft, machine room, emergency services
- Optimum acoustic properties
- In-built backup rechargeable battery
- Easy control and configuration – voice menu
- Checking call function
- Elevator blocking option during connection error
- Internal communication – Triphony
- Remote maintenance
- Periodical automatic function check
- Configuration via phone or PC (USB/Internet)
- USB interface
- User message recording option
- Local control option (InterCom)
- Fireman function

System diagram

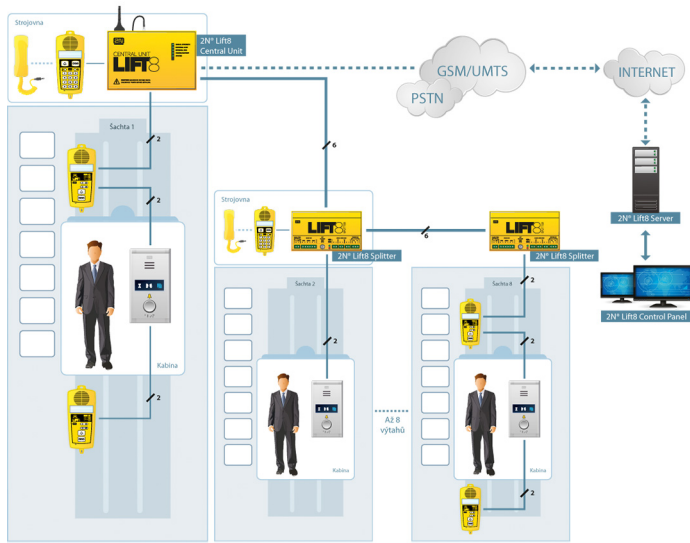

Example of 2N Lift8 Central Unit, Splitter and Audio Unit Wiring

Main bus

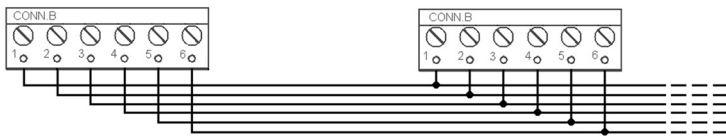

Bus (audio units)

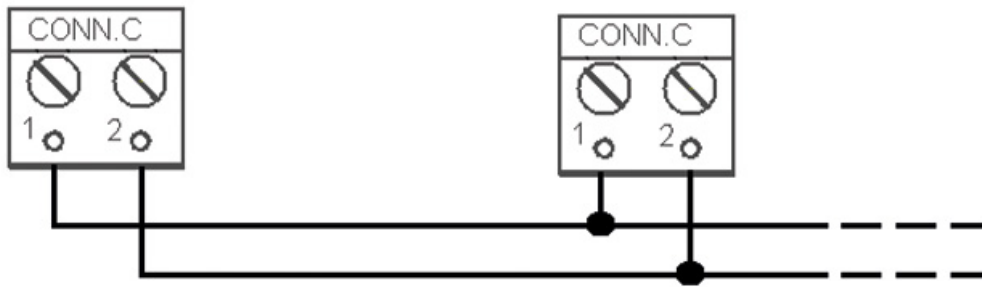

User Instructions

Cabin

The cabin audio unit is intended for an untrained user. Nevertheless, the instructions can be placed in the cabin, e.g., to help the people trapped in the elevator communicate with the control room.

Meaning of pictograms (icons)

- The yellow "Wait" icon is illuminated while connection with the control room is being set up.
- The green icon lights up when connection has been set up and confirmed by the control room.
- The green icon lights up whenever **TRIPHONY** is in progress.
- The blue icon does not shine, but marks the place where a signal is radiated during the call for people with defective hearing equipped with hearing aids.

Shaft, Cabin Roof

- Press the **ALARM** button to call the control room using the **ALARM** 2 numbers (parameters 021–026). If the parameter is not filled in, it calls the **ALARM** numbers (parameters 011–016) like the cabin.
- Pressing the **TRIPHONY** button to call the other audio units in the same elevator (shaft).
- Hold the **TRIPHONY** button (for approximately 2 s) to retrieve the voice menu to call the other shafts via **TRIPHONY**.
- Re-press the **TRIPHONY** button to terminate this connection.
- The **ALARM** button is illuminated in the standby mode.
- The **ALARM** button flashes when a calling is being set up.

- The **TRIPHONY** button is not illuminated in the standby mode.
- The **TRIPHONY** button flashes and the green LED indicator is illuminated if **TRIPHONY** is active between the elevators.
- The yellow LED indicator is illuminated if connection is being made with the control room.
- The green LED indicator is illuminated if connection has been made and confirmed by the control room.

Machine Room

Everything that refers to the shaft audio unit applies here too. Press  (for more than 2 s)

to display the machine room voice menu. You can use the handsfree mode or connect a handset to achieve better acoustic properties.

Having entered the voice menu, you can select the following functions using the audio unit keypad.

Press 0 to dial the public telephone network

Enter elevator number X to dial the elevator

Press 1 to dial the elevator cabin

Press 2 to dial the cabin roof

Press 3 to dial the elevator cabin bottom

Press 4 to dial the shaft bottom

Press 5 to dial the machine room

Press 6 to dial the elevator cabin 2

Press 7 to dial the cabin 2 roof

Press 8 to dial the elevator cabin 2 bottom

Press # to return to the main menu

Press 9 for administration

Press 1 to enter the programming menu

Press 2 to terminate the rescue process

Press 3 for communicator info

Press 4 for I/O module administration

Press # to return to the main menu

Press # to terminate the call



NOTE

Option 9 is mainly used for 2N Lift8 configuration – refer to the [Configuration \(p. 123\) Subs.](#)

Control Room Instructions

ALARM Call

1. Press the **ALARM** button on any audio unit. When this button is pressed, **2N Lift8** calls the control room (refer to Automatic Dialing for details).
2. A received call is either confirmed as configured (parameters 111–116 > Confirmation mode for **ALARM** call memory 1–6 – set 1). By default, confirmation of DTMF 1 is set in **2N Lift8**.
3. If the control room is equipped with the 2N Communicator application, you can configure automatic sending of DTMF 1 after call pick-up.
4. The call is time-limited (by the "Caution, the call is ending" message), but can be prolonged using button 4.
5. It is advisable to end the call by pressing 5 or #.

Control Room-to-Elevator Calling

The control room can also call back to the communicator. The CU automatically receives every incoming call, identifies itself and, via a voice menu (DISA), offers you another function. Thus, you can get through to the required audio unit. Incoming calls are time-limited like outgoing calls and are processed in the same way (extension, termination).

Incoming Call Voice Menu:

Welcome, this is a 2N Lift8 communicator

Press 0 to dial the last-calling audio unit

Enter elevator number X to dial another audio unit

Press 1 to dial the elevator cabin

Welcome, this is a 2N Lift8 communicator

Press 2 to dial the cabin roof

Press 3 to dial the elevator cabin bottom

Press 4 to dial the shaft bottom

Press 5 to dial the machine room

Press 6 to dial the elevator cabin 2

Press 7 to dial the cabin 2 roof

Press 8 to dial the elevator cabin 2 bottom

Press # to return to the main menu

Press 9 for administration

Press 1 to enter the programming menu

Press 2 to terminate the rescue process

Press 3 for information on this communicator

Press 4 for I/O module administration

Press # to return to the main menu

Press # to end the call

The menu above makes it possible to call the selected audio unit.



CAUTION

- Press # to go one level back in the voice menu.
- You can also terminate a call using #, but only on the highest voice menu level: Press 0 for connection with the last-calling audio unit, Enter the elevator number X for connection with another audio unit, Press 9 for administration, information or rescue process, and Press # to end the call.



CAUTION

Calling the elevator that last triggered **ALARM**

- In the voice menu, it is possible to select the elevator that last invoked the **ALARM** function. Press 0 to do so.
- This function operates only if you are calling **2N Lift8** via a PSTN, GSM, UMTS, LTE(VoLTE) or VoIP network.



NOTE

The 9 selection serves primarily for the **2N Lift8** configuration – refer to S. [System Configuration](#) (p. 123).

Tone Dialing Control during Call – Long Command List

Tone dialing can be used for **2N Lift8** control during calls as shown in the table below if Automatic dialing with confirmation is enabled. Commands 1 through 5 are arranged conveniently for typical use.

DTMF symbol	Function description
1	Only if Automatic dialing repetition is enabled (with confirmation DTMF 1). This confirmation lets 2N Lift8 know that the call was successful. 2N Lift8 mutes the played-back announcement and, optionally, sends the identification code (DTMF). The call goes on until the timeout end and any of the following commands may be used.
5	Announcement playing end.
3	Repeated voice module playback for one replaying of the announcement.
4	Call extension: the call is extended as defined in parameter 912 (120 seconds by default) upon this command. Can be used repeatedly.

DTMF symbol	Function description
5 or #	Call termination (does not work until the call is confirmed).

The above table applies to Loud automatic dialing with confirmation.



WARNING

Rarely, **2N Lift8** may not identify the above listed commands reliably during message playing or voice communication. This is due to the essential principle of the telephone line function where DTMF signaling is mixed with the call and thus may be masked by certain speech tones or noise. This, however, is not a defect of the product. It occurs very rarely.

Function Description (for Advanced Users)

Purpose of this section

The purpose of this section is to provide aid in troubleshooting. If the system fails to work correctly, a qualified technician is commissioned to follow its operation according to the descriptions included herein. Having found a discrepancy between a description and reality, the technician describes this discrepancy, which significantly accelerates finding of the trouble cause. This procedure often reveals that the system works properly but the user had a different idea of its function.

Outgoing Call

The process starts whenever the **ALARM** button is pressed on any audio unit (in the cabin audio units, the CANCEL input may delay or block calling, refer to parameter 914). When the **ALARM** button is pressed, **2N Lift8** establishes connection with the control room (refer to Automatic Dialing for details). **2N Lift8** plays the message "Wait please, I'm making a connection" to the person in the elevator and the instruction for the control room: "Press 1 to confirm" (if DTMF confirmation 1 is used).

It is necessary to confirm the call manually or automatically. The call is time-limited (by the "Caution, the call is ending" message), but can be prolonged. Refer to the Control Room Instructions Subs. for control during a call (DTMF dialing).



CAUTION

The **ALARM** buttons on the shaft and machine room audio units are always illuminated in the standby mode.

Outgoing Machine Room Calls

You can call any audio unit of the same **2N Lift8** from the machine room (i.e. from the machine room audio unit, Part No. 918611E), activate functions and configure the **2N Lift8** parameters.

Press and hold for over 2 s  to activate the machine room voice menu. The **TRIPHONY** button can be used for connection with the other audio units of the same elevator. If you press the **TRIPHONY** button (for more than 2 seconds), you will get to the voice menu to set up Triphony with the other shafts.

Machine Room Voice Menu:

Press 0 to dial the public telephone network

Enter elevator number X to dial the elevator

Press 1 to dial the elevator cabin

Press 2 to dial the cabin roof

Press 3 to dial the elevator cabin bottom

Press 4 to dial the shaft bottom

Press 5 to dial the machine room

Press 6 to dial the elevator cabin 2

Press 7 to dial the cabin 2 roof

Press 8 to dial the elevator cabin 2 bottom

Press # to return to the main menu

Press 9 for administration

Press 1 to enter the programming menu

Press 2 to terminate the rescue process

Press 3 for information on this communicator

Press 4 for I/O module administration

Press # to end the call



CAUTION

- Press # to go one level back in the voice menu.
- Press and hold # (for more than 2 s) or move to the top menu and press # to quit the voice menu.

TRIPHONY

TRIPHONY provides interconnection of audio units within one shaft. Press the **TRIPHONY** button in the machine room to set up triphony with another shaft. This mode features different settings of the automatic handsfree mode. The microphones of active audio units are less sensitive than those operating in the **ALARM** mode.

TRIPHONY termination options

- re-pressing of the **TRIPHONY** button
- expiry of the time limit
- incoming call/ **ALARM** – processed preferentially



CAUTION

The **TRIPHONY** button on the shaft and machine room audio units is off in the idle mode.

Checking Call

A checking call is an automatically made outgoing call (typically every 3 days). The purpose is to check the correct function of the system. This call is usually processed automatically in the control room.

A checking call can be sent to the control room via PSTN, GSM, UMTS, LTE(VoLTE) or VoIP. Set the values in parameters 071–076 and 981 (refer to Subs. 3.2, Table of Parameters).



CAUTION

- Make sure that parameter 974 is completed where the elevator Id is evaluated in the checking call transmission (applies to CPC and P100).
- If the Checking call memory set is completely empty, the first **ALARM** memory set is used.



WARNING

With CPC or P100, be sure to set the checking call number to route the call to the **2N Lift8** server. The call may not be confirmed and evaluated properly if it falls to sets 011–016.



CAUTION

Use parameter 811 to manually start a checking call. The regular checking call schedule is not affected.

Operational Call

An operational call is made automatically when an event is executed (stuck button, battery replacement, rescue end, audio error). Use the Service Tool Configuration – Events menu for configuration. Refer to Subs. 5.3 for details.

These calls can be set up via the CPC or P100 protocols only (OK confirmation can only be made via CPC 2N ext or P100 2N ext).

If the operational call number is not entered, the call is set up via memories 011–016.



WARNING

Be sure to set the checking call number to route the call to the **2N Lift8** server. The call may not be confirmed and evaluated properly if it falls to sets 011-016.



TIP

For operational calls set the CPC Antenna 2N ext, CPC KONE 2N ext and P100 2N ext protocols, which allow the OK confirmations to be sent (batteries replaced, button fixed, audio repaired). You cannot set up these operational calls using protocols without 2N ext.

Incoming Call

The control room can also call back to the communicator. The CU automatically receives every incoming call, identifies itself and, via a voice menu (DISA). Thus, you can get through to the required audio unit. Incoming calls are time-limited like outgoing calls and processed in the same way (extension, termination).

Press 0 in the voice menu for connection with the last-calling audio unit.

Incoming Call Voice Menu:

Welcome, this is communicator

.....

Press 0 to dial the last-calling audio unit

.....

Enter elevator number X to dial another audio unit

.....

Press 1 to dial the elevator cabin

.....

Press 2 to dial the cabin roof

Press 3 to dial the elevator cabin bottom

Press 4 to dial the shaft bottom

Press 5 to dial the machine room

Press 6 to dial the elevator cabin 2

Press 7 to dial the cabin 2 roof

Press 8 to dial the elevator cabin bottom

Press # to return to the main menu

Press 9 for administration

Press 1 to enter the programming menu

Press 2 to terminate the rescue process

Press 3 for information on this communicator

Press # to return to the main menu

Press # to end the call

Call Queuing

If another request arises during an ongoing communication, we speak of call queuing. Calls have different priorities – the Fireman function has the highest priority, followed by the **ALARM** button press. These calls suspend any lower-priority call. Calls with identical priorities are queued and processed one after another. Having done that, **2N Lift8** recovers the suspended activity if possible.

Ongoing new event:	Incoming Call	Programming	Checking Call	ALARM	TRIPHONY	Fireman
Incoming Call	na	ns	na	na/ns	P	ns
Checking call time	z	z	na	z	z	z
Entering voice menu on machine room audio unit	ns	ns	ns	ns	ns	ns*
"TRIPHONY" button press	ns	ns	ns	ns	ns	ns
ALARM button press	P	P	z	z	P	z
Fireman function	P	P	P	P	P	z

Explanations:

- na = not applicable
- ns = not served (ns* > for the machine room configured as the control room, the Fireman call is entered whenever the phone is answered)
- q = put in queue
- S = suspends ongoing activity

Automatic Checking/Operational Call Answering

A control room equipped with a **2N Lift8** Server PC workplace receives calls automatically. Configure the server using the **2N Lift8** Control Panel. The checking call is automatically answered (according to the **2N Lift8** settings).



CAUTION

- If the checking call number (071–076) is not set, the call is made to the numbers in memories 011–016. Therefore, we advise you to always set the checking call number. If the CPC or P100 protocols are used and the call is directed to **2N Lift8** Communicator, the call will not be evaluated correctly.
- Operational calls can only be made via the CPC or P100 protocols. If memories 081–086 are empty, the call falls to the alarm numbers if the CPC or P100 confirmation mode is available. **2N Lift8** Communicator cannot evaluate such calls.



WARNING

- Once fallen to the alarm numbers, the call may be confirmed incorrectly and evaluated as error if the checking call number is not entered.
- If the operational call number is not entered, the call to **2N Lift8** Communicator is evaluated as alarm. Therefore, set the right number to direct the call to the **2N Lift8** server for proper evaluation and display in the **2N Lift8** Control Panel.



TIP

Set a number for alarm calls and another for checking and service calls.

Announcements

Announcement	Meaning
“Wait please, I’m making a connection”	The announcement is played to the elevator user when the call is being set up (before confirmation).
“This is an alarm call”	The announcement is played to the control room before call confirmation.
“Connection confirmed”	The announcement is played after call confirmation.
“This is communicator with product number/ Id ...”	The announcement is played only if the control room presses DTMF 3 after call confirmation. The communicator sends information on its product number or Id if available (parameter 974).
“Caution, the call is ending”	The announcement signals during an outgoing/incoming call that the maximum call duration shall expire in 10 seconds.
“Call end”	The announcement is sent before hang-up.
“This is a checking call...”	The announcement is sent to the control room only (if DTMF 1 confirmation is enabled).

Call End (Outgoing/Incoming)

The call end (line hang-up) occurs whenever any of the below listed situations happens:

- The busy or continuous tone is detected (PBX call end).
- The call confirmation timeout has expired (see parameter 913 setting).

- The configured maximum call time has been exceeded (parameter 912). 10 seconds before the expiry, **2N Lift8** plays “Caution, the call is ending” for you to extend the call with **4**.
- The **5** or **#** symbol has been received.
- The time limit expires during programming.
- A higher-priority call request has arrived.

Call Confirmation Types

These settings apply both to alarm (sets 1, 2) and checking calls and trouble reports.

1. With DTMF Confirmation

Up to 6 phone numbers and a repetition count can be stored for calls to the control room. **2N Lift8** then tries to call the set numbers one by one. **2N Lift8** uses tone dialing (DTMF) as the most reliable confirmation method. The control room staff has to press the **1** button on their phone (in the tone dialing mode) during manual call answering. If the called number is busy or unanswered within a timeout or unconfirmed, **2N Lift8** dials the next number in the sequence until it exhausts the preset count of attempts for all the numbers stored. Checking calls or failure reports are made equally, yet a separate set of 6 numbers can be used.

Evaluation of Dialing with Confirmation Situations

Situation	2N Lift8 Activity
No dialtone is detected on the line (PSTN).	Lift8 seizes the line and hangs up after a moment. The call will not be set up.
Busy tone after dialing end	Lift8 hangs up and dials the next number.
Call or silence (after dialing end)	Lift8 waits for a timeout (see parameter 913).
Call Ringtone	Lift8 waits for a timeout (see parameter 913).
Continuous tone (on PBX line, e.g.)	Lift8 hangs up and dials the next number.
DTMF character 5 or #	Lift8 hangs up immediately and dials the next number.
DTMF character 1	Lift8 confirms the connection (“Connection confirmed”), mutes the currently played announcement and the call goes on for the maximum call time as configured.
12345	These digits are interpreted as control characters (refer to Subs. Control Room Instructions (p. 170) , Tone Dialing Control during Call).



NOTE

The PSTN connection quality is not so high as to identify the above mentioned situations reliably in all cases. In addition, excessive noise in the cabin can adversely affect (decelerate) automatic dialing making it impossible to recognize the busy tone, for example. In general, DTMF is the most reliable type of signaling and so is used for confirmation. Thus, the connection is established (yet for a shorter time than usual) even in extreme cases, e.g. when 2N Lift8 cannot identify the DTMF.

2. Automatic Repeated Dialing of Multiple Numbers without Confirmation

Not supported on the PSTN module.

This mode is useful where no trained personnel for automatic dialing with confirmation are available. The called user does not have to press any button. The two modes share a set of numbers, count of cycles, response to the busy tone, e.g., and so on.

The difference is that the no-confirmation mode recognizes the ringing tone and if the tone ends before the preset count of rings is exhausted, it means that the called user is off-hook and this is considered a successful connection.

The announcer cannot be controlled with buttons **1** to **5**.

Evaluation of Loud Automatic Dialing without Confirmation Situations

Situation	L8 Activity
Busy Tone	Hangs up in approx. 2 seconds and dials the next number.
Call or silence	Waits for a preset time (login timeout), then hangs up and dials the next number.
Call Ringtone	Waits for a preset time (login timeout), then hangs up and dials the next number.



WARNING

Make sure before using this mode that no VoiceMail box, fax machine or any other device that could answer the call before the preset rings is installed on any of the numbers to be called. This would lead to automatic dialing termination.

3 and 4. CPC (Antenna and KONE)

Used wherever the counterparty is equipped with the required SW. When the line is answered, a DTMF string is sent. The elevator identifies itself. The call is either switched to voice communication (alarm call) or confirmed automatically and terminated (checking call).

5. P100

Used wherever the counterparty is equipped with the required SW. When the line is answered, a DTMF character is sent. The elevator identifies itself. The call is either switched to voice communication (alarm call) or confirmed automatically and terminated (checking call).

6. DTMF Protocol Auto Detection (CPC/P100)

When the DTMF string is sent, the elevator identifies the protocol and responds accordingly.



WARNING

- **2N Lift8** may have troubles detecting DTMF characters and recognizing the protocol in places with a poor signal quality.
- If such troubles occur, we recommend that you change the CPC Antenna/P100 (3/5) settings.

7, 8, 9. CPC (Antenna a KONE), P100 2N ext

These protocols work like CPC in items 3 and 4 and P100 in item 5 above for alarm calls. The only difference is that the shaft number and audio unit type are transmitted too.

With 2N ext, error states OK can be transmitted too in operational calls (battery replaced, audio repaired, button fixed).

Elevator Blocking Function

The contact closes/opens whenever an alarm call cannot be set up.

Connect the contact to the relevant input of the control electronics of the elevator/group of elevators. The control electronics must ensure that the elevators in operation go down to the nearest station and the doors open after the contact opens.

Every CU and every splitter are equipped with the elevator blocking contact. Refer to Subs. [Central Unit \(p. 26\)](#) – Elevator Blocking Contact Connector.

The elevator blocking function will be enabled if:

- No number is defined in the **ALARM** memory – the elevator gets blocked immediately.
- A number to a non-existent machine room (intercom) is defined – the elevator gets blocked in 2 minutes.
- A PSTN number is defined but no module is inserted – the elevator gets blocked immediately.
- The external line (PSTN, VoIP) is not functional – the elevator gets blocked in 5 minutes.
- The dialtone is not detected – the elevator gets blocked in ca. 10 minutes (after the PSTN line test which does not detect the dialtone).
- No SIM (GSM/UMTS) is inserted – the elevator gets blocked in 5 minutes.
- There is no signal (GSM/UMTS) – the elevator gets blocked in 5 minutes (a very low signal does not cause blocking).
- The capacity of the device feeding battery so low that the internal buses (audio units) get disconnected – the elevator gets blocked when the internal bus gets disconnected.
- **2N Lift8** is off – the elevator gets blocked immediately.



CAUTION

- The PSTN line test is carried out every hour. If an error is detected, the line test is repeated every 2 minutes until the line is evaluated OK again.
- If parameter 902 is set to 0, the line test is not performed and the line is not blocked when the dial tone is not detected.

The elevator blocking function will be disabled if:

- The line works for 1 minute at least (PSTN, VoIP)
- A power supply is connected to recharge the battery









CAUTION

This function may be mandatory depending on the regulations applicable in the country at the time of installation.





Intercom Function

ALARM – Intercom Calls

1. Press the **ALARM**  button on any audio unit (except for the machine room set as the control room) to start the process. Upon the press, **2N Lift8** calls the pre-set machine room – control room audio unit.
2. Press **ALARM**  or  (for more than 2 s) to answer an incoming call.
3. When the call is answered by the operator, the **2N Lift8** system announcement will be played.
4. Then, voice connection with the calling audio unit is activated. Press 1 on the machine room audio unit keypad to confirm the received call manually. If confirmation by pickup is set (011–016=2), it is not necessary to confirm the call with DTMF1 (see [Control Room Instructions \(p. 170\)](#) for details).
5. The voice communication with the calling audio unit is then activated.
6. The call is time-limited (by the "Caution, the call is ending" message), but can be prolonged. Button 4 is used for this.
7. The call can be terminated by pressing **ALARM** , **5**  or .



CAUTION

- You cannot set up an alarm call to another control room from the machine room audio unit that is configured as the control room. The call is made to the audio unit that is the last to activate the alarm call. If no alarm call was activated on any audio unit, the machine room audio unit will not call any unit.
- Press **ALARM**  on the control room audio unit to set up a call to the audio unit that is the last to activate the **ALARM** function. After this connection is established, the call behaves as **TRIPHONIA**. It is therefore possible to terminate it using the button **TRIPHONIA**  on both speakers or using the button  (longer than 2 seconds) on the engine room loudspeaker.
- If a call is set up to a non-existent machine room audio unit, the Alarm call will not be set up (valid for settings #9, #0). If more numbers than one are pre-programmed, the non-existent audio unit is skipped.
- The call can be terminated during ringing or even after picking up before confirmation (if auto dial with DTMF 1 confirmation is set). This is done by pressing  (for more than 2 seconds). The call is then routed to the next number in memory **ALARM**.

Number Setting for Machine Room – Control Room Audio Unit Calls

Enter # before the shaft number to set the machine room number.

For example, 011 – #8 means that a call to the machine room audio unit in the shaft of elevator 8 is set in **ALARM** button memory 1.

Setting options:

1. Service Tool – enter # and the shaft number into parameters 011–016.

Code ▼	Name	Value
^ Alarm call		
011	Set 1 - ALARM button memory 1	#8

2. Enter the programming mode via the voice menu (incoming call or machine room audio unit) and enter the shaft number into the ALARM memory (011–016). Then choose parameter 017 (refer to the Table of Parameters) and add the required character (#) to one of the button memories.



CAUTION

- Configure the Alarm-Intercom connection for calls to the machine room audio unit of any shaft (1–8).
- Identically, configure the machine room – control room connection for **ALARM** set 2.
- Make sure that the control room audio unit is of the machine room type.
- You can use confirmation mode 1 or 2 for calling to a machine room audio unit. With the other options (3–9), the call is processed as if 1 was selected.



NOTE

- It is possible to combine calling to the machine room (control room) audio unit with calling via the PSTN, GSM, UMTS and VoIP networks (depending on the module used).
- To set up a checking call to a machine room audio unit, you can set the number as described in the Alarm – Intercom subsection above.

System Completeness Check and Audio Unit Audio Test

Features

The system only monitors the cabin and Fireman audio units that have been set (they were connected during setup with the **RESET** button). Newly added audio units are not monitored by the system. Use the **RESET** button again to make the system monitor all the audio units added later to the system.

Such audio units are displayed in the Supervision – Added Units menu in the 2N Service Tool. The 2N Service Tool only monitors the completeness of the cabin audio units, the Fireman units and the MEEF evacuation audio unit).

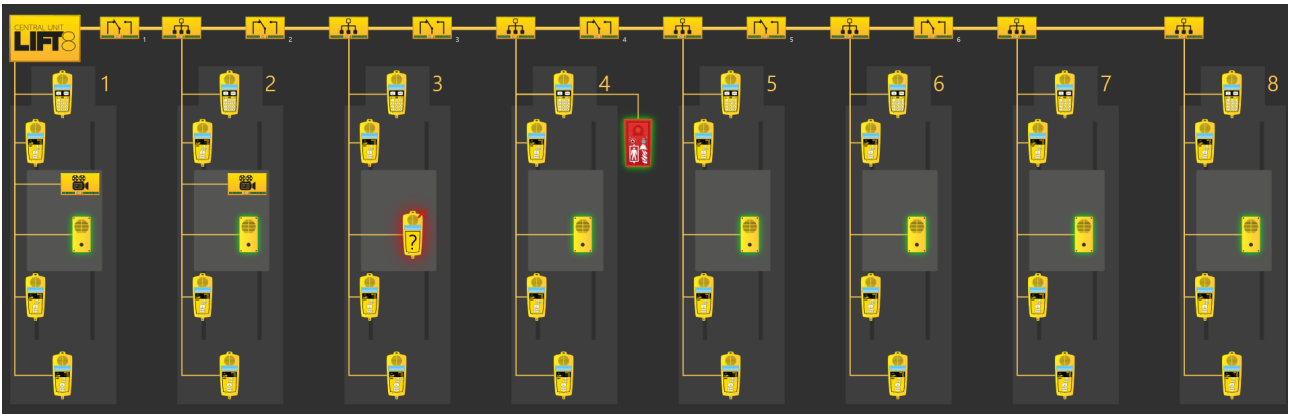

Display of Audio Units to Be Checked in Service Tool:

- The connected cabin and Fireman audio units that are checked and OK are flashing green.
- The defective/missing audio units are flashing red (see the cabin in shaft 3).

If an audio unit is missing in the system, no checking call is made and the INTERNAL BUS LED red light is on.



NOTE

If no audio units, splitters, etc. are connected in the **2N Lift8** system, the INTERNAL BUS LED red light is flashing even if no system completeness check is being performed.

System Completeness Check Enable

Use the **RESET** button to set the function.

Press and hold the button until all the LEDs light up red. Then release the button and wait until the INTERNAL BUS LED flashes yellow. Now press the button quickly. The system will check all the audio units (cabin, Fireman) from now on for proper connection and function.

Audio Unit Audio Test

Use parameter 993 to enable the audio test for audio units. The selected audio units (cabin, Fireman) are tested after a checking call. If all the audio units are OK, the next checking call will be made. If an audio error is detected in one or more audio units, the next checking call will not be made.

The INTERNAL BUS LED flashes red to indicate an audio test failure.



CAUTION

The audio unit audio test is active only if the system completeness check is enabled and checking calls are active.



NOTE

- An audio test is considered unsuccessful if it fails three times.
- The test is carried out three times in 1-hour intervals.
- Repeated tests are only made for the audio units that failed the previous audio tests.
- All the checked audio units are re-checked after a checking call.

Event after Audio Error

A faulty audio test can be indicated by an event generation. Use the Service Tool Events – Audio Error menu for configuration. When an audio test error is detected, any of the following events is executed.

The following options are available:

- I/O module output activation
- I/O module output deactivation
- Send SMS – set the phone number and text
- Send system SMS – set the phone number
- Operational call – the call is set up to the number in par 081-088 (operational call), this type of call uses the CPC Antenna, CPC KONE or P100 protocol for transmission.

An operational call for this event is only possible if the CPC Antenna 2N ext., CPC KONE 2N ext. or P100 2N Ext. protocol is set in parameters 181-186. Make sure that CPC KONE or P100 is set in the Control Panel for the CPC KONE 2N Ext and P100 2N Ext protocols. Make sure that CPC Antenna 2N Ext is set in the Control Panel for the CPC Antenna 2N Ext protocol.



CAUTION

The event is not executed until the audio test fails three times.

Another event can be executed if the audio test results are OK. The events related to an audio error (I/O module output activation/deactivation, send SMS or operational call) can be executed. Set the parameters via the Service Tool again (Configuration – Events – Stuck button)

System Completeness Check Disable

1. To cancel the system completeness check, you must disconnect all the audio units. The best way to do this is to disconnect the main bus and the audio unit bus directly on the CU. It takes the CU some time (several tens of seconds) to find out that all the units have been disconnected. Therefore, use the Service Tool to check whether all the units have logged out.
2. Then press and hold **RESET** until all the LEDs light up red.
3. Release the **RESET** button and wait until the INTERNAL BUS LED starts flashing yellow.
4. Now press the button quickly. Now the system checks no audio units.

Parameter 990

You can set the operational call when the event is triggered using parameter 990. Refer to [Subs. System Configuration \(p. 123\)](#) for details.



CAUTION

If you set the operational call via parameter 990 and Events menu (script), the call will be set up twice.

ALARM Button Test

This function informs that the ALARM button got stuck in the elevator cabin.

Set the timeout in seconds after which the button shall be considered jammed in parameter 969 (**ALARM** button test). Then, the event defined via the 2N Service Tool (Configuration – Events – Stuck Button) will be executed.

The following events are available:

- I/O module output activation
- I/O module output deactivation
- Send SMS – set the phone number and text
- Send system SMS – set the phone number
- Operational call – the call is set up to the number in par 081-088 (operational call), this type of call uses the CPC Antenna, CPC KONE or P100 protocol for transmission.

An operational call for this event is only possible if the CPC Antenna 2N ext., CPC KONE 2N ext. or P100 2N Ext. protocol is set in parameters 181-186. Make sure that CPC KONE or P100 is set in the Control Panel for the CPC KONE 2N Ext and P100 2N Ext protocols. Make sure that CPC Antenna 2N Ext is set in the Control Panel for the CPC Antenna 2N Ext protocol.



CAUTION

- Multiple events can be set up (output activation + operational call, e.g.).
- SMS can be sent only if the LTE module is installed.
- If you set the operational call option and CPC/P100 2N ext confirmation, the audio unit type (cabin 1 or 2) and shaft number is displayed for the rescue process (if the call is received via the 2N Lift8 server).
- Set the I/O module activation/deactivation timeout to 1 s at least. If you set 0, the activation/deactivation will not work.

The next event can be executed after the button is fixed. The events related to a stuck button (I/O module output activation/deactivation, send an SMS or make an operational call) can be executed. Set the parameters via the Service Tool again (Configuration – Events – Stuck Button)



CAUTION

- We recommend that you set a rather long interval in parameter 969 to avoid unintentional event generation.
- Recommended value: 300 s

Parameter 990

You can set the operational call when the event is triggered using parameter 990. Refer to [Subs.System Configuration \(p. 123\)](#) for details.



CAUTION

If you set the operational call via parameter 990 and Events menu (script), the call will be set up twice.

Rescue Process Activation / End

Rescue Process Activation

The rescue process is activated by setting parameter 966, which also determines when the release mode is terminated. If an alarm call is set up, the yellow LED keeps shining on the audio unit after the call end. This indicates the rescue process activation.

Rescue Process End

The method of termination of the release process is set by parameter 966. The release process can be terminated in two ways:

- Call **2N Lift8** (9 for administration – 2 for rescue end – select the shaft – enter the password – press *).
- Set the I/O module input (via 2N Service Tool – I/O modules – create the "Rescue end" action and assign it to one of the I/O modules).

When the rescue process has been ended, the active audio unit will report: "Rescue process ended".

Event after Rescue End

An event can be made when the rescue process has been ended:

- I/O module output activation
- I/O module output deactivation
- Send SMS – set the phone number and text
- Send system SMS – set the phone number
- Operational call – the call is set up to the number in par 081-088 (operational call), this type of call uses the CPC Antenna, CPC KONE or P100 protocol for transmission.

An operational call for this event is only possible if the CPC Antenna 2N ext., CPC KONE 2N ext. or P100 2N Ext. protocol is set in parameters 181-186. Make sure that CPC KONE or P100 is set in the Control Panel for the CPC KONE 2N Ext and P100 2N Ext protocols. Make sure that CPC Antenna 2N Ext is set in the Control Panel for the CPC Antenna 2N Ext protocol.

Use the 2N Service Tool Events menu (Events – Rescue End) for configuration.



CAUTION

- Multiple events can be set up (output activation + operational call, e.g.).
- SMS can be sent only if the LTE module is installed.
- If you set the operational call option and CPC/P100 2N ext confirmation, the audio unit type (cabin 1 or 2) and shaft number is displayed for the rescue process (if the call is received via the 2N Lift8 server).

Parameter 990

You can set the operational call when the event is triggered using parameter 990. Refer to Subs.[System Configuration](#) (p. 123) for details.



CAUTION

If you set the operational call via parameter 990 and Events menu (script), the call will be set up twice.

Battery Replacement

2N Lift8 monitors the rechargeable battery state. If the battery capacity is low or the batteries are older than 2 years, the red Power/battery LED will start flashing on the CU. The “Replace battery” event can be executed in this state to inform the user of the battery replacement need.



NOTE

The device continuously monitors the status of its battery. When the battery capacity drops to the level that allows 1 hour of operation and 15 minutes of calling, the device automatically sends an information SMS message.

The following options are available:

- I/O module output activation
- I/O module output deactivation
- Send SMS – set the phone number and text
- Send system SMS – set the phone number
- Operational call – the call is set up to the number in par 081-088 (operational call), this type of call uses the CPC Antenna, CPC KONE or P100 protocol for transmission.

An operational call for this event is only possible if the CPC Antenna 2N ext., CPC KONE 2N ext. or P100 2N Ext. protocol is set in parameters 181-186. Make sure that CPC KONE or P100 is set in the Control Panel for the CPC KONE 2N Ext and P100 2N Ext protocols. Make sure that CPC Antenna 2N Ext is set in the Control Panel for the CPC Antenna 2N Ext protocol.



CAUTION

SMS can be sent only if the LTE module is installed.

It is also possible to generate an event when the status is *Battery replaced*. The events related to battery replacement (I/O module output activation/deactivation, send SMS or operational call) can be executed. Set the parameters via the Service Tool again (Configuration – Events – Battery Replaced).

Parameter 990

You can set the operational call when the event is triggered using parameter 990. Refer to Subs.[System Configuration \(p. 123\)](#) for details.



CAUTION

If you set the operational call via parameter 990 and Events menu (script), the call will be set up twice.

CPC and P100 Protocols

CPC

There are two CPC protocols: KONE and Antenna. These protocols can include 2N Ext, which completes the DATA (error) information with the shaft number and audio unit type.

The data message consists of:

Command – Call type – DATA – ID (974) – Axx (for 2N Ext only)

CPC KONE 2N Ext

Call Type	Command	Call Type	Data	ID (974)	2N Ext
Alarm	04	10	000000000000	parameter 974	Axx
Alarm 2	04	10	000000000000	parameter 974	Axx
Checking Call	04	21	000000000000	parameter 974	
Rescue process ended	04	84	000000000000	parameter 974	Ax
Button stuck	04	90	000000000000	parameter 974	Axx
Button fixed	04	90	000000000001	parameter 974	Axx

Call Type	Command	Call Type	Data	ID (974)	2N Ext
Replace battery	04	31	1510070000000	parameter 974	
Battery replaced	04	31	1510070000001	parameter 974	
Audio error	04	91	0000000000000	parameter 974	Axx
Audio repaired	04	91	0000000000001	parameter 974	Axx

Note Axx:

A – shaft and audio unit extension

Xx – shaft number

xX – audio unit type (0 – cabin, 1 – machine room, 2 – shaft, 3 – cabin roof, 4 – cabin bottom, 5 – cabin 2, 6 – cabin 2 roof, 7 – cabin 2 bottom, 8 – fireman)



NOTICE

This is only a part of the data message. It does not contain the beginning, checksum and end.

0490000000000000187654321A50 – Button fixed, identification number (parameter 974) 87654321, shaft 5, cabin audio unit



CAUTION

- The Button fixed, Battery replaced and Audio repaired information is only transmitted via the 2N Ext protocol.
- If the 2N Ext mode is not set, the operational call cannot be established.

CPC Antenna 2N Ext

Call Type	Command	Call Type	Data	ID (974)	2N Ext
Alarm	04	27	00000	parameter 974	Axx
Alarm 2	04	27	00000	parameter 974	Axx

Communication in Elevator Shafts

Call Type	Command	Call Type	Data	ID (974)	2N Ext
Checking Call	04	26	00000	parameter 974	
Rescue process ended	04	84	00000	parameter 974	Ax
Button stuck	04	90	00000	parameter 974	Axx
Button fixed	04	90	00001	parameter 974	Axx
Replace battery	04	17	00000	parameter 974	
Battery replaced	04	17	00001	parameter 974	
Audio error	04	91	00000	parameter 974	Axx
Audio repaired	04	91	00001	parameter 974	Axx

Note Axx:

A – shaft and audio unit extension

Xx – shaft number

xX – audio unit type (0 – cabin, 1 – machine room, 2 – shaft, 3 – cabin roof, 4 – cabin bottom, 5 – cabin 2, 6 – cabin 2 roof, 7 – cabin 2 bottom, 8 – fireman)



NOTICE

This is only a part of the data message. It does not contain the beginning, checksum and end.

04910000087654321A45 – Audio error, identification number (parameter 974) 87654321, shaft 4, cabin 2 audio unit



CAUTION

- The Button fixed, Battery replaced and Audio repaired information is only transmitted via the 2N Ext protocol.
- If the 2N Ext mode is not set, the operational call cannot be established.

P100

This protocol can also include 2N Ext, which completes the DATA (error) information with the shaft number and audio unit type.

The data message consists of:

Call type – ID (974) – DATA – Axx (for 2N Ext only)

P100

Call Type	Call Type	ID (974)	DATA	2N Ext
Alarm	1	parameter 974		Axx
Alarm 2	1	parameter 974		Axx
Checking Call	3	parameter 974		
Rescue process ended	2	parameter 974	500	Ax
Button stuck	2	parameter 974	800	Axx
Button fixed	2	parameter 974	801	Axx
Replace battery	2	parameter 974	100	
Battery replaced	2	parameter 974	101	
Audio error	2	parameter 974	200	Axx
Audio repaired	2	parameter 974	201	Axx

Note Axx:

A – shaft and audio unit extension

Xx – shaft number

xX – audio unit type (0 – cabin, 1 – machine room, 2 – shaft, 3 – cabin roof, 4 – cabin bottom, 5 – cabin 2, 6 – cabin 2 roof, 7 – cabin 2 bottom, 8 – fireman)



NOTICE

This is only a part of the data message. It does not contain the beginning, checksum and end.

287654321500A3 – Rescue process ended, identification number (parameter 974)
87654321, shaft 3



CAUTION

- The Button fixed, Battery replaced and Audio repaired information is only transmitted via the 2N Ext protocol.
- If the 2N Ext mode is not set, the operational call cannot be established.

Evacuation Mode

In the Evacuation mode, **2N Lift8** (L8) ensures a reliable communication with the evacuation elevator floors, which is crucial for a safe and rapid evacuation of persons in emergency.

The system is controlled by the Central Unit (CU), which provides telecommunication connection of the audio units with an IP phone. Thus, a responsible and duly trained person can communicate with the evacuees on all the floors via an IP phone, ensuring a successful evacuation process.

The floor audio units are connected to a bus (pair of wires) and to the CU via a splitter. The CU is equipped with an internal splitter of its own. Up to 7 additional splitters can be connected to the CU. Up to 8 audio units can be connected to each splitter. Thus, the **2N Lift8** system can serve up to 64 audio units/floors.

The audio units are numbered 01 to 64. 8 positions are allocated for each splitter, see the table below:

Splitter address	Audio unit numbers
Splitter 1 (CU internal splitter)	01 to 08
Splitter 2	09 to 16
Splitter 3	17 to 24
Splitter 4	25 to 32
Splitter 5	33 to 40
Splitter 6	41 to 48
Splitter 7	49 to 56
Splitter 8	57 to 64

Mode Activation

To switch Lift8 into the Evacuation mode, set parameter 996 to 1 (enabled). Setting parameters is described in Subs. [System Configuration \(p. 123\)](#).

System diagram

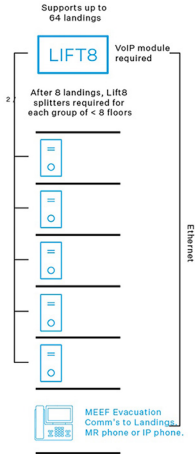

Main bus

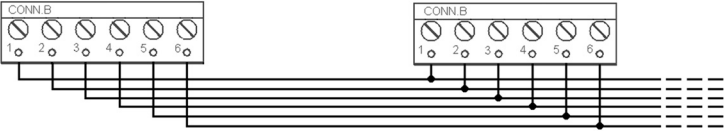

Bus (audio units)

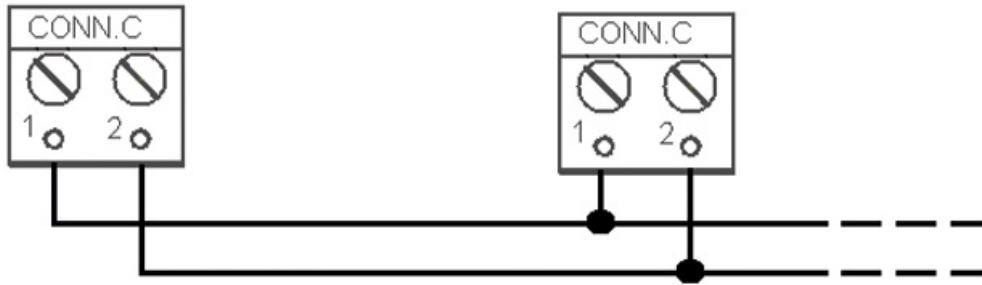

IP Phone Connection

The **2N Lift8** system can be interconnected with any IP phone. This manual focuses on the connection settings for the 2N IP Phone D7A, which has been designed specifically for the Evacuation mode.

EVAC uses Direct Sip Call without registration.



CAUTION

2N Lift8 uses the UDP protocol in the Direct Call mode. The D7A device must also be set to the UDP mode.

2N Lift8 Service Tool Settings

1. Go to Configuration > Parameters.
2. Click the \oplus icon under the table to create a new list.
3. Expand the Network Setting tab:
 - a. Disable the dynamic IP address allocation by the DHCP server (1100=0) in parameter 1100.
 - b. Set the 2N Lift8 Central Unit static address in parameters 1101 and 1102.
 - c. Set the 2N IP Phone D7A IP address as the default gateway (parameter 1103).
 - d. Set parameter 111 to 2 to enable call connection without confirmation.

Evacuation Mode

- Set the 2N IP Phone D7A IP address in parameter 011. This parameter defines where the call from the evacuation audio units shall be routed.
- Click ⓘ under the table to upload the changes in the device.



NOTE

If **2N Lift8** has already been configured and you want to make changes in the existing configuration, do not create a new set of parameters but read the data from the device.

Audio Unit Name Setting

The audio units are numbered 01 to 64. 8 positions are allocated for each splitter. Typically, this audio unit numbering does not correspond to the floor numbers in the building and so it is well advised to name the audio units.

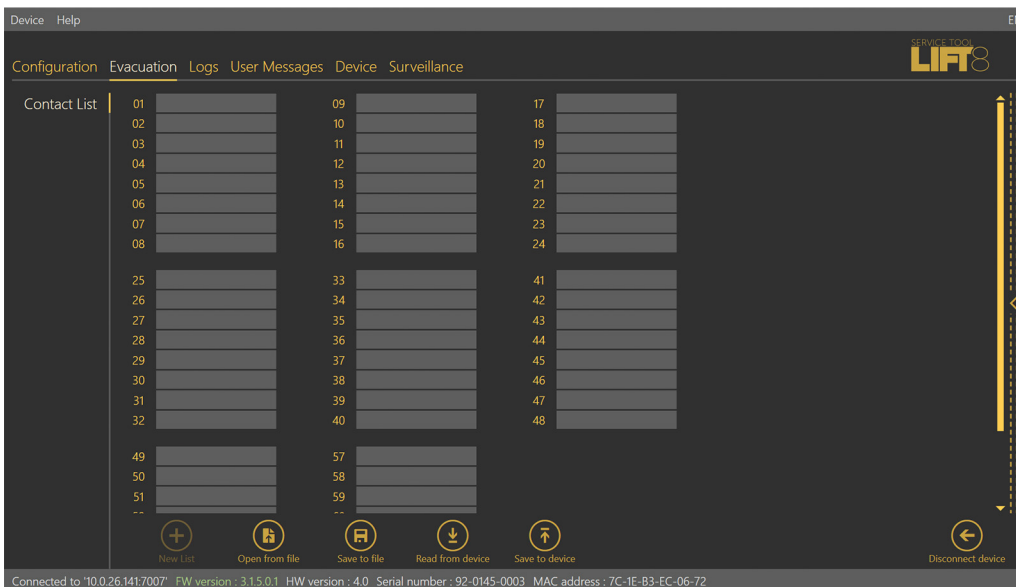

- Go to Evacuation > Contact List.
- Name the audio units according to their actual locations.
- Click ⓘ under the table to upload the changes in the device.



TIP

You can save the list as an XML file and upload it into the IP phone directory later.

**NOTE**

If Lift8 has already been configured and you want to make changes in the existing configuration, do not create a new set of parameters but read the data from the device.

2N IP Phone D7A Settings

1. Set a static IP address for the phone in the phone menu: Settings > Advanced Settings (default password: admin) > Network > WAN Port > IPv4.
2. Enter your phone the IP address into your web browser. The current IP address can always be found in the phone menu: Settings > State > Network > Ipv4 State.
3. Enter the login data. The default user name is “admin” and the password is “admin”.
4. Go to Account > Register.
5. Set Server Host to the Lift8 CU IP address in SIP Server 1.

SIP Server 1

Server Host

10.0.26.87

Port

5060

Přenos

UDP

6. Save your changes by clicking **Confirm**.

Directory Settings

#	Name	Office Number	Mobile Number	Other Number	All Contacts	Operation
1	Lift8 - FI -1 Garage	2			All Contacts	✎ ☰
2	Lift8 - FI -2 Garage	1			All Contacts	✎ ☰
3	Lift8 - FI oor 1	4			All Contacts	✎ ☰
4	Lift8 - FI oor 10	13			All Contacts	✎ ☰
5	Lift8 - FI oor 11	14			All Contacts	✎ ☰
6	Lift8 - FI oor 12	15			All Contacts	✎ ☰
7	Lift8 - FI oor 13	16			All Contacts	✎ ☰
8	Lift8 - FI oor 14	17			All Contacts	✎ ☰
9	Lift8 - FI oor 15	18			All Contacts	✎ ☰
10	Lift8 - FI oor 16	19			All Contacts	✎ ☰

1. Go to Contacts > Local Directory.

2. Create a new contact for each floor:
 - Name the contact in such a manner that it is obvious on which floor it is located.
 - The office number is the audio unit number (01–64) Caution

 **CAUTION**
 Make sure that two-digit numbering (01–09) is used for a correct display of the audio unit name on the IP phone.

- Select Auto in the account selection.
3. Create a contact with office number 99. Dialing this number will send an evacuation message to all the audio units in the system.

 **TIP**
 You can export the contact list as an XML file and upload it into the contact list in **2N Lift8 Service Tool** later.

Control Room Instructions



2N IP Phone – Control Room

The phone should only be operated by a responsible and duly trained evacuation coordinator.

The **2N Lift8** system can be interconnected with any IP phone. This manual focuses on the connection settings for the 2N IP Phone D7A, which has been designed specifically for the Evacuation mode.

Dialing Number

 **CAUTION**
 The numbers of the audio units have two digits. Dial 01–09 for the first 9 audio units.

Using the handset:	Using the speakerphone:	Using a headset:	On the display:
<ol style="list-style-type: none"> 1. Pick up the handset. 2. Dial a number and press Call. 	<ol style="list-style-type: none"> 1. Press  in the idle state. 2. Dial a number and press Call. 	<ol style="list-style-type: none"> 1. Connect the headset and press  to activate the headset call. 2. Dial a number and press Call. 	<ol style="list-style-type: none"> 1. Click the phone book icon . 2. Click the contact to be dialed.

Dialing Number

1. Enter an asterisk followed by the audio unit phone number *01–64. The phone number has always two digits. Example: press *05 to call audio unit 5.

**CAUTION**

The call hold button works just like on a normal phone – the call is put on hold. However, if you want to make a new call to another floor or audio unit, do not use the button. If you press it, you will not be able to dial another call using the code (*xx).

Dialing Number 99 – Evacuation Report

Dialing number 99 sends an evacuation message to all the audio units connected. After the successive message playback request is sent, the call will be terminated automatically.

**TIP**

To send an evacuation report while making a call with an audio unit, enter *99 on your phone keypad.

Set the count of message repetitions in parameter 997 (the default value is 1).

**NOTE**

An alarm call dialed on an evacuation audio unit always takes precedence over the evacuation message. If the evacuation audio unit button is pressed during the evacuation message, a call will be set up and the message will not be played back on the audio unit concerned.

Call Answering**Using the handset:**

Pick up the handset.

This option is only available if parameter 111 is set to 2 on

L8. If parameter 111 is set to the default value, press **1** on the keypad for call confirmation.

Using the speakerphone:

Press the  button.

Using a headset:

Press the  button.



Incoming calls are queued in the sequence in which they were made on the floors. The second call will not ring until the first call is ended.

End of Call

Using the handset:	Using the speakerphone:	Using a headset:
Press the Call end button or hang up the handset.	Press  or End Call.	Press End Call button.



NOTE

The modes can also be switched during calls by pressing   or by picking the handset.

Redial – Dial the Last Called Number

In the Idle mode, press  twice to redial the last called number.

User Instructions – Floor Audio Unit

The floor audio unit is intended for the lay public operation. It is advisable to place the user instructions near the audio unit, including, for example, the information to be communicated to the control room by the evacuees: count of persons to be evacuated, health conditions of the persons, etc.

Press the button (for more than 3 seconds) to set up a call to the control room. Once the call is received by the control room, the connection is established. The call is hands-free and cannot be terminated from the audio unit.

The call setup is signaled by the Fireman audio unit LED.

LED Indicators

yellow LED (on)	The call is addressed, waiting for reception.
green LED + yellow LED (on)	The call is active, connection with the control room has been established.

Service Tool

The Service Tool application provides secure configuration of the **2N Lift8** system via a PC.

Refer to the **2N Lift8** product section at 2N TELEKOMUNIKACE websites (Support > Download Center) for the latest FW version.

The Service Tool version 3.0 and higher also support the administration of the **2N Lift8** models equipped with hardware that is not upgradable to higher versions.

Installation and Login

System Requirements and Preparation

Recommended hardware requirements

OS	Microsoft Windows 11
.....	
CPU	Equivalent Intel Quad Core i7 3.4 GHz
.....	
RAM	8 GB
.....	
HDD	500 GB
.....	
LAN	100 Mb/s Ethernet (LAN)
.....	
Other	<ul style="list-style-type: none"> • Dedicated Sound card (User message recording) • Dedicated Graphics card



WARNING

- There is an installer change in version 2.2.0 and higher. The installer is unable to remove the original application versions (up to 2.1.x) correctly and an installation error may occur. To avoid this, remove the original applications manually if you use versions lower than 2.2.0.
- Finally, you will be asked whether you really want to delete the existing configuration files. If you click NO, your configuration will be preserved.

**TIP**

Some Windows Vista versions may have problems while detecting a connected device. If a system message keeps announcing you that the device has not been recognized and the driver installation has failed, follow the instructions below to solve the situation manually:

1. Open the device manager and find the ill-detected hardware (marked with a yellow triangle).
2. Display a menu for this device with the right mouse click and select Update Driver.
3. Click the option to find the driver in the PC.
4. Click the option to select a driver from a list and select a **2N Lift8** model instead of Complex USB device.
 - a. If there is no **2N Lift8** selection, go one step back.
 - b. Here enter the path to the driver file on the local disk and get the driver installed.
 - c. The typical path is C:\Program Files (x86)\2N ... \Service Tool\inf
5. At this point, the driver will start working, and if you connect the Central Unit to the same PC USB port next time, it will be detected correctly.

**WARNING**

- Make sure that the USB port driver for 2N Lift8 Central Unit is properly installed on the logging-in PC. If not, the device will not be recognized and you will be unable to connect to it.
- If the Incompatible .NET version message is displayed upon the installer launch, download the current .NETFX4.0 redistribution from the 2N TELEKOMUNIKACE websites or use the link [here](#).
- Minimum operating system requirements: Windows Vista, Windows 7, Windows 8.
- The **2N Lift8** Service Tool installation requires 500 MB of free disk space at least.

**TIP**

The wizard will install the USB port driver if unavailable to identify the Central Unit connected.

Standard Installation (Wizard)

After the application is launched, the installation program will scan your PC. If it finds a different version of the 2N Lift8 Service Tool installed, it will perform a check. If the version found is the same as the version you are currently installing, you will be notified to remove the version already installed. To reinstall or reconfigure it, you must remove the existing version of the product. Use the system control panel to add or remove programs. If the versions are not identical, the original version will be uninstalled and a new application version will be installed. Then you will also be asked whether the configuration files should be removed or the whole application with a new, empty database should be installed.

Now the 2N Lift8 Service Tool Setup Wizard has been launched. Follow the wizard instructions. Then select the installation location for the 2N Lift8 Service Tool. C:\Program Files (x86)\2N TELEKOMUNIKACE\2N Lift8\ is used by default. The following is a request for cooperation on software improvements. The application asks you for permission to send system data and software usage reports to 2N TELEKOMUNIKACE a.s. This information helps 2N TELEKOMUNIKACE a.s.

improve the software quality, reliability and performance. No confidential data shall be sent. You can participate in this voluntarily and cancel your statistic data deliveries any time. Confirm or decline this cooperation and click Next to continue.

Now the wizard is ready to install the 2N Lift8 Service Tool. Confirm user account administration notification to the Windows system if necessary. Another Start item and the application shortcut icon will be added automatically. Once installed, the application will start automatically.

Installation via Command Line

Alternatively, use the command line for installation. Select the installer file in the command row and define the manner and location parameters. See below for command explanation.

Command	Description
<code>/VERYSILENT</code>	Installation runs on the background, no installer is open to the user.
<code>/DIR="C:\..."</code>	Set the installation location
<code>/NO-DRIVER=1</code>	No driver is installed for 2N Lift8
<code>/LOG=file_name.txt</code>	No driver is installed for 2N Lift8

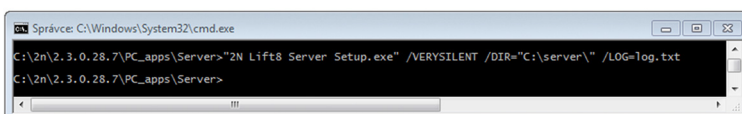

```

Správce: C:\Windows\System32\cmd.exe
C:\2n\2.3.0.28.7\PC_apps\Server>"2N Lift8 Server Setup.exe" /VERYSILENT /DIR="C:\server\" /LOG=log.txt
C:\2n\2.3.0.28.7\PC_apps\Server>

```

Application Installation Command



CAUTION

Make sure that the command row is started by admin. If it is started by a user, the editor authenticating window will pop up.

Now the 2N Lift8 Service Tool is ready for use. Click on the shortcut item on the desktop (see the figure below) or select the Start item to start the application.



2N Lift8 Service Tool Icon



CAUTION

You need authorization to write into the folder where the application is stored to make the application work properly. Unless specified otherwise during installation, the application is located at C:\Program Files (x86)\2N TELEKOMUNIKACE by default.

Login

After the launch, you will be in the basic screen and Configuration / Parameters menu. Here an offline table of parameters can be prepared for you to export the data or view the diagnostic packages.

Click Connect Device to get connected to the CU. This gets you into the Connect to Device menu.

1. Choose your login method. Select the login mode: TCP or USB. TCP is selected by default.
2. If you choose the Advanced settings, the list of all available connections to the 2N Lift8 Central Unit will be displayed to the left in a clearly arranged tree structure. If you have installed the application for the first time, the default connection will be created automatically. This connection cannot be removed. Click New Server and New Group to create a tree structure of your own. The settings are saved by a successful CU connection. Select a connection and click Delete selected to remove a connection. Be sure to complete the connection parameters correctly to make the CU connection successful.
3. Enter the connection name and the 2N Lift8 Central Unit or 2N Lift8 Server IP address in the public network. Use the DNS terms if available.
4. Fill in the CU listening port (7007) or the Server port (7008). Contact your LAN administrator to verify the settings.
5. Other parameters are Username and Password. Fill in the correct details of your Central Unit or Server here. The default password is 2n.
6. The possible settings are shown in the figure. Select the connection from the CU list and press Connect or double click the selected CU with the left mouse button. The application will log you in to the 2N Lift8 Central Unit. Take analogous steps to connect to the 2N Lift8 Server. However, you cannot use double click in this case. Just select a connection and click Connect to Server.

Service Tool

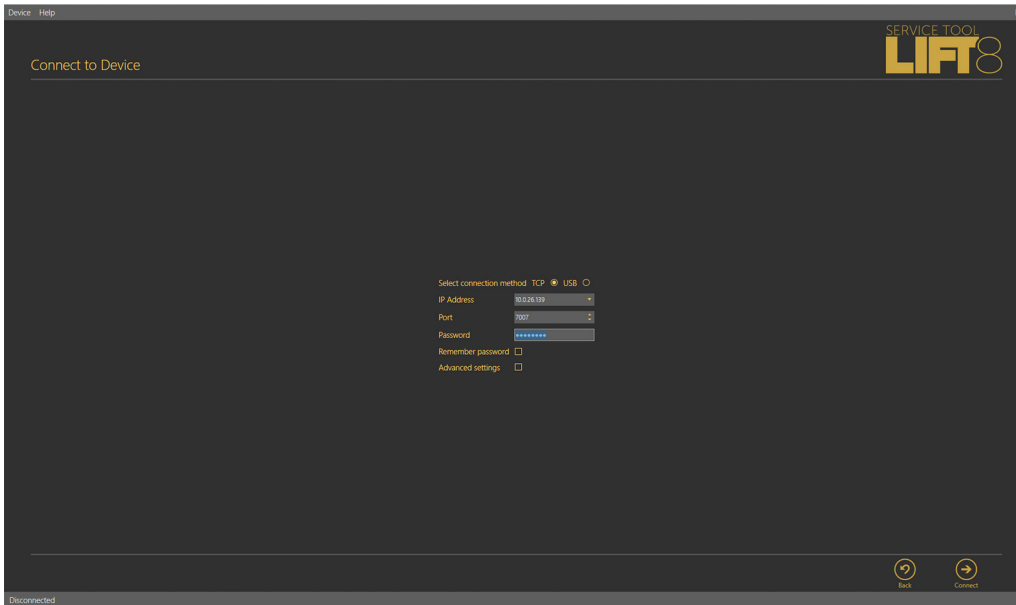

Application Window

Once connected to the server, you can log in and go to the list of 2N Lift8 Central Units connected to the server. The 2N Lift8 Central Unit list as configured on the given server will be displayed. Including the following activity symbols: The red chain under the elevator signals the Disconnected state of the data connection between the Server and the Central Unit. The blue chain under the elevator signals the Connection Established state of the data connection between the Server and the Central Unit. This indicates that it is now possible to get connected to the Central Unit. The green chain under the elevator signals the File Transmission state of the data connection between the Server and the Central Unit. Click the Connect button or double click the selected unit to get connected to the CU.

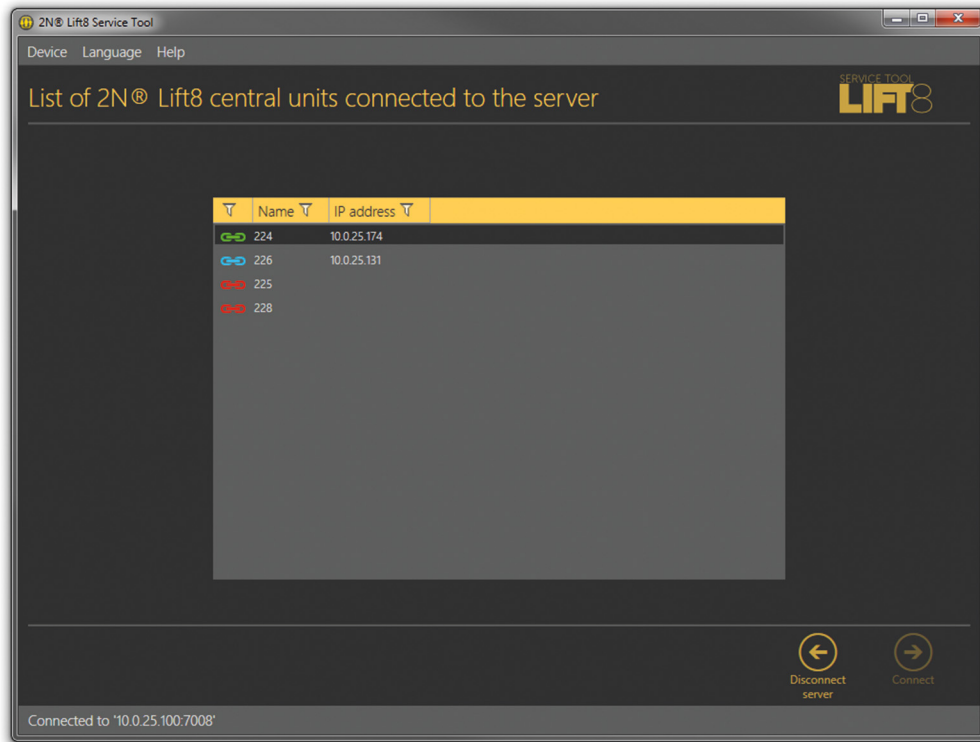

List of Central Units Connected to Server

If you use a USB cable for CU connection, select the USB connection type. The screen will change and the login name and password will only be visible. Enter the correct values. Refer to the text below for the default values. Now connect the CU to the PC and click Connect. The 2N Lift8 Service Tool automatically finds the connected CU on the PC and starts downloading parameters and logs. Having completing the download, the 2N Lift8 Service Tool is ready to work.



CAUTION

- Default values for CU connection:
 - TCP
 - Password: 2n
 - Port: 7007
 - USB
 - Password: 2n

Introduction to Application

In this subsection, we will show you the application menu layout and basic controls. The application is divided into three menu levels. The first screen upon start includes Configuration / Parameters / Basic. See the figure below. It displays all of the three menu levels. The horizontal Main menu (Configuration and Logs) helps you select whether to configure the **2N Lift8** system or supervise the history of logged events. The vertical menus (Parameters, Cameras, I/O Modules) help you select the area to be administered. The third menu level, if meaningful, gets displayed horizontally to the right. It includes a list of parameter setting forms.

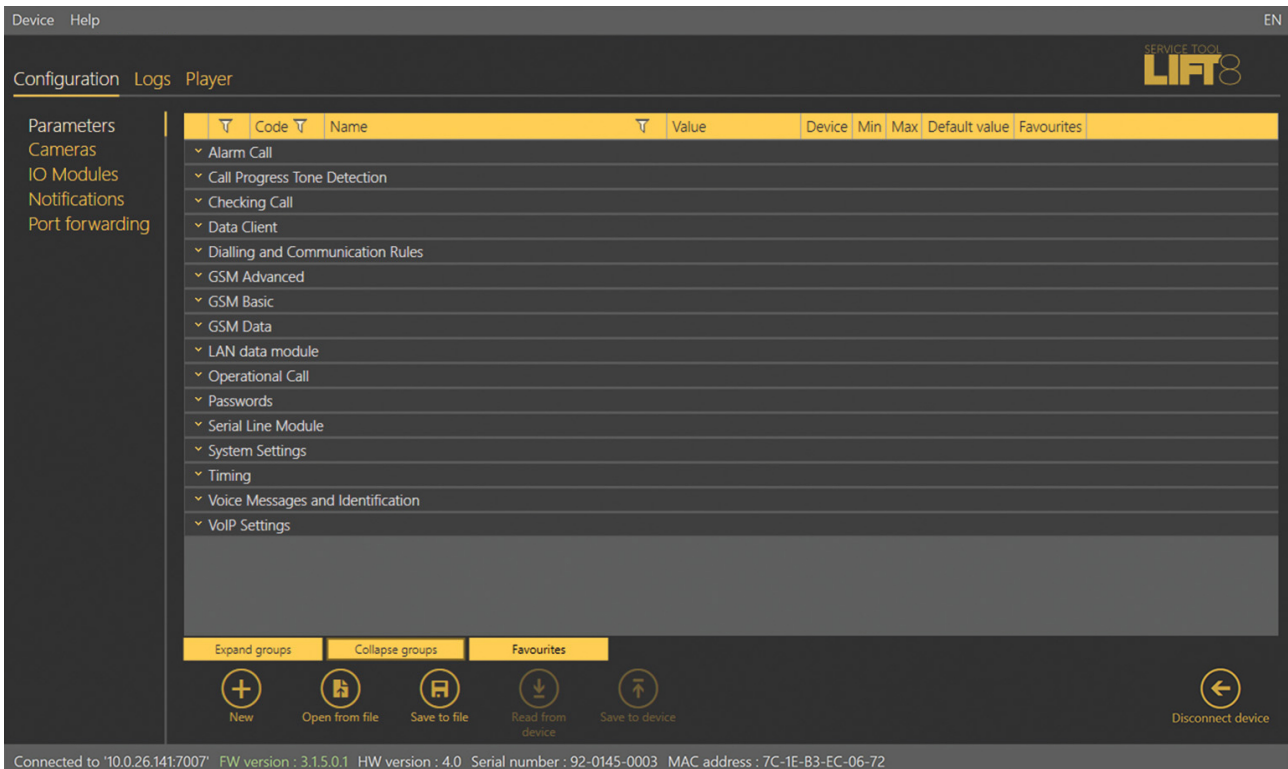

2N Lift8 Service Tool Window

The Main menu contains three pop-up menus. The Device menu helps you disconnect from/connect to the CU and quit the program. In its setting submenu, you will find the Statistics window. Here you can help the manufacturer improve the software. With your consent, you allow the software to send system data and use surveys to 2N TELEKOMUNIKACE a.s. The company uses this information, in accordance with the applicable laws, to improve the quality, reliability and performance of the software. You can participate in this voluntarily and cancel your statistic data deliveries any time. The Diagnostic package submenu helps you download a package including information relevant for troubleshooting. It includes the device state, bus operations and control room communication. Log in to the CU to get access to this package. Select the language mutation in the Language menu. CZ, DE, EN, ES, FR and IT are available so far. The Help menu provides a link to the latest manual version and information on the supplier. You will always be warned before logout or quitting against potential data loss.

You will also be warned against data loss before loading a new configuration and overwriting the current set of parameters. The new configuration and overwriting the current values will not be performed until you confirm this warning. This avoids any unintentional loss of unsaved parameters.



NOTE

Changing the language will require a restart of the application. Without it, the change will only be made upon the next startup.

The Status line displays connection information. From the left: 'Connected to' includes the name of the server to which you are currently connected, This corresponds to the name in the tree structure. The server name is followed by its IP address and port. In case you are connecting via USB, here is the name of the COM port on your PC. 'Current user' displays the currently logged in user, 'FW version' specifies the current CU FW version. 'Serial number' gives the CU serial number.

After logging in to CU, the Current Device Status menu is present throughout the application on the right side. This window can be hidden or re-displayed any time using the arrow in the left-hand upper corner.

Service Tool

This information panel can be seen in the figure below. The information is arranged in associated groups according to the meaning. The first part is Connection Properties. Here you can find the Line Status parameter. It determines whether the line is at rest or if a call is currently being made over it. The line type then determines what type of communication floor is installed in the connected CU. The options are LTE or IP. The LTE network section provides information on the LTE network to which the inserted SIM card is currently logged in. The signal strength is displayed in a clear scale, followed by a numerical value in dBm. The name of the provider to which the SIM is logged in. The address assigned by your provider's APN server to the SIM card appears in the IP Address parameter if LTE data transmission is allowed and configured. If data flow is disallowed, ill-configured or unsupported by the SIM, the address will be 0.0.0.0.

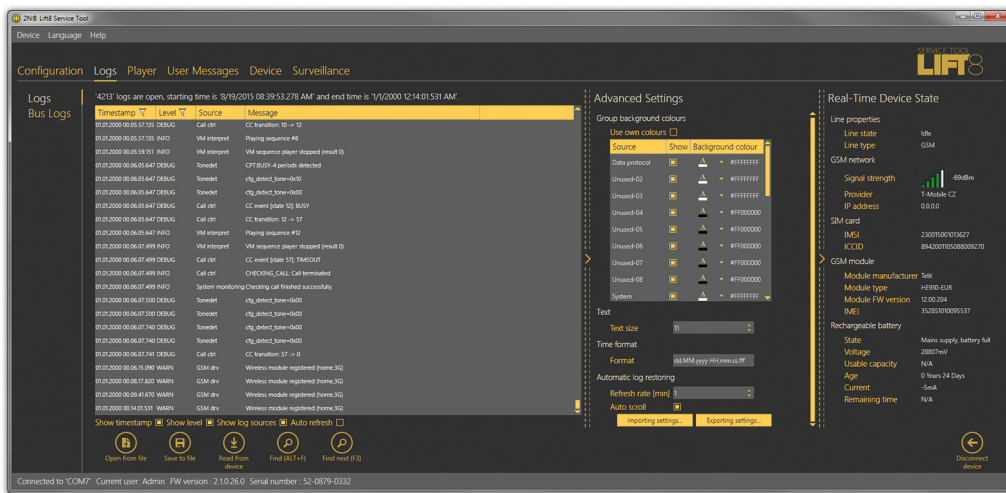

Maximum Application Display with Current Device State

The SIM card section specifies the SIM card state and IMSI and ICCID identifiers. The GSM Module section displays the GSM/UMTS module information. You will also find the module manufacturer, module type, module FW version and IMEI here. The last part, Battery, is devoted to the rechargeable battery packs. The first parameter State always describes the current state of the device. Each state has a simple description. For example, if the CU is mains powered and no batteries are inserted, the "Mains powered, no batteries" description will be displayed. The Voltage parameter always measures and displays the current battery voltage. The value is in mV. If the batteries have a very low voltage, on the order of hundreds of mV, the batteries are disconnected. Usable Capacity indicates the level of charge of the batteries. The value is given in Percentage. Current measures the actual current flowing through the batteries. If the batteries are being charged, this is their charging current. When the CU is disconnected from power and powered by batteries, it is a discharge current. The Age parameter monitors the maximum lifetime of the inserted batteries. The Age counter must be reset when new batteries have been inserted. When the battery life is exhausted, the CU reports an error and the batteries have to be changed. This helps you find out how long your batteries have been used in the device.

If your CU is equipped with a VoIP module, the Current Device State section displays the relevant parameters. See the figure below. The section informs you of the line state and type. The IP Module parameter shows the IP address or address obtained from the DHCP server, network mask, default gateway and DNS server. Finally, like with the LTE module, you can see the current battery and charger states. If you use a PSTN module, the line state and battery charging state will only be displayed.

- Image placeholder -

Current Device State for VoIP Module



CAUTION

Current Device State always displays the Connection Properties and Battery. The other parts are displayed automatically depending on the HW connected.

The logout button is situated in the right-hand bottom corner. More important controls are in the lower part. They may be different in different menus. The table below describes all the buttons available in the application.

Basic Controls



New helps you create a new table of parameters. The existing table will be replaced. You will be alerted of this with a warning.



Open from File helps you read the table of parameters from a disk file.



Save to File helps you save the current table of parameters into a disk file.



Connect Device switches the user into the 'Connect to Device' menu.



New Group helps you create a new CU connection group in the Connect to Device screen.



New Server helps you create a new CU connection in the Connect to Device screen.



Delete Selected deletes the currently selected objects from the list in the Connect to Device screen.



Back returns you to the offline configuration menu.



Connect logs in the user to the configured CU.



Connect to Server connects the user to 2N Lift8 Server and displays the list of set and active Central Units to be connected to. Connect is always used for the CU connection.



The Connect Another Intercom button disconnects the user from the current device and displays the list of devices on the connected 2N Lift8 Server again.



Disconnect Server disconnects the user from the server and displays the Connect to Device screen.



Disconnect device logs out the currently logged-in user from the CU.



Find helps you activate log searching. The Find window is displayed for you to set a string (word) to be found.



Find next helps you find another occurrence of the set string (word).



Read from Device downloads the current settings and logs from the CU.



Save to Device helps you save new parameters into the CU memory.



Get New Image helps you download a preview from the camera connected to the selected camera module.



Rotation to Left turns the image left by 90°.



Rotation to Right turns the image right by 90°.



Add Action adds a new I/O module action.



Delete Action deletes the selected action.



Click Verify to verify the validity of the LUA script for I/O module control before loading to the CU.



Click Save Script to save the current script into a file for backup and later use if necessary. The script can thus be backed up and uploaded again if necessary.



Click Load Script to load a script from the backup file. The original script will be removed.



Click Open Directory to load video files from a disk/SD card.



New Set helps you create a new set of user voice messages.



From Device helps you download user messages from the CU.



To Device helps you upload new user messages into the CU memory.



Load from Directory helps you load the list of user messages from a directory to a disk.



Save to Directory saves the list of user messages into a selected folder onto a disk.



Print HW Setup – diagram helps you print out the current **2N Lift8** HW settings as an image.



Print HW Setup – text helps you print out the current **2N Lift8** HW settings as a text.



Upgrade starts FW uploading to the CU.



The Back button is only in the Connect to Device menu and is used for return to the Configuration/Parameters menu if you do not want to connect to any CU.



Refresh updates the list of connected communicators and the CU bus.



Zoom in helps you get a close-up view of the diagram displayed.



Zoom out helps you see more of the diagram displayed at a reduced size.



Delete Messages in Device erases all the user-recorded messages from a set. After all the parameters are saved, the messages will be deleted from the CU too.



Open from File and Save to Device opens a file viewer for you to select the license file for your CU. This file will be downloaded to the CU upon confirmation.



Start Watching Connected Units activates the function like the Reset button on the CU. From now on, the system will check the audio units (cabin, Fireman only) for proper connection and function. Refer to Subs. [System Completeness Check and Audio Unit Audio Test \(p. 185\)](#) for details.



End Watching Units deactivates the unit watching function.

Use of Service Tool

Upon the application launch, you get to the Configuration main menu and then the Parameters / Basic menu. Here you can find almost all the 2N Lift8 Central Unit settings. You are in the offline configuration, which you can modify, save into a file and prepare for download into the CU any time later. The offline mode helps you view the CU settings and logs. You have access to the Configuration and Logs menus. The other menus are meaningful only if the CU is connected. The meaning and description of the parameters and controls are the same as in the online mode (i.e. with the CU connected). See below for details.



CAUTION

You need authorization to write into the folder where the application is stored to make the application work properly. Unless specified otherwise during installation, the application is located at C:\Program Files (x86)\2N TELEKOMUNIKACE by default.

Configuration

Parameters

After logging in to the Central Unit as described in the previous chapter you will be taken to the main configuration. Parameters / Basic menu, which shows the parameter table. Here you will find all the **2N Lift8** system settings. Each parameter has its own code displayed in the table. Refer to [Overview of All Programming Functions \(p. 129\)](#) for the list of parameters and their meanings.

All the parameters are arranged in associated groups for convenience. Moreover, each table row is equipped with a hint, which describes the parameter purpose and setting options. The table includes the following items: Code matches the parameter number in the CU voice menu, Name displays the parameter name, Value shows the currently set parameter value. Unit specifies the parameter unit. If no unit is specified in this column, the value is just a number. Maximum and Minimum define the permitted range of the values to be set. Default Value displays the factory value of the parameter, which also appears after the factory reset. Click this value to add it to the Value column.

Service Tool

Device Help

Configuration Evacuation Logs User Messages Device Surveillance

Parameters
IO Modules
Events
Port forwarding

Code	Name	Value	Unit	Min	Max	Default value	Favorites
011	Set 1 - ALARM button memory 1	sip:2959980891	-			<empty_string>	★
012	Set 1 - ALARM button memory 2	Enter here	-			<empty_string>	★
013	Set 1 - ALARM button memory 3	Enter here	-			<empty_string>	★
014	Set 1 - ALARM button memory 4	Enter here	-			<empty_string>	★
015	Set 1 - ALARM button memory 5	Enter here	-			<empty_string>	★
016	Set 1 - ALARM button memory 6	Enter here	-			<empty_string>	★
018	Set 1 - Count of automatic dialing cycles for ALARM	1	number	0	9	3	★
021	Set 2 - ALARM 2 button memory 1	Enter here	-			<empty_string>	★
022	Set 2 - ALARM 2 button memory 2	Enter here	-			<empty_string>	★
023	Set 2 - ALARM 2 button memory 3	Enter here	-			<empty_string>	★
024	Set 2 - ALARM 2 button memory 4	Enter here	-			<empty_string>	★
025	Set 2 - ALARM 2 button memory 5	Enter here	-			<empty_string>	★
026	Set 2 - ALARM 2 button memory 6	Enter here	-			<empty_string>	★
028	Set 2 - Count of automatic dialing cycles for ALARM 2	3	number	0	9	3	★
029	Allow usage of alarm set 1 when set 2 is empty	1	number	0	1	1	★
111	Set 1 - Number 1 confirmation mode	1	number	1	9	1	★
112	Set 1 - Number 2 confirmation mode	1	number	1	9	1	★

Expand groups Collapse groups Favorites

New Open from file Save to file Read from device Save to device Disconnect device

Connected to '10.0.26.141/7007' FW version : 3.1.5.0.1 HW version : 4.0 Serial number : 92-0145-0003 MAC address : 7C-1E-B3-EC-06-72

Parameters – Basic Menu

The menu also includes the Expand Groups / Collapse Groups buttons. They help you expand the sections and display all the required parameters quickly. Click the Favorites next to the Collapse groups button to display your favorite items in the table. Click the empty star symbol behind a parameter in the Favorites column to select a new favorite item. You unselect the item similarly. The star symbol without filling is not a favorite item. The Expand Groups/Collapse Groups buttons are also used for displaying your favorite items. As is filtering. A yellow-to-orange color change of the Favorites button means that the favorite items are only active. Click New Set to overwrite the current settings with default values. Click Save to File to back up data onto your PC disk. Push Open from File to read the backup data. The Read from Device button helps you read the current set of parameters from the CU. Finally, click Save to Device to save the changes into the CU memory. Filtration is a convenient searching tool. Set the filter for each column separately and combine the filters to find the required data as quickly as possible. Click the funnel symbol in the selected column to activate the filter. Activation is indicated by a color change of the funnel symbol. See the figure below.

	Code	Name	Value
^ Alarm Call			
	011	Set 1 - ALARM button memory 1	22527128
	012	Set 1 - ALARM button memory 2	Enter here

Left – Inactive Filter, Right – Active Filter

Each column with the funnel symbol includes filter settings. See the figure below for an example. The Contains function finds the searched string in all the column items and returns all the occurrences. Enter a text into the string field and click Filter to activate the filter and find all the searched items in the column. Use another filter to make your search more precise and efficient. Having completed filtering, click Delete filter in the used columns to delete all the active filters. If you did not delete the setting, the filtration settings would keep active even upon the CU logout. You would obtain filtration results again instead of complete information in your next search.



TIP

You can also delete the configured filters via the context menu under the right mouse button or by clicking Alt+R.

	Code	Name	Value	Device	Min	Max	Defau
^ Alarm Call							
	021	Set 2 - ALARM 2 button memory 1	Set 2				<empty>
	022	Set 2 - ALARM 2 button memory 2					<empty>
	023	Set 2 - ALARM 2 button memory 3					<empty>
	024	Set 2 - ALARM 2 button memory 4					<empty>
	025	Set 2 - ALARM 2 button memory 5					<empty>

Filtration Setting Result

The pencil symbol appears in the row if the native value of the parameter has been changed to another value. You can then clearly see what parameters have been modified in the configuration.



TIP

Each table row is equipped with a hint including parameter description for convenience.

I/O Modules – Basic

Open the I/O Modules menu to configure the I/O modules. There are 8 frames in the window. Each of the frames symbolizes one I/O module on the given address. Each frame includes an I/O module icon, which symbolizes the module state, plus the module number and state description. A grey icon and greyish 'Disconnected' description indicate an unconnected I/O module. If the I/O module is connected to the Central Unit, it means that it is online. A yellow-highlighted icon plus a green 'Connected' text indicate that the I/O module is connected. See the figure below.

Service Tool

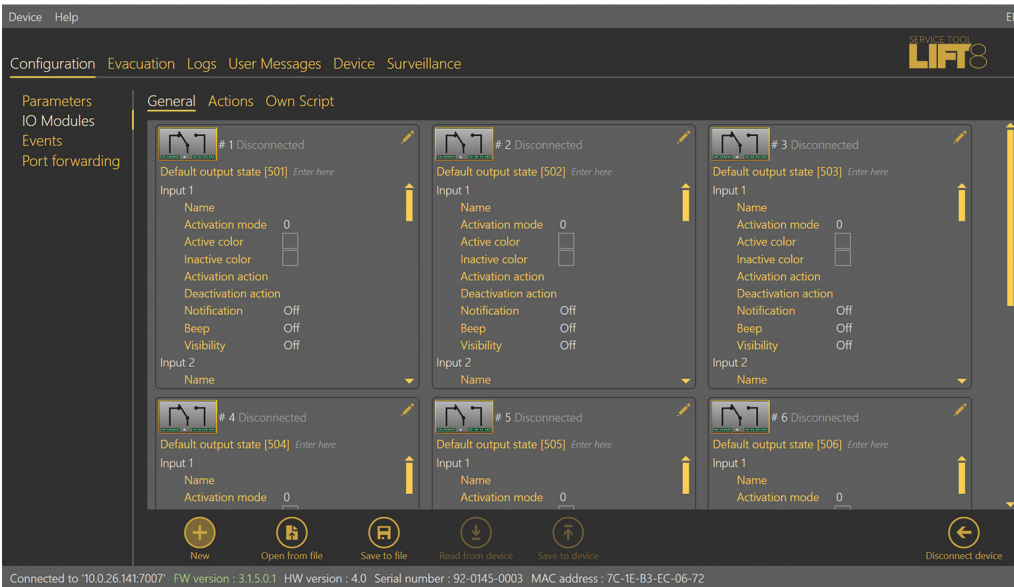

I/O Modules – Basic Menu

There is a button with a pencil icon (Edit) in the right-hand upper corner of each frame. The Edit button helps you switch to the configuration of the corresponding I/O module. Click Edit to open a new window – I/O module configuration. Like in the overview, the I/O module state is displayed in the upper part of the window. The I/O module input settings are displayed below the I/O module state.

Name is the first parameter in the window. Select the input name here. We recommend choosing a brief description for the input-monitoring sensor type and location (Smoke sensor on shaft ceiling, for example). The next parameter is Activation Mode. Actually, it is a negation of the input circuit. If you set 1, the input is active if logic 1 is set on it. If you set 0, the input is active at logic 0. The following settings define the colors of the active/inactive input. These colors are then displayed for the corresponding inputs in the Supervision menu. Activation Action sets what is done if the input goes into the active state. Deactivation Action specifies what happens during the active-to-inactive state transition. Set these actions in the Actions menu below. The output settings are more or less similar to the input settings. Set the output name with respect to the output function (Fan 4, e.g.). The Activation Mode parameter sets the negation of the output relay. This means that to be activated, the relay should be open and vice versa. Again, the colors are set here for the outputs listed in the Supervision menu.

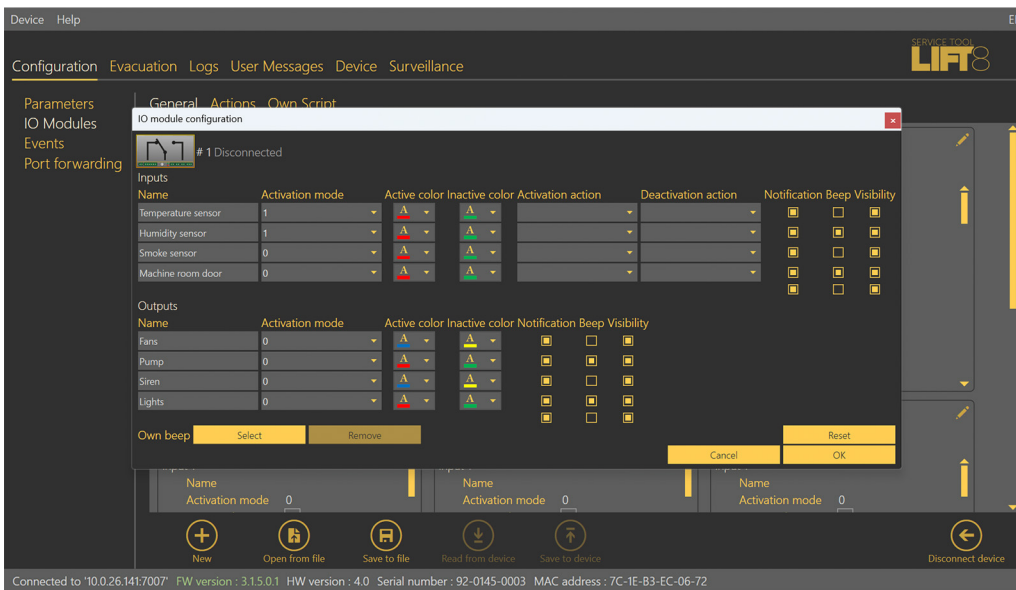

I/O Module Configuration Window

Select/unselect the checkboxes to the right to enable/disable display of relevant information. Select Display Inputs to display information on all the I/O module inputs. The same applies to Display Outputs. Select Notification to enable/disable the notification pop-up window. Tick Beep to enable sending of the dialtone to your system output (speakers/headset) whenever a new notification message arrives. Find Custom Beep in the left-hand bottom corner. This gives the user the option to choose their own audio file to be played. Click Select to select an audio file from your disk. Press Remove to remove the user file and start using the default sound again.

I/O Modules – Actions

The Actions menu helps you set the actions/commands to be executed. These actions are initiated by changes on the I/O module inputs and set as shown above. Click Add Action to create a new action. Another setting option opens to the right. Here you can rename the newly created action in the first parameter. The following is a list of behaviors. You can specify a list of tasks to be performed for each action. There are four basic tasks. Activate, Deactivate, Send SMS and End Rescue. Activation activates the relay contacts. Select more parameters in the Advanced settings to the right: Module number on which the relay state change occurs, output number including description for better orientation and task duration. Similarly, Deactivate opens the relay. The other parameters are identical with the activation parameters. The Send SMS task is different, where you set the phone number to which the set message should be sent. The message text with a maximum length of 160 / 70 characters is then entered into the text field. Depending on the encoding type. Use GSM 03.38 or UCS 2 for diacritics and non-standard character sets. One SMS is sent at a time. Long, multipart SMS are not supported. End Rescue helps you select the shaft for which the Rescue mode shall be terminated. It is also possible to mark multiple shafts at the same time. If you do so, the Rescue mode will be terminated in all the selected shafts. Click Load configuration to save the actions to the device on the Basic tab.



TIP

- If you keep the default value 0 in the Duration parameter, the relay will keep closed/open during the whole input activation time.
- Example: if input 1 keeps 10 s at logic 1, the assigned relay 1 will keep closed for 10 s too.

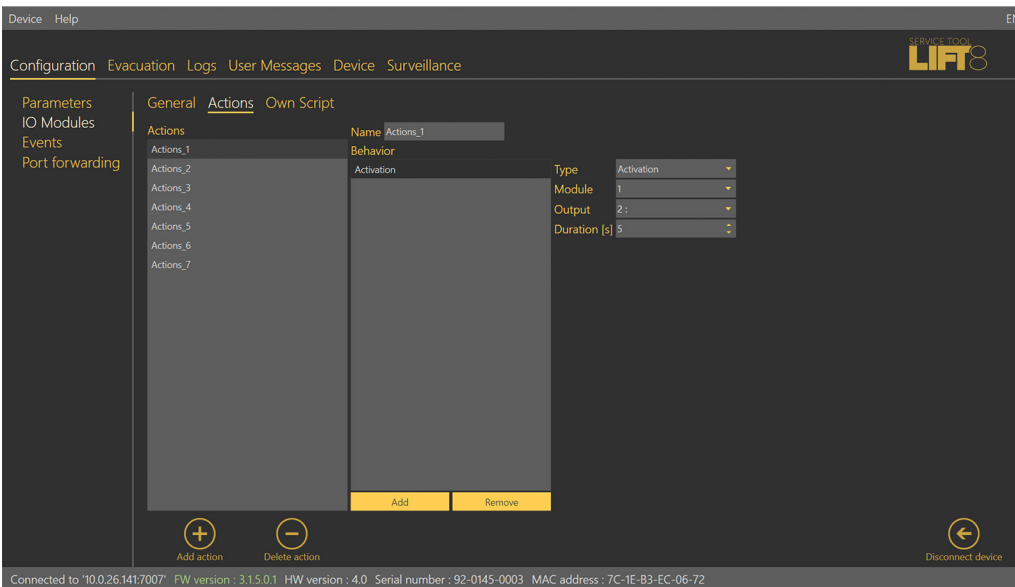

I/O Modules – Actions Menu

I/O Modules – Own Script

The Own Script menu enables advanced users to edit scripts with own installation logic instead of using graphical action settings. This solution is useful for installations where identical parameters are defined and can be simply copied to multiple central units. The LUA open-source programming language is used for the script. Refer to www.lua.org for more details.

To start writing your own script, you must first check the Active checkbox. This will disable the existing set actions using the GUI and activate the settings using a custom script. Programming should be made by a duly trained person. Refer to faq.2n.com for examples. Having completed editing, click Verify to check the code entered. Click Save Script to save the properly verified code onto your PC disk. Click Load Script to load a file from the disk and add it to the script editing field. Click Load Configuration on the Basic tab to save the completed script to the device. The functions below are available.

Features	Description	Parameters
io_out(m,a,s)	Set module output state	m=module_pos a=output_addr s=output_state

Features	Description	Parameters
io_in(m,i)	Get module input state	m=module_pos i=input_addr return input state
io_changed(m,i)	Check module input change	m=module_pos i=input_addr return true if input changed
io_ready(m)	Check module connected	m=module_pos
send_sms(p,s)	Send SMS	p=phone_num s=sms text
rescue_end(<shaft_list>)	Rescue mode end	shaft_list=shaft numbers separated with a comma The Rescue mode is terminated in the shafts where no alarm call is active.
io_out_get(m,a)	Output value	m=module_pos a=output_addr

Events

The Events menu helps you configure how the CU shall behave when an event is detected. The events are mostly pre-defined system events. You just choose the type of response to them. The following events are defined at present:

- Replace battery – the event is activated automatically when the set battery life expires or the battery capacity is too low. Refer to Subs. 4.11 for more details.
- Button stuck – use parameter 969 (Test <guibutton>ALARM</guibutton> button) for configuration. Refer to Subs. 4.9 for more details.
- Rescue end – the event is executed when the rescue process has been completed. Refer to Subs. 4.10 for more details.
- Audio error – the event is activated when the audio test fails for three times. Refer to Subs. 4.8 for more details.
- Battery replaced – OK state to Replace battery.
- Button fixed – OK state to Button stuck.
- Audio fixed – OK state to Audio error.
- Battery capacity according to EN 81-28

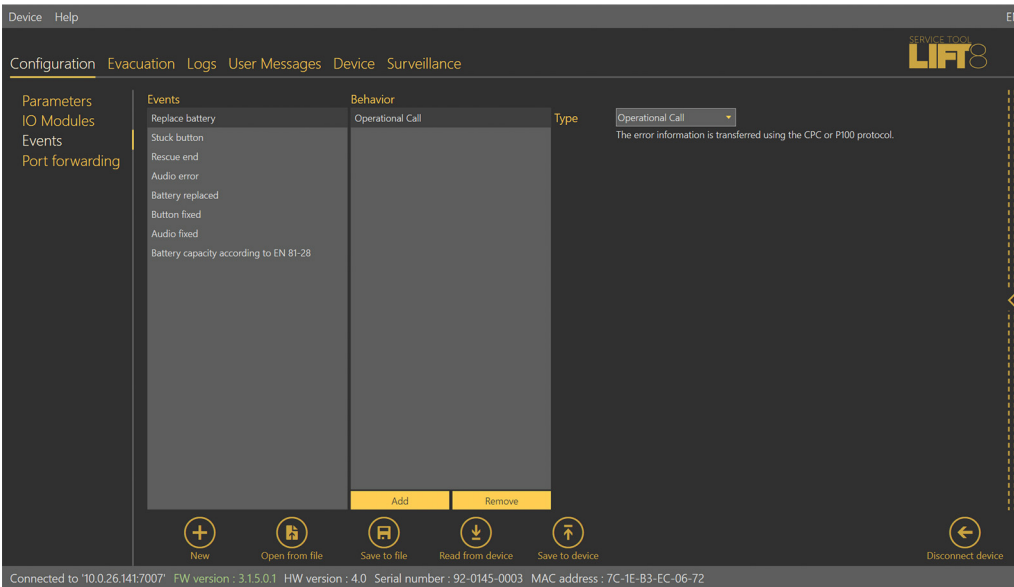

Events Menu

When an event is detected, you can specify a list of tasks to be performed. There are five basic tasks. Activate, Deactivate, Send SMS, Send System SMS and Error Call. Activate activates the relay contacts. Select more parameters in the Advanced settings to the right: Module number on which the relay state change occurs, output number including description for better orientation and task duration. When set to zero, the output state change is permanent. Similarly, Deactivate opens the relay. The other parameters are identical with the activation parameters. The Send SMS task is different, where you set the phone number to which the set message should be sent. The message text with a maximum length of 160 / 70 characters is then entered into the text field. Depending on the encoding type. Use GSM 03.38 or UCS 2 for diacritics and non-standard character sets. One SMS is sent at a time. Long, multipart SMS are not supported. Send System SMS means that the message text is predefined in the system and the only parameter to be completed is the phone number. In the Operational call type, the Central Unit makes a phone call to the number preset in the error call set. Parameter 081–086. The error information is then transmitted via CPC or P100. Click Save to Device to save the actions into the device.



CAUTION

- You can send SMS only if your CU is equipped with an LTE module.
- Make sure that communication via CPC or P100 is set correctly in parameters 181–186 to make successful error calls.

Port Forwarding

Port forwarding helps you get connected to the devices located in the LAN. It is because such devices are hidden behind the WAN IP address to the public Internet users. This service can only be used via a VoIP / LTE module. It is because the PSTN module does not support this type of data transmission. The user gets connected to the external WAN address and a defined port. Then, the user is automatically forwarded to the LAN IP address behind the LAN module or another port as defined by the user.

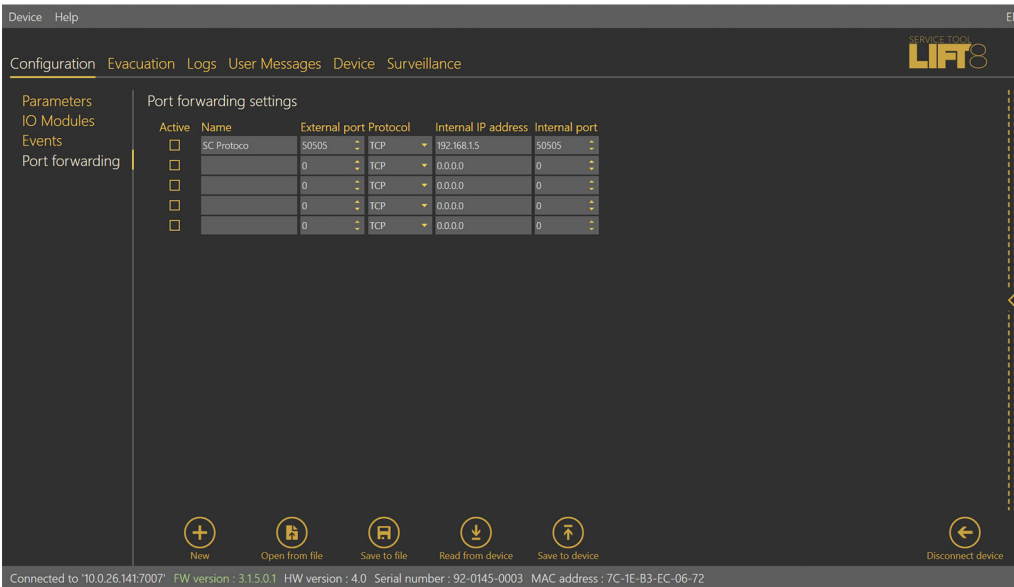

Port Forwarding Menu

In the menu, it is possible to define five ports that will be redirected according to the set parameters to the selected IP addresses. The Active checkbox enables individual rules. In the next field, the rule can be named. Next is the external port to which the user will connect. Protocol means the type of communication: TCP or UDP connection. Internal Address depends on the LAN module range and Internal Port is a LAN port to which communication is to be forwarded.



CAUTION

- Never reroute the Lift8 system ports used for communication. These are mainly the following ports:
 - 7007 – Service Tool communication port
 - 7008 – Lift8 Server default communication port. To change this port, refer to parameter 1232.
 - 5060 – SIP PROXY default communication port. To change this port, refer to parameter 1109.

Logs

The Logs section helps you view the diagnostic reports included in the log files. No logs are displayed upon the application launch. First upload the logs from a file or, after connecting to the Central Unit, download the current logs from it.

Logs – Basic

The Logs – Basic menu includes a table with necessary data. Use the checkboxes below the table to select the table columns. Select the parameters to display the required information. It is possible to display/hide the timestamp, log level and log group. Click Autorefresh to enable automatic screen update in selected time intervals. Press Read from Device to read the current logs from the CU connected. The following items

Service Tool

are displayed in the table: Timestamp defines the date/time in which the event was captured. Level and Source which define the log type and source respectively. Message includes the information itself. The State parameter above the table specifies how many logs (rows) have been read and the log start/end time.

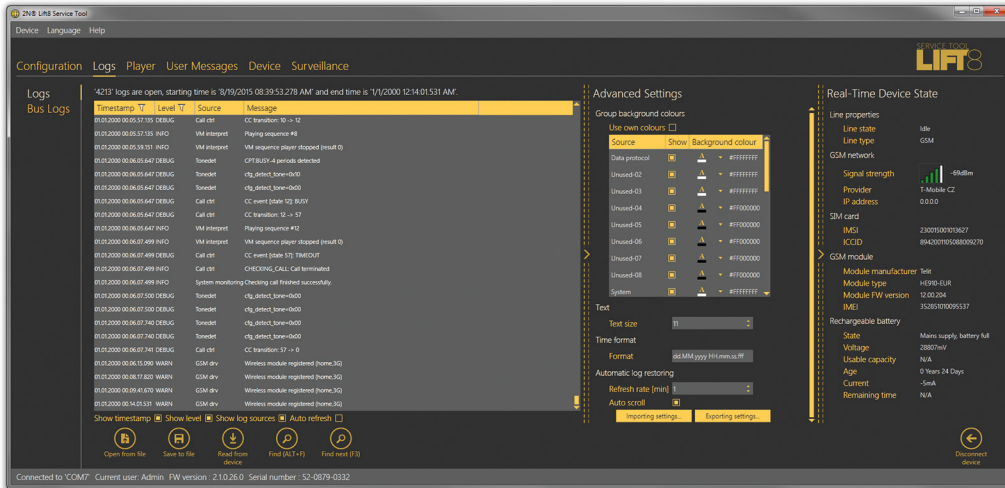

Logs Menu

Save the captured log for later analysis in the left-hand bottom part. Click Find to find a message in the log. Enter the string to be searched in the dialog box. Click Filter to find the first occurrence. Click Find next to find the next occurrence. Use Advanced settings to enable/disable message types and assign colors for easier log displaying. More advanced options are available. See below for details.



TIP

The logs should only be analyzed by duly trained persons or your Technical Support department.

Log Finding

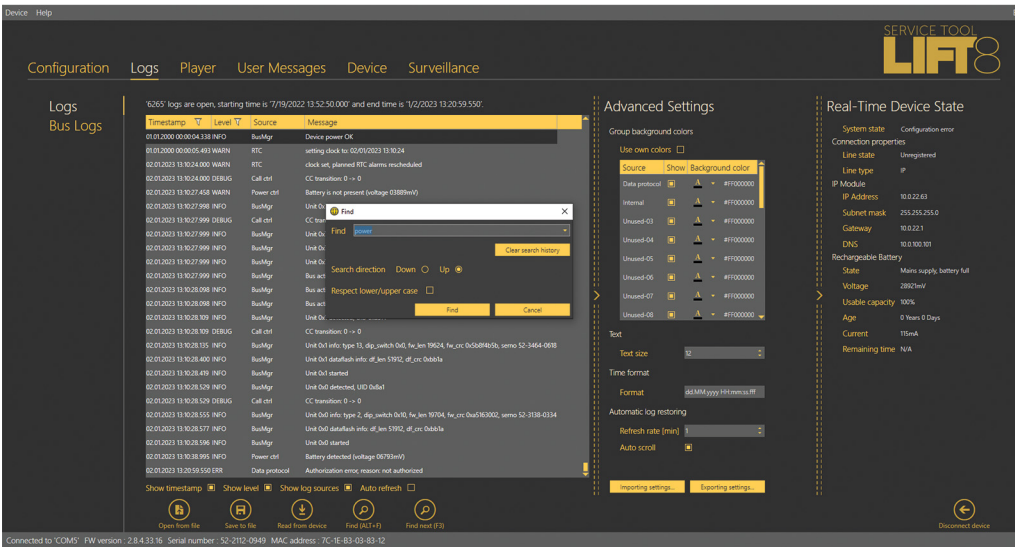

Find Function

Use the Alt + F combination to find the logs in 2N Lift8 Service Tool. In the Find browser, you can also use the Delete History function to delete all strings left in the Find field. Use Upper/Lower case for search facilitation if necessary.

Logs – Advanced Settings

The Advanced settings menu is displayed to the right in a hideable form. Background Colors helps you set specific background colors for the selected messages. Select the Use Custom Colors checkbox to activate the user background color settings for the log groups located below. The change will occur immediately after check-off. It is also possible to set your own sorting of date and time information. You can use the default system date and time order or set an order of your own. The parameter does not have to contain all the data dd.MM.yyyy HH.mm.ss.fff. Their order and ranking are purely up to you. You only need to follow the general rules for Custom Date and Time Format Strings. Their explanations can be found, for example, [here](#). In the Text section, you can adjust the size of the displayed font. The last option of the Advanced settings is Automatic Log Refresh. In the parameter, set the refresh rate in minutes and whether you want to automatically scroll the display so that the last (most recent) log row is always visible. Enable this function by checking the last checkbox under the main table, as mentioned above.

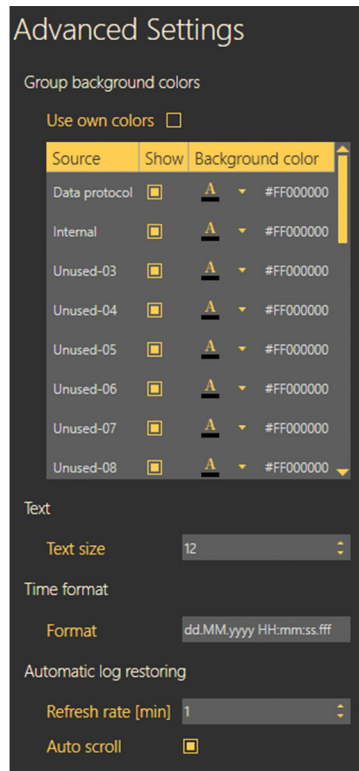

Advanced Settings

The last buttons help you save the advanced settings to your PC disk for later use. To do this, use Save Configuration. Press Upload Configuration to upload your log display configuration.

Bus Logs

This menu has been introduced specifically for monitoring all communication states along the bus between the bus-connected devices and the Central Unit. All communication that takes place on the bus is logged to these rows. Each row symbolizes one device connected. The table columns specify the device, bus, address (for later search in the Logs menu) and communication parameters.

Service Tool

unit	line	addr	txpkt	txbytes	rxpkt	rxbytes	E_crc	E_bufovf	E_break	E_frame	E_noise	E_overrun	txreq	rxreq	E_bxreq	E_bxretrj	E_drop_req	E_drop_resp	E_drop_ack
CU	6	0xFC	42431	297315	16623	199291	0	0	0	0	0	0	18071	51	1552	7786	0	3	0
CU	2	0xFC	0	0	0	2	0	0	0	0	0	0	1727	1	0	0	0	0	0
SPL	6	0x17	2975	25198	5933	413492	0	0	0	0	0	0	1	2965	0	0	0	0	0
SPL	2	0x17	2471	17339	1285	11739	0	0	0	3	2	0	2	49	0	0	0	0	0
SPL	6	0x37	3007	25556	5994	414342	0	0	0	0	0	0	1	2991	0	0	0	0	0
SPL	2	0x37	2520	17703	1404	13037	1	1	0	19	1	0	2	147	0	0	0	0	0
SPL	6	0x57	3012	25599	6001	415642	0	0	0	0	0	0	1	2993	0	0	0	0	0
SPL	2	0x57	2515	17668	1370	12720	1	1	0	22	1	0	2	114	0	0	0	0	0
SPL	6	0x67	3006	25513	5995	416924	0	0	0	0	0	0	1	2989	0	0	0	0	0
SPL	2	0x67	2515	17654	1343	12442	1	1	0	12	0	0	2	88	0	0	0	0	0
SPL	6	0x77	3008	25477	5998	418294	0	0	0	0	0	0	1	2997	0	0	0	0	0
SPL	2	0x77	2500	17549	1364	12672	0	2	0	6	3	0	2	113	0	0	0	0	0
IO	6	0x86	1754	14055	3500	431156	0	0	0	0	0	0	3	1749	0	0	0	0	0
AU	2	0x10	254	2310	3550	29990	0	0	0	631	1	0	2	251	0	0	0	0	0
AU	2	0x11	276	2510	3512	29532	0	0	0	621	0	0	1	251	0	24	0	0	0
AU	2	0x12	253	2327	3551	29977	0	0	0	623	0	0	1	251	0	1	0	0	0
AU	2	0x13	274	2492	3517	29683	0	0	0	625	0	0	1	251	0	22	0	0	0
AU	2	0x14	253	2303	3572	30264	0	0	0	643	1	0	1	252	0	0	0	0	0

Bus Logs

Click Save to File to save a log for later use. Click Open from File to open the statistical data offline. See the table below for the columns.

unit Unit name (CU = Central Unit, AU = audio unit, SPL = splitter, IO = I/O module)

line Line type (6 = 6wire, 2 = 2wire)

addr Unit address

txpkt Count of Sent Packets

txbytes Count of Sent Bytes

rxpkt Count of packets received

rxbytes Count of bytes received

E_crc Count of CRC errors

E_bufovf Count of UART errors – buffer overflow

Service Tool

E_break	Count of UART errors – incorrectly received break
E_frame	Count of UART errors – incorrectly received frame
E_noise	Count of UART errors – incorrectly received bit
E_overrun	Count of UART errors – received byte overwritten with a new value
txreq	Count of requests sent
rxreq	Count of requests received
E_txreq	Count of incorrectly sent requests
E_txretry	Count of incorrectly received requests
E_drop_req	Count of discarded requests (duplicate requests)
E_drop_resp	Count of discarded replies (duplicate replies)
E_drop_ack	Count of discarded reply confirmations (duplicate confirmations)

Evacuation

The Evacuation menu administers the audio unit list in the Evacuation mode. 8 positions are allocated for each splitter regardless of the actual count of audio units connected to the splitter. The numbering of the audio units may not correspond to the numbering of the floors in the building, for example, where less than 8 audio units are connected to a splitter or the audio units are installed in underground garages (-1). Therefore, you can name the audio units in the Evacuation menu. These names propagate to the system diagram on the Surveillance tab.

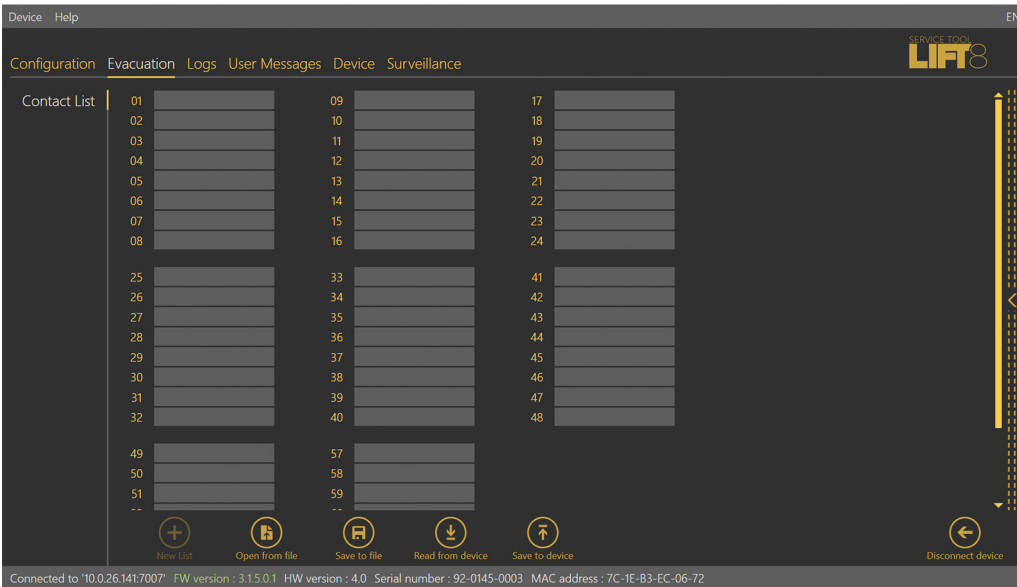

- New List – open an empty audio unit list to enter the names. Select Upload to device to upload the changes into Lift8.
- Open from File – import data from an XML file. Thus, it is possible to upload a directory to the Lift8 Service Tool downloaded from a 2N IP Phone D7A in the evacuation control room.
- Save to File – export the completed data into an XML file. This file is compatible for import to the 2N IP Phone D7A directory in the evacuation control room.
- Read from Device – read the current contact list uploaded in the Lift8 Central Unit, which controls the system.
- Write into Device – save the changes and overwrite the contact list saved in the Lift8 Central Unit, which controls the system.

User Messages

User Messages helps you replace the default system announcements with user messages. Load these messages from a file or, in the correct format, via the 2N Lift8 Service Tool. Use a microphone connected to your PC for recording.

Messages

The Messages menu displays the list of User Messages that can be replaced with custom files if necessary. When you enter the menu, the list is empty. Choose how to fill it. There are three options. You can click the New Set button. This will display a list of all messages. This list is empty and can be replaced entirely with custom messages. Or, use the Upload from Device option. This downloads the current set of messages used in the connected Central Unit. Or, click Load from Directory to import a set of messages saved on your disk. Select the folder with the set of messages and confirm your selection. The selected set will be loaded into the application.

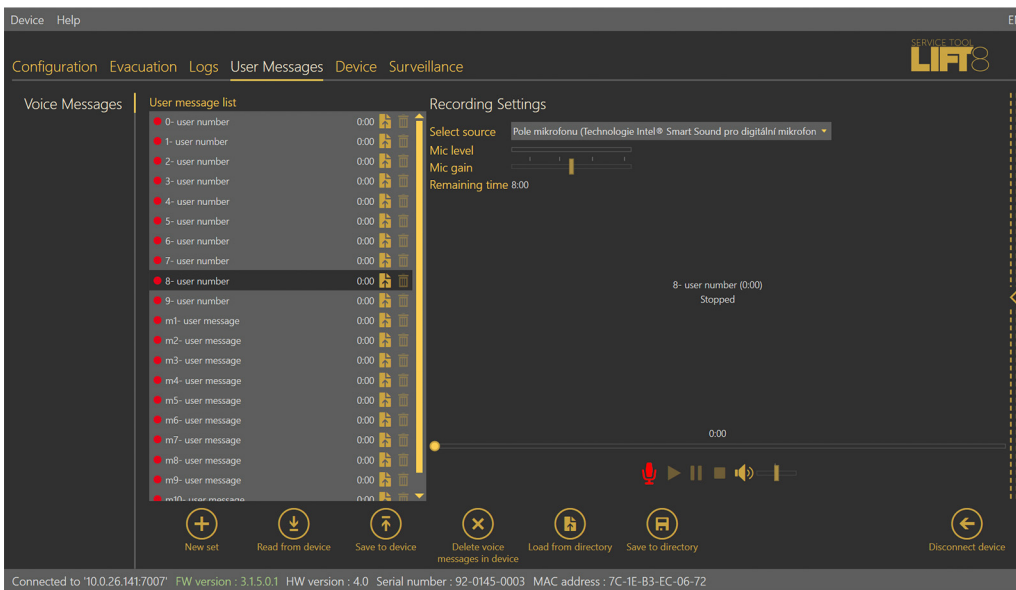

User Messages – Messages Menu

The User message list displays the message time and two action buttons: Load Message from File and Delete. If the message is not recorded, the total time is 0:00. Once you record a message, the total time will be displayed. Click this import button to open the disk file viewer for you to replace the message with another, correctly formatted file. If you just select a message, the message recorder will become available to the right. The message can be played back using this recorder. Standard recording functions are available. Press Play to play the message. To record new messages, you must first select the correct input device from which to record the sound. When the microphone icon shines red, start recording a new message. The preceding one will automatically be deleted and the new one will be recorded.



NOTE

- The correct format for a message to be added is .WAV. No other files can be uploaded.
- A message cannot be recorded until the input device is selected in the recording settings.

The menu is faded while a new message is being recorded. The recorder displays the message name, total time and current state. This indicates active recording, playback or playback stop. Click the Stop icon to stop recording. Click Play to check the currently recorded or imported voice message. If the message volume level is too low, adjust the input device volume. This can be used to slightly amplify the played messages. If the message volume is still low, try another device for recording. Having completed message editing, click To Device. This uploads the message set into the CU connected. Click Save to Directory to save the current file onto your PC disk. Select a message and click the Trash icon to delete the message. The message will be deleted.

**CAUTION**

The output volume value in the application does not affect the master volume of the record to be saved into the CU. If the record volume is too low, repeat recording with a higher volume level.

**TIP**

Use high-quality microphones for recording. Stay in a noise controlled room with good acoustic properties while recording to avoid poor recording quality and interference.

Recording Settings

The Recording settings are located in the left-hand upper corner of the screen. They help you select the input source and control the microphone gain. The first parameter is Select Source, where you select the input recording device from a list of available devices. Integrated/external microphone or line input. The following is the Mic Level. Mic Level defines the microphone input drive level. The last but one parameter is Mic Gain. Mic Gain defines the input gain. The total memory capacity for all the messages to be saved into the CU is 8 minutes. Refer to the Time Left parameter for the remaining message editing time.

**NOTE**

- If the microphone input is overdriven during recording, turn down the mic input gain. If the record is too silent, turn up the mic input.
- In case the application gain setting is not sufficient, use the system controllers or an external amplifier.
- When the maximum message time (8 minutes) is exhausted, no more messages can be added. Thus, optimize the message time to record all of your messages.

Devices

The Devices menu provides information on the 2N Lift8 Central Unit connected: basic parameters and text/graphic diagram of the available audio units and splitters. In addition, you can upgrade the Central Unit here too.

Info

The Info menu provides basic information on the state of the device connected.

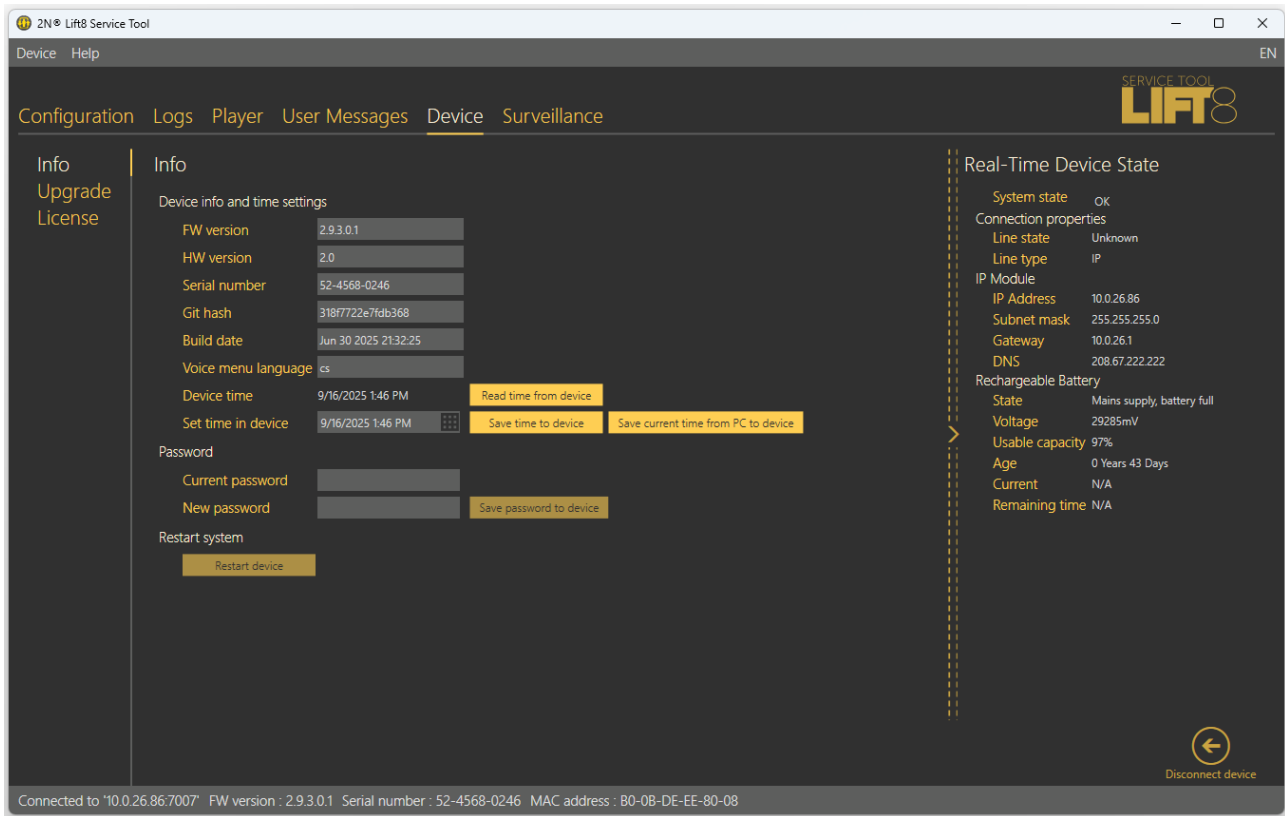

The correct time value can be set here. The Time in Device parameter displays the current time read from the CU. This parameter is not read online and has to be updated using the Read from device button. Set Time in Device helps you record a time setting of your own. Click the Calendar to set the date/time in hours manually. You can overwrite the setting and set a different time value for a different time zone. Click Confirm to confirm the new setting. Click Save Current Time from PC to Device to synchronize the CU time with your PC time value. The new setting will be loaded to the connected CU automatically.

In the Passwords section, you can change the administrator password connected to the CU and set a service password to be used for programming over the call ([2N Lift8 Programming \(p. 123\)](#)).

- The administrator password is the password you use to log in to the Service Tool and is used in the SMS commands. Lift8 cannot be further configured without the administrator password set.
- The service password is the password for entering the voice menu and programming via a call (using DTMF).

If necessary, **Restart Device** or **Factory Reset** is also available. Click the button to restart the CU. You will be automatically logged out once you press the button.

Upgrade

The Upgrade menu offers the possibility to upgrade the firmware of the Central Unit. Two lists are displayed in the menu: List of applicable firmware and List of applicable voice menus. In the menu, you can see the license file that you agree to by upgrading. The firmware is available depending on the hardware version of the Central Unit connected.

Click the appropriate FW version and voice menu type to be loaded to the CU. Click the FW name to select the firmware and voice menu. It is tagged and ready to be uploaded. Having chosen a name, press Upgrade. The 2N Lift8 Service Tool uploads the new FW and Voice Menu to the Central Unit.

**CAUTION**

Having upgraded the FW you will be notified of the CU restart. After confirmation, the restart will be made and the application will be disconnected. Reconnection will not be possible until the system upgrades the audio units and restarts. This process may take a few minutes in extensive systems.

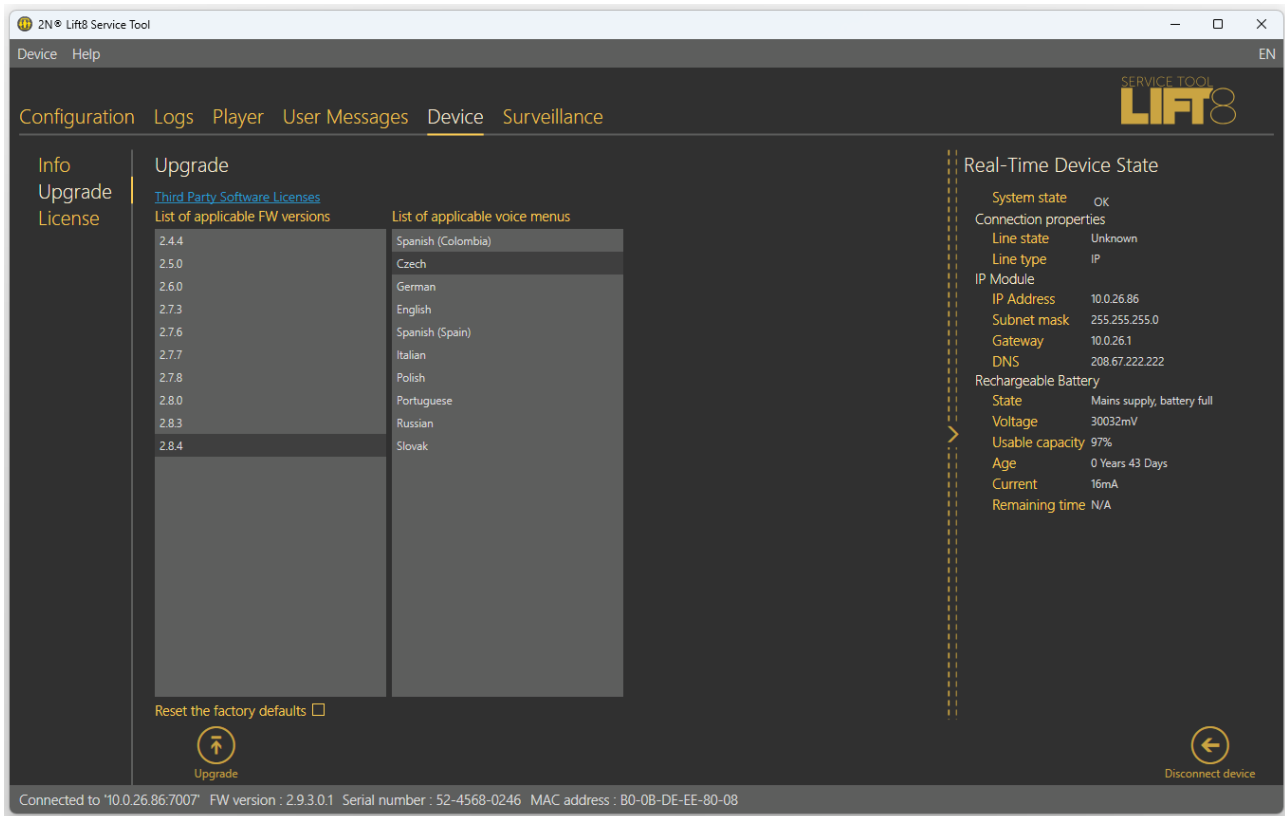

Activate the Factory Reset Configuration checkbox to delete all user-changed values and use factory configuration for the selected audio unit. Select this option and click Upgrade to reset the factory values upon upgrade. This action is always accompanied by loading of a new FW, Bootloader or Voice Menu version to the audio unit. To set the default values only, use the Configuration menu.

Licenses

The Licenses menu is used for adding license files. The licenses to be added to the CU are only applicable in the UMTS/GSM module versions. The license enables/disables the network (provider) to which the device shall log in. Enter the IMSI code into the license. Particularly, the MCC and MNC help define the country and provider permitted for the CU. Enter a greater portion of the IMSI code to specify the SIM cards to be used in one network. You can add up to 10 IMSI codes to the license. Contact your 2N LIFT8 supplier or the manufacturer's Technical Support department (sales@2n.cz) for the license file.

Having acquired the license file, click Open from File and Load to Device. This opens a file browser for you to find the license location and click Confirm. The program will notify you of the license change and necessary device restart. Confirm your selection. Re-log in and check the license. The Allowed IMSI item will display the IMSI codes permitted by the new license.



CAUTION

- Loading licenses for another serial number into the CU cannot be performed. Such attempts will be rejected.
- If you fail to log in to an LTE network, it is possible that the license permits a different IMSI range, which does not match the currently inserted SIM card. This state is indicated as follows: The LTE module has a sufficiently strong signal, but the EXT. line LED is shining red. In that case, insert the correct SIM card or change the license file.
- The License Features only apply to the CUs equipped with an LTE module.
- There is no limitation as to the other PSTN/VoIP communication interfaces even if the license is added to the CU.
- If your CU does not include any license file, its function is not limited and the inserted SIM card can log in to the provider's network, yet with some limitations (roaming, e.g.).

Surveillance

Connected Units

The menu provides a graphical overview of all the units connected to the 2N Lift8 system. The following control buttons are available in the menu: Refresh to refresh the displayed structure. Print HW Setup (diagram / text). These buttons allow you to print a diagram or text description of all the calls and splitters that are connected to the Central Unit. The diagram will print the same view that you see in the application. The text description contains the same information as the diagram. It is just not displayed graphically but in an XML list from which the image is generated. Once pressed, the buttons perform export directly to the printer. The Zoom in and Zoom out buttons are then used to determine the magnification level of the displayed schematic. If you want to see the whole structure, use Zoom out. If you need to see the audio unit details, click Zoom in. The unit watching buttons help you enable/disable the function. The system behaves like with the Reset button. All the units to be watched are green-highlighted and an error is detected and displayed if there is a loss of connection; see the figure below.

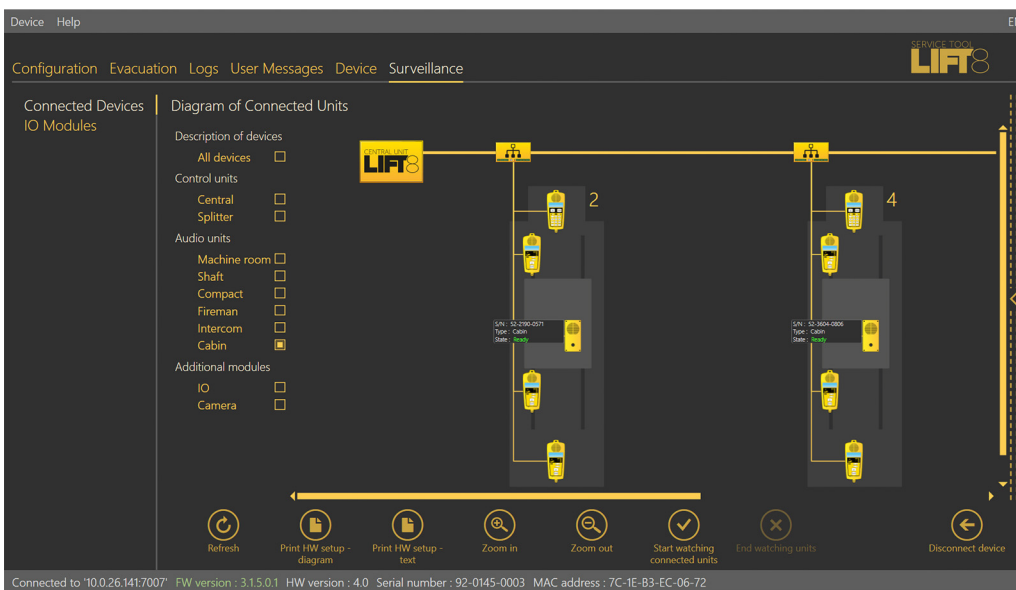

Devices – Connected Units – Diagram of Connected Units

Diagram of Connected Units

The diagram displays graphically all the devices connected to the selected CU. The buses on which they are connected and the shafts and positions in which the audio units are located are shown graphically. In the left part of the window, you will find several checkboxes in the Unit Description section. Enabling the parameter will display a more detailed description of the corresponding audio units. Use the checkboxes to select which type of audio units will be marked. See the figure below. In this short description, displayed to the left of the audio unit, you will find the audio unit serial number, type and state. The same description is displayed as a hint if you hover over the unmarked audio unit.

If you use the system completeness check, the audio units to be monitored (cabin, Fireman) are marked either green or red. Green means that the audio unit works properly. Red means that the audio unit is in the error state, fails to communicate or is absent in the system. It is disconnected. Get the audio unit repaired as soon as possible to make your system complete. Or, remove the audio unit from checking in the system completeness check configuration described in Subs. 2.1 on the Central Unit.

I/O Modules



I/O Modules Menu

The I/O Modules menu helps you monitor the states of the I/O modules connected. The I/O modules section displays all the modules connected to the bus. Each module is identified with a number, which corresponds to its HW address set on the PCB. Furthermore, states of all the inputs and outputs are included. The inputs and outputs are set to 0 by default upon the system startup. Logic 0 is on the input and the relay is open. Use the settings in the Configuration / I/O Modules menu to change the relay position upon startup. A change of the input signal level or setting the relay into the open state will change the signal from 0 to 1 and the user will be notified of the change by a LED color change and text notification, which provides information on the module, input and signal value that initiated the event. This notification is displayed in a special pop-up window, which is not closed automatically. Its closing has to be confirmed with a cross. In this way, the user is always duly informed and cannot miss any input change. Disable notification in the Setting / Configuration menu. You can also choose a module to be listed. If you do not enable module displaying in the Configuration menu, the module will not be visible here.

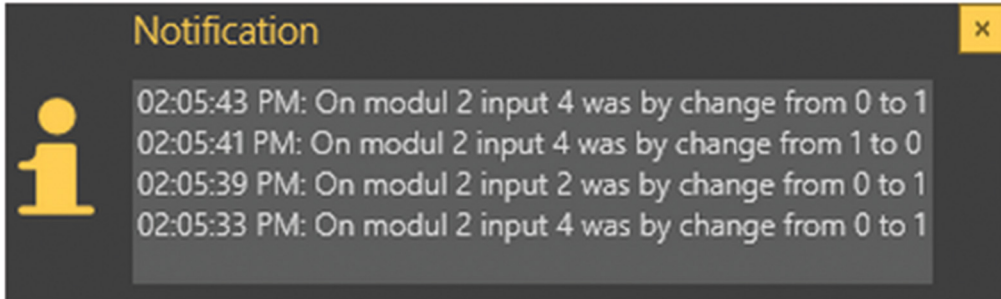

Notification Pop-Up Window

Each I/O module is identified with a number and an overview of inputs and outputs. Use the Configuration / I/O Modules menu to add a brief description to an input/output. This makes it easy to identify which input or output is being used. In the same menu, it is also possible to set the color of the active and inactive I/O status. This makes the visual identification of the state even easier. The logic state of the given object (input/output) is signaled with digits 0/1 in a color ring.

Service Tool for Android

Refer to the 2N TELEKOMUNIKACE official websites, **2N Lift8** download section, for the latest application versions. Use the following [link](#) or Google Play mobile application to view the online manual.

Installation and Licensing

The application is available at [Google Play](#) or 2N TELEKOMUNIKACE web sites, Download of Lift8 products. Use the following [link](#) to the online manual.



TIP

The application can be used for connection of Central Units with FW versions 1.10.0 and higher.



CAUTION

The application can only work on a device that supports the USB Host as it uses USB for CU communication! Otherwise, the CU cannot be connected.



NOTE

The application language is based on the local Android configuration. A language change in the system results in a language change in the application.

Google Play Installation

Use Google Play to install the package. Use your Google Play account for installation. If you do not have your Google Play account, simply create a new one. Now select Google Play in the application list, confirm the license terms and conditions and get access to hundreds of thousands of applications. Google Play provides both free applications as well as paid applications that require a payment card assigned to the Google account. Now a standard procedure can start.

Search and select the application and click Install. A list will get displayed with authorized accesses that the application requires. Confirm the authorizations to make the application get installed. Confirmation will be displayed after a successful installation and you can start the new application. The application will be displayed in the menu and can be used.

Service Tool for Android

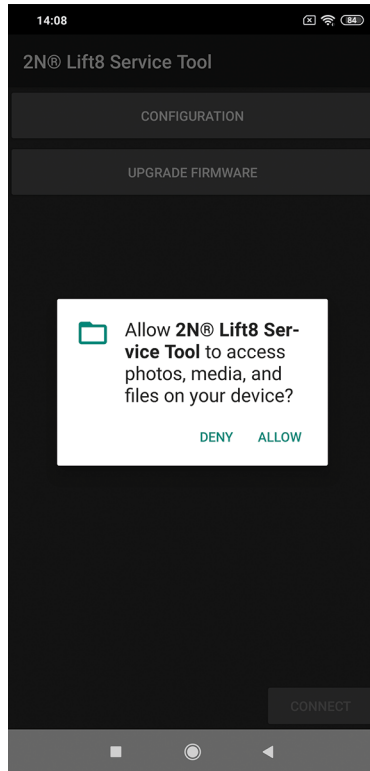

Service Tool Authorization Requirements

If you have a Google account connected with your phone or tablet, you can install the application via the web interface. All you have to do is log in to Google and select Play in the upper toolbar. Or, enter market.android.com or play.google.com/apps into your browser to display your application installations or updates. The web interface allows you to view applications more comfortably. If you like any of the applications, proceed like with a phone. Click Install, confirm authorization, let the application get installed and start using it.

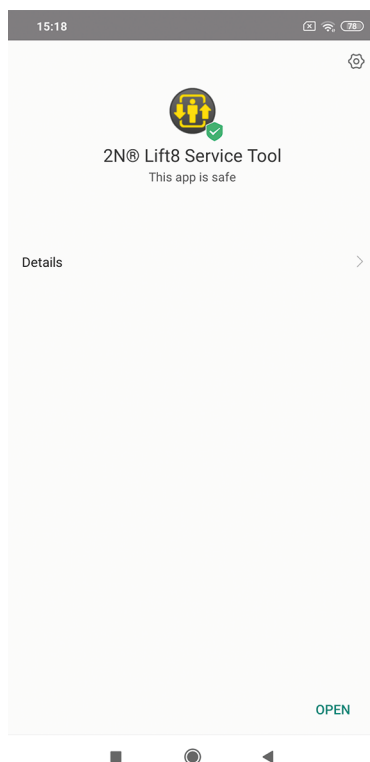

Application Installation Confirmation

.apk Package Installation

You can also download an installation package and install the application manually. APK is an application ending for Android like EXE for Windows. Enable installations from Unknown sources to make this option work. The path is MENU → SETTING → SECURITY → UNKNOWN SOURCES. Select the package in the loaded files or application location and open it using the package installation tool.

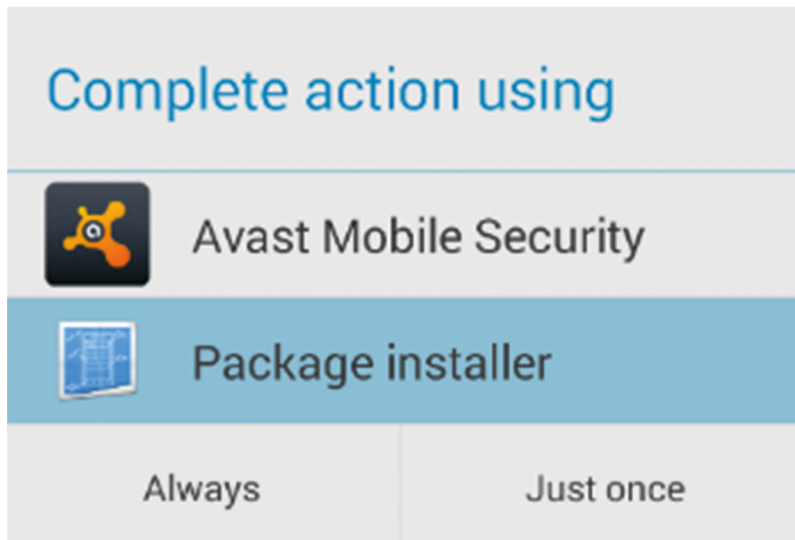

Package Installation Tool

Now the installation proceeds like with Google Play. After installation, the Service Tool icon will be added to the menu. Click the icon to open the application and display the login screen.

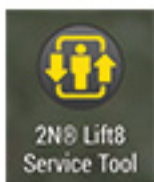

Application Icon in Menu

Central Unit Connection

The USB port driver is installed together with the application. Remember to connect the Central Unit before logging in. To do so, use a USB cable (USB A → USB B) or an appropriate adapter that matches the USB port on your device (MicroUSB A → USB B). After the Service Tool start and CU connection, the "Do you want to open the 2N Lift8 Service Tool when connecting this USB device?" message will be displayed.



CAUTION

- Make sure that your device supports the USB Host standard! Otherwise, the connection to the Central Unit will not work.
- Make sure that your mobile device (SmartPhone/Tablet) supports this function. Refer to the Technical Parameters or the manufacturer's advice for this information.



2N® Lift8 Service Tool

Allow the app 2N® Lift8 Service Tool to access the USB device?

Use by default for this USB device

CANCEL

OK

USB Connection Setting

Use

Central Unit Login

Having launched the application, press Login (right-hand bottom corner) to display the password entering menu. Enter the CU password, which has up to 15 characters.



NOTE

- The CU default password is "2n", unless specified otherwise by the customer. Refer to the CU package for the correct password.
- A window pops up for you to get access to the USB device upon every login.

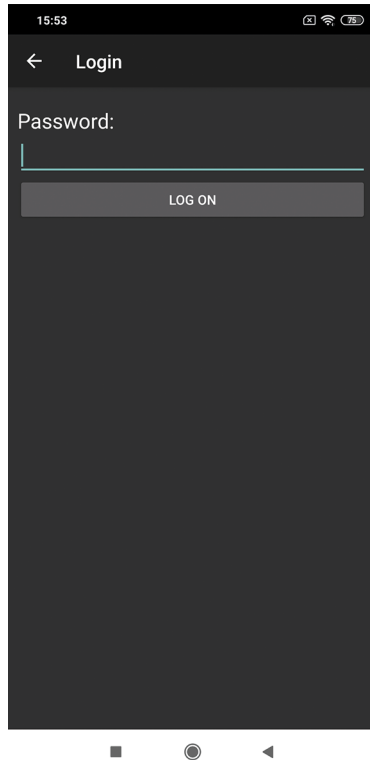

Login Screen

Once you have entered the correct password, click the Login button. The application logs you in to the Central Unit connected. The application warns you of any typing error and allows you to re-enter the password. Upon login, you get into the Main menu and its submenus. The Main menu lists the other available menus. The Configuration and Upgrade menus are only available at present. Other menus known from the 2N Lift8 Service Tool PC application will be available in the future.

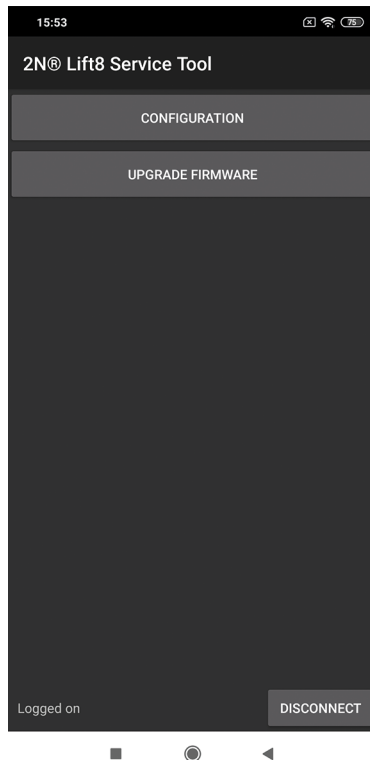

Configuration

Configuration

Click on the menu name, Configuration in this case, to open the corresponding menu. No data is available yet. The informative message Start by Selecting Menu Item is only displayed. Click the pop-down menu in the right-hand upper corner to display five options: New, Open from File, Save to File, Read from Device and Save to Device.



TIP

The control design may be different in different Android versions. Yet, the location and operation of the system control elements are almost the same.

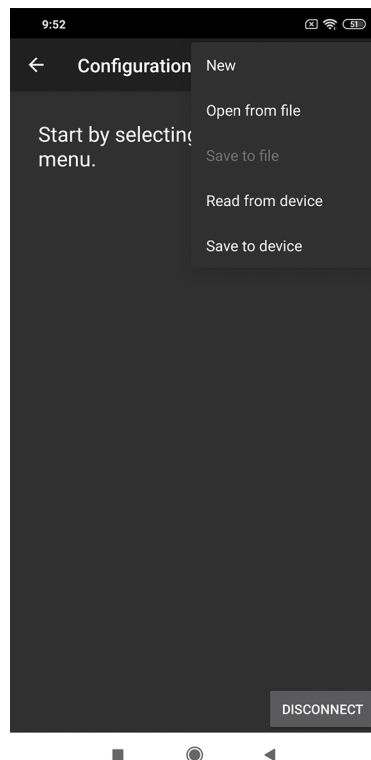

Read Configuration

Open from File – upload configuration from a file (saved on a phone or Google disk).

Save to File – save configuration (read from a phone or Google disk).

Read from Device – read configuration from the Central Unit connected. The “Upload has started” message is displayed at the same time. When the parameter table has been uploaded, a dialog window is displayed to inform you that the configuration has been read successfully.

Save to Device – save configuration to the Central Unit. The “Saving Has Started” message is displayed at the same time. When the parameter table has been saved, a dialog box is displayed to inform you whether the configuration has been saved successfully.

A dialog box is used for confirming that the configuration has been read successfully and that you can view and edit the data. The uploading and saving time depends on your hardware power output. Generally, it only lasts a few seconds. If it takes longer, press the Back button and repeat the action.

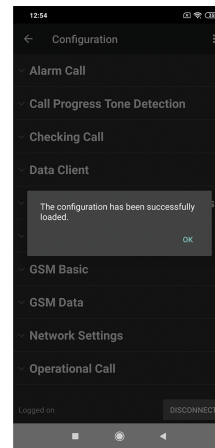
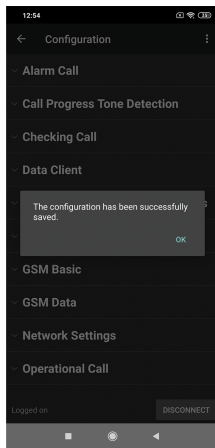

Configuration Download Confirmation

Parameter Editing

When the configuration has been read, parameter blocks are displayed in the alphabetical order like in the PC application. Click the selected block to open the list of related parameters. Every parameter includes a numeric code, name and current value.

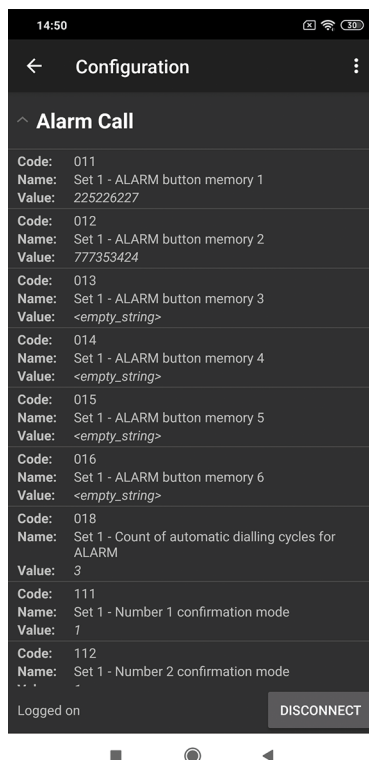

List of Parameters

Click a parameter to change its value. A dialog box opens with the numeric parameter code in the first position. The following is its name and unit. Click the question mark to know the parameter function. You will see a brief description of the function of the parameter. The range of values that the parameter can take is displayed after the unit. The Value parameter defines a new parameter value. If you use numeric or hourly values, you can use the system scroll bar to set the required value. However, we recommend clicking on the value for values with a large range. A keypad will be displayed and the new value can be entered manually. The same applies to string (password) entering. Or, you can use a combobox to modify parameters with pre-defined values.

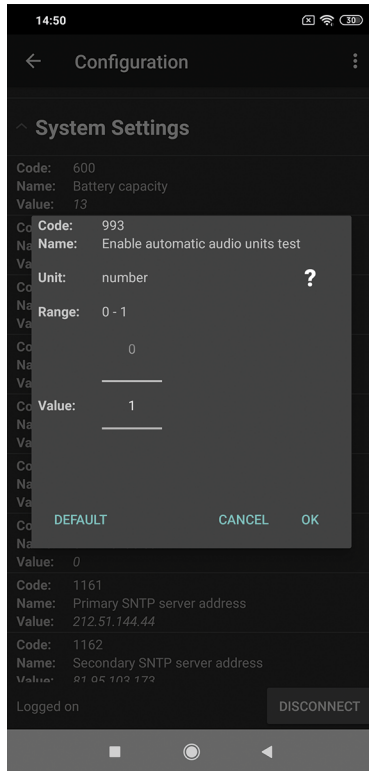

Parameter Settings

There are three controls in the lower part of the dialog box. Click Cancel to quit editing and save the original setting. Click Default to set the default value and OK to confirm the new setting. If you make a typing mistake, for example, set a value beyond the limits or exceed the character limit, you will be warned by the validator, which watches every parameter for correct values.

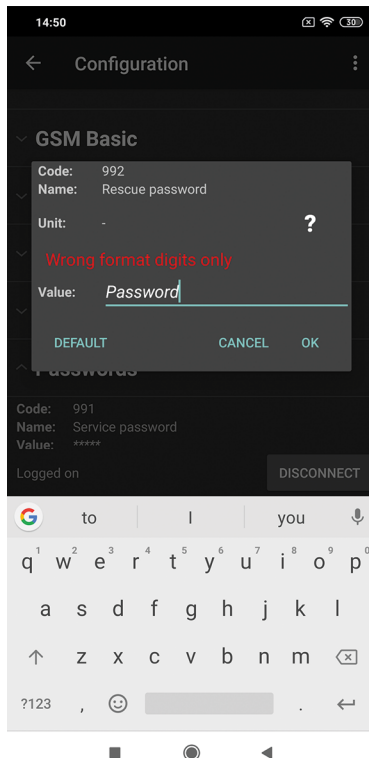

Value Validator Function

If you have set up everything correctly, you can select Save Configuration in the right-hand upper corner of the menu. The application saves the set values to the Central Unit database. Use the system Back button to return to the previous menu. If you click the button, you will be logged out from the Main menu. Quit the application in the standard way. Click the system Home button to quit the application. If you do not need it any more for the time being, press Last Used Programs to terminate the application.

Firmware Upgrade

Click Upgrade firmware to display a menu to select the required firmware and voice menu. While upgrading, you can reset the Central Unit to the factory values using a checkbox. Having pressed Upgrade, wait for the firmware and voice menu to be upgraded. Then a message pops up and the applications disconnects. You cannot reconnect to the CU until the upgrade process has been completed.

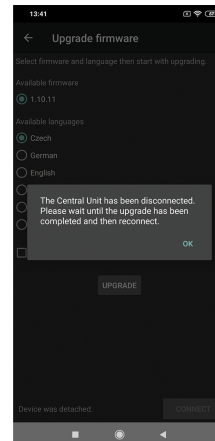
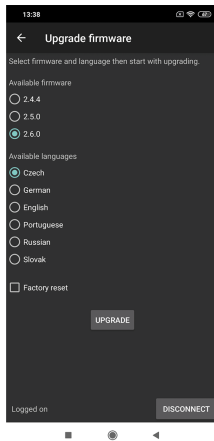

NOTE

Upon connection, the application recognizes the hardware and offers compatible firmware.

Maintenance

Operation Interruption and Battery Replacement

Operation Interruption and Battery Replacement

Disconnection and replacement of battery packs:

1. Disconnect the CU from the mains supply. Remove the top cover (see the previous subsection – CU Electrical Installation – Putting in Operation).
2. Disconnect the battery interconnecting cable (see the figure) to disconnect the backup rechargeable batteries.



3. Disconnect the FASTON terminals of the motherboard - battery connecting cable too to replace the rechargeable batteries.
4. Remove the battery pack holder using a No. 8 spanner.
5. Replace the battery pack and fix the holder again using a No. 8 spanner.
6. Interconnect the rechargeable batteries, but do not connect them to the motherboard.
7. Connect the mains supply and then connect the battery pack to the motherboard using the cables.
8. Replace the upper cover on the CU and tighten the cover fitting screws. Make sure that the grounding wire is connected with the cover while replacing the cover!
9. Click the Reset button to Reset backup battery pack life counter (see Subs. 2.1).



WARNING

- Always disconnect the mains supply before you start installing, maintaining or checking the CU.
- Use only the battery packs supplied or approved by the manufacturer for replacement! If a wrong type is used, the battery pack can start burning or explode or the central unit electronics can get damaged.
- Maintain the battery pack polarity! When the polarity of the batteries is reversed, there is a danger of fire or explosion or damage to the CU electronics.
- Replace both the battery packs in the equipment at the same time, never mix old and new batteries! Make sure that the rechargeable batteries in the device are of the same type and age!
- Expired battery packs contain hazardous chemical substances and have to be disposed of in accordance with the applicable environmental regulations!



WARNING

Accident Risk

- **WARNING!** Live parts are exposed after the CU cover is removed!
- Be very careful and never touch the dangerous live parts!
- Never work with a switched-on CU with its protective cover off unless you are an authorized person duly trained according to Decree 50/1978 Coll.
- Never insert damaged batteries. Do not insert the batteries in the CU that might show electric or mechanical damage.
- Never use **2N Lift8** without its protective cover. There is a risk of electric accident, malfunction due to wrong interconnection and/or **2N Lift8** electronics damage or destruction as a result of electric short-circuit or adverse environmental conditions. It is because **2N Lift8** is not protected against dangerous touch and water – IP00.
- Make sure before installation that the **2N Lift8** board is not damaged!
- Do not connect devices other than the approved ones. Unapproved devices may cause electrical accident or device damage.



CAUTION

- Remember to put the product in operation in time after disconnecting the battery interconnecting cable.
- The product can be stored for a maximum of 1 week without recharging and for 1 month after full charging.
- Never leave the rechargeable batteries flat longer than needed.
- If the battery pack is completely flat, recharge it as soon as possible.
- Remember to replace the batteries every two years to ensure the power outage backup.

Always remember that the state of the batteries is essential for the system operation.

Firmware Upgrade (Update)

The **2N Lift8** upgrade is carried out using the Service Tool. The Service Tool will upgrade the CU and the connected audio units. Alternatively, you can only upgrade the LTE module firmware.

Procedure



CAUTION

Make sure that the SIM card is registered before upgrading the CU with an LTE module. If registration fails, remove the SIM card and upgrade the CU without it. Replace the SIM card after upgrade.

1. Run the Service Tool and connect the CU (USB, TCP).
2. Select the Device – Upgrade menu.
3. Select the desired firmware. The firmware is available depending on the hardware version of the Central Unit connected.
4. Select the voice menu language version.
5. Choose whether you want to keep the configuration or reset the parameters to the factory values (via the checkbox). Factory resetting is only possible when the firmware of the complete Lift8 system is upgraded.
6. Start upgrading.
7. First the new FW is loaded to the CU. The Service Tool will log out from the CU upon the load.
 - a. The first thing to do is to upgrade the CU, which is then rebooted. After CU is restarted, the audio units will start upgrading.
 - b. The yellow and green LEDs flash to indicate audio unit upgrading. Sound signaling indicates a successful upgrade of each audio unit. The audio unit upgrade can take up to several minutes.



CAUTION

Check the device time after upgrade.



TIP

- Back up your configuration, execute upgrade and factory default reset and upload the configuration into the device (new ranges and default values will be used in the new FW version).
- It is recommended that you factory reset the parameters to set new ranges and default values in the new FW version.

Delete All User Data

To delete user data, reset the device to the factory settings. To factory reset the device, choose one of the following options:

Press **RESET**.





1. Press and hold the **RESET** button until all the LEDs shine red.
2. Once the LEDs are red, release the button.
3. Wait until the LED SYSTEM starts flashing yellow.
4. The moment the LED SYSTEM flashes yellow, press **RESET** shortly.
5. The factory defaults will be reset on the device. All the saved data and settings will be deleted.

Service Tool

1. Turn on the Service Tool and connect the CU.
2. Go to Devices > Info.
3. Press Reset Factory Settings in the Maintenance section.

DTMF Programming

Perform a complete system initialization using parameter 899 to delete user data.

1. Make sure that you have the correct service password.
2. To enter the programming mode:
 - a. Dial the L8 phone number.
 - b. Or, press  (for over 2 s) on the machine room audio unit.
3. In the voice menu:
 - a. Press 9 for administration.
 - b. Press 1 for access to the programming menu.
4. Enter the service password and confirm it with an asterisk .
5. If the password is correct, L8 announces: "You have entered the programming menu, select a parameter".
6. In the programming menu: Press 899  service password .

Via SMS

1. Make sure that you have the correct service password.
2. Send a message to the Central Unit phone number in the "L8 DEF service password" format (e.g. "L8 DEF 12345").
3. If everything is OK, you will receive the following confirmation SMS: "L8 DEF OK".

Functionality Tests in Accordance with EN 81-28

This subsection describes the procedures for verifying the functionality of the ALARM emergency signaling system in an elevator with **2N Lift8** according to the EN 81-28 standard requirements. The tests must be carried out before the elevator is put in operation and periodically as a maintenance task.

Preparation

1. Connect the Central Unit **2N Lift8** to the Service Tool application in your PC and note the settings for the following values:

Code / Parameter	Name	Allowed values
914	Delayed Call	≥ 1 s
962	Minimum ALARM press time in cabin	< 3000 ms
963	Minimum button press time for forced/test alarm	3 s
966	Rescue Mode	1 = rescue terminated with button 2, 2 = rescue terminated with password, 3 = rescue terminated with button 2 or password
992	Rescue Password	up to 16 digits: 0–9



CAUTION

Make sure that you have changed the administrator password while logging in to the Service Tool.



TIP

The parameter values can be checked via DTMF.

2. Prepare also the number of the shaft in which the elevator to be tested is located. The shaft number determines the addressing on the splitter. Address 1 is allocated for the shaft connected directly to the Central Unit.

6.2.2 ALARM Emergency Signaling Information (4.1.2)

1. Press and hold the ALARM button with the bell symbol for the time required to trigger the test alarm (min. 30 seconds).
2. Check that the yellow LED lights up and the sound signal is heard.
3. When the call is connected to the rescue service, make sure the green LED starts flashing.
4. Verify the two-way communication with the rescue service.

6.2.3 ALARM Emergency Signaling End (4.1.3)

1. Follow the test steps for [6.2.2 ALARM Emergency Signaling Information \(4.1.2\)](#) (p. 250).
2. Ask the rescue service to end the call.
3. Check that the green LED stops lighting when the call is ended. The yellow LED remains on.

4. Exit the rescue mode.

Exit with button 2

- a. Press button 2 for 3 seconds.

Button 2 is an external button plugged into the audio unit connector marked as ALARM 2; the location being determined by the installing company.

Exit by entering password

- a. Call **2N Lift8** – dial **2N Lift8** .



TIP

You can also press and hold the asterisk on the Machine Room audio unit (for at least 2 seconds).

- b. Press DTMF 9 to enter administration.
 - c. Press DTMF 2 to end the rescue.
 - d. Press the number of the shaft (1 - 8) in which the head is located.
 - e. Enter the rescue password and press an asterisk for confirmation.
5. Check that the yellow LED has gone off.













6.2.4 Emergency Power Supply (CU) (4.1.4) – Lift8

1. Disconnect the Central Unit (CU) power cable from the 230 V socket.
2. Verify the functionality of the ALARM signaling by following the instructions in [6.2.2 ALARM Emergency Signaling Information \(4.1.2\) \(p. 250\)](#) and [6.2.3 ALARM Emergency Signaling End \(4.1.3\) \(p. 250\)](#).
The ALARM function must work in the same way even if the Central Unit is powered by an emergency supply.
3. Disconnect the device from the emergency power supply (battery pack in the CU).
 - a. Loosen the three screws on the upper cover of the CU.
 - b. Move the upper cover of the CU in such a way that you can remove it.
 - c. Proceed with caution while removing the cover, be careful about the grounding wire connecting the cover with the CU bottom part. Do not disconnect the cable if possible!
 - d. Disconnect the FASTON cable from the motherboard.
4. Plug the CU power cable into a 230 V socket.
5. Check the LED indicators on the Central Unit – the POWER/BATTERY LED should shine red when the emergency supply is disconnected.
6. Reconnect the battery pack with the motherboard using the FASTON cable after the test. Keep the wiring polarity.
7. Replace the upper cover on the CU and tighten the cover fitting screws. Make sure that the grounding wire is connected with the cover while replacing the cover!
8. Make sure that the red BATTERY/POWER LED is not shining.

6.2.5 Visual and Acoustic Signals in Elevator Cage (4.1.5)

For some audio units, the external LEDs are led out into the elevator cabin. The installing company is responsible for their placement. Check that the external LEDs are led into the elevator cabin.

Maintenance

Audio unit	Connecting call	Active call	Active rescue mode	Rescue mode end
918618BE, 2N Lift8 – Audio Unit Flush, With button	Yellow LED + sound signal	Yellow LED + green LED flashing	Yellow LED	No LED is on
918618E, 2N Lift8 – Audio Unit Flush, Without button	Yellow LED + sound signal	Yellow LED  + green LED flashing 	Yellow LED	No LED is on
918618BE, 2N Lift8 – Audio Unit Compact, With button	Yellow LED  + sound signal + button flashing	Yellow LED  + green LED flashing  + button flashing	Yellow LED  + button backlight flashing	No LED is on
918613WBE, 2N Lift8 – Audio Unit Compact, Without button	Yellow LED + sound signal	Yellow LED  + green LED flashing 	Yellow LED	No LED is on
918611E 2N – Machine room audio unit – machine room/control room	Yellow LED + sound signal	Yellow LED  + green LED flashing 	Yellow LED	No LED is on
918612E, 2N Lift8 – Audio Unit Shaft – shaft	Yellow LED + sound signal	Yellow LED  + green LED flashing 	n/a	n/a
918618EE, 2N, Lift8 Audio Unit, Landing (Evac.), for flushed mount installation 918619E22N, Lift8 MEEF (Evac.), for flushed mount	Yellow LED + sound signal	Green LED flashing 	n/a	n/a
918615E, 2N Lift8 – Audio Unit Fireman, Key & PT	No signaling	Blue button backlight	n/a	n/a

6.2.6 Communication (4.1.8), ALARM Emergency Signaling Verification (4.1.6), Identification (4.1.7)

Communication Response

1. Make sure that the elevator door is not fully open.
2. Press the ALARM button with the bell symbol for the ALARM button press time (parameter 962).
3. Check that the yellow LED lights up and the sound signal is heard.
4. When the call is connected to the rescue service, make sure the green LED starts flashing.
5. Verify the two-way communication with the rescue service.

ALARM Verification and Restart

1. Make sure that the elevator door is not fully open.
2. Press the ALARM button with the bell symbol for the ALARM button press time (parameter 962).
3. Check that the yellow LED lights up and the sound signal is heard.
4. When the call is connected to the rescue service, make sure the green LED starts flashing.
5. Verify the two-way communication with the rescue service.
6. Ask the rescue service to end the call.
7. Check that the green LED stops lighting when the call is ended. The yellow LED remains on.
8. Press the ALARM button shortly.
9. Make sure that an audio signal sounds to indicate that the call is being connected. The system must establish connection immediately after the short press.
10. When the call is connected to the rescue service, make sure the green LED starts flashing.

It is necessary to verify on the receiving side that the device is correctly identified on the receiving device. The receiving device is not in the **2N Lift8** portfolio.

Accessibility and Reliability (4.2.1)

The communication in the event of unavailability of the main receiving device and automatic test records (operational calls) need to be verified at the receiving device. The receiving device is not in the **2N Lift8** portfolio.

Technical Parameters

Central Unit

- Power supply: 100–240 V; 50/60 Hz; 0.75 A; 60 W max.
- Power supply backup: 1.3 Ah / 3 Ah Internal Lead Acid Battery
- Capacity: 8 audio units
- Maximum distance between CU and last splitter: 30 m with the cross-section of 0.75 mm² (60 m – 1.5 mm² , or 100 m – 2.5 mm²)
- Interface for connection with the elevator service room: PSTN / LTE / VoIP / Ethernet
- Configuration and monitoring: Voice menu / USB / remote
- Indicators: 5 LEDs, three-color
- Elevator blocking output: relay, both NO and NC contacts
- Dimensions: 300 x 170 x 72 mm
- Weight: 2.7 kg

Splitter

- Power Supply: 24 V from Central Unit or local
- Capacity: 8 audio units
- Maximum total cable length in shaft: 600m
- Elevator blocking output: relay, both NO and NC contacts
- Dimensions: 142 x 98 x 34 mm

I/O module

- Power Supply: 24 V from Central Unit or local
- Capacity: 4 inputs + 4 outputs
- Inputs: galvanically isolated AC or DC
- Outputs: relay, NO contacts, up to 250 V, 5 A
- Dimensions: 142 x 98 x 34 mm

LTE/UMTS/GSM Module

- Operating temperature: –40 °C to 85 °C
- Dimensions: 29.0 × 32.0 × 2.4 mm
- Weight: approx. 4.9 g
- Supply voltage: 3.3–4.3 V (typ. 3.8 V)
- Standard: 3GPP E-UTRA Release 11
- Bandwidth: 1.4 / 3 / 5 / 10 / 15 / 20 MHz
- Supported bands:
 - LTE FDD: B1/B2/B3/B4/B5/B7/B8/B12/B13/B18/B19/B20/B25/B26/B28
 - LTE TDD: B38/B39/B40/B41
 - UMTS: B1/B2/B4/B5/B6/B8/B19
 - GSM: B2/B3/B5/B8
- Maximum rates:
 - LTE FDD: 150 Mbps (DL) / 50 Mbps (UL)
 - LTE TDD: 130 Mbps (DL) / 30 Mbps (UL)
 - UMTS: DC-HSDPA 42 Mbps (DL), HSUPA 5.76 Mbps (UL)
 - GSM: EDGE 296 kbps (DL) / 236.8 kbps (UL), GPRS 107 kbps (DL) / 85.6 kbps (UL)

Fireman (918615E)

Technical Parameters

- Cover: robust aluminum cast product
- Operating temperature: -25 °C to 55 °C
- Working relative humidity: 10 to 95 % non-condensing
- System storage temperature: -40 °C to +70 °C
- Dimensions: (217 x 109 x 83) mm, (242 x 136 x 83) mm incl. frame
- Weight: net max. 2 kg / gross max. 2.5 kg
- Covering level: IP65

Audio Unit – Shaft Anti-Vandal

- Cover: robust aluminum cast product
- Operating temperature: -25 °C to 55 °C
- Working relative humidity: 10 to 95 % non-condensing
- Storage temperature: -40 °C to +70 °C
- Dimensions: (217 x 109 x 83) mm, (242 x 136 x 83) mm incl. frame
- Weight: net max. 2 kg / gross max. 2.5 kg
- IP rating: IP65

Telephone Parameters (PSTN)

Parameter	Value	Conditions
Minimum line current	15 mA	off-hook
Minimum line voltage	22 V	on-hook
Off-hook DC voltage drop	< 8 V < 16 V	I = 25 mA I = 50 mA
On-hook resistance	>1 MΩ	U = 25..100 V
Off-hook impedance	220 Ω + 820 Ω paral. 115 nF	20 to 60 mA
Return loss	> 14 dB	20 to 60 mA
Bandwidth	300 to 3500 Hz	20 to 60 mA
Ring impedance	> 2 kΩC = 1 μF	25 to 50 Hz
Ring detector sensitivity	10 to 20 V	25 to 50 Hz
Pulse dialing	40 / 60 ms	
Tone dialing level	6 and 8 dB ± 2 dB	20 to 60 mA

Technical Parameters

Parameter	Value	Conditions
Dial-tone detector sensitivity	approx. 43 dB	(note 2)
Overvoltage protection – between A, B	1000 V	8 / 20 µs



NOTE

- All the product parameters comply with TBR-21 on condition that the product is to be operated as a single line terminal, i.e. no parallel connection with any other equipment is allowed.
- Line interference and noise picked up by the L8 microphone are relevant factors.

Other Parameters

Unit type

- 918600, Central Unit: 300 x 170 x 72 mm
- 918610E(XE), Audio Unit – Cabin, universal: 65 x 130 x 22 mm
- 918611E, Audio unit – Machine room: 225 x 87 x 67 mm
- 918612E, Audio unit – Shaft: 225 x 87 x 67 mm
- 918613E, Audio unit – Compact: 185 x 100 x 22 mm
- 918620E, Splitter: 142 x 98 x 34 mm
- 918621E, I/O Module: 142 x 98 x 34 mm
- 918622E, Camera Module: 142 x 98 x 34 mm
- Range of operating temperatures: 0–40 °C

The manufacturer reserves the right to modify the product in order to improve its qualities.

The product contains no environmentally harmful components. When the product's service life is exhausted, dispose of it in accordance with the applicable legal regulations.

Supplementary Information

Troubleshooting



NOTE

Refer to <https://www.2n.com/faqs> for the most frequently solved problems.

General Recommendations

- Always use the latest available firmware version to ensure the maximum operational security.
- A separate cable is recommended for each audio unit in a high-interference environment

Most Common Configuration Errors

- Use unique administrator and service passwords for each Central Unit. Do not use the same password for multiple devices to avoid compromising the security of installations.
- If you cannot save the values during configuration, make sure that the administrator password is set.
- If you notice a problem with DTMF transmission via GSM, change parameter 710 to 1.

SIP Error Codes

SIP Registration Error Codes

Code	Designation	Description
10	SIP_ERR_REGISTER_SERVER_ADDR_RE-SOLVE	Failed to translate the SIP server address.
11	SIP_ERR_REGISTER	General error
12	SIP_ERR_REGISTER_FORBIDDEN_ACCESS	Access denied
13	SIP_ERR_REGISTER_RCVTIMEOUT	The server response timeout has expired.

Call Setup Error Codes (Invite)

Code	Designation	Description
20	SIP_ERR_INVITE_ADDR_RESOLVE	Failed to translate caller address.
21	SIP_ERR_INVITE	General Call Setup Error
22	SIP_ERR_INVITE_USER_NOTFOUND	User not found (SIP 404).
23	SIP_ERR_INVITE_FORBIDDEN_ACCESS	Access denied
24	SIP_ERR_INVITE_RCVTIMEOUT	The INVITE response timeout has expired.

In the event of the `SIP_ERR_INVITE_RCVTIMEOUT` error (24), the device provides an additional status code specifying at which SIP process stage the timeout expired. This provides a more accurate diagnosis of the problem.

Registration Process States

- 0 = SIPCON_STATE_UNREGISTERED
- 1 = SIPCON_STATE_REGISTER_AFTER_IPADDR_RESOLVED
- 2 = SIPCON_STATE_REGISTER
- 3 = SIPCON_STATE_REGISTERING
- 4 = SIPCON_STATE_REGISTERED
- 5 = SIPCON_STATE_UNREGISTER
- 6 = SIPCON_STATE_UNREGISTERING

Call Process States

- 100 = SIPCON_STATE_NOINVITED
- 101 = SIPCON_STATE_INVITE_AFTER_IPADDR_RESOLVED
- 102 = SIPCON_STATE_INVITE
- 103 = SIPCON_STATE_INVITING
- 104 = SIPCON_STATE_INVPENDING
- 105 = SIPCON_STATE_RINGING
- 106 = SIPCON_STATE_INVITED
- 107 = SIPCON_STATE_HANGUP
- 108 = SIPCON_STATE_HANGUPING
- 109 = SIPCON_STATE_DECLINE
- 111 = SIPCON_STATE_INCOMING_INVITE
- 112 = SIPCON_STATE_INCOMING_ACCEPT
- 113 = SIPCON_STATE_INCOMING_ACCEPTING
- 114 = SIPCON_STATE_INCOMING_DECLINE
- 115 = SIPCON_STATE_REINVITE
- 116 = SIPCON_STATE_REINVITENING
- 117 = SIPCON_STATE_REINVPENDING

List of Abbreviations

L8	2N Lift8
CU	System Central Unit, typically shared by multiple elevators in one building.
Splitter	Interconnects the audio units with the CU. Each elevator shaft has a splitter of its own.
Audio Unit	Audio unit used for voice communication with the control room or another system unit.
System	Central Unit interconnected with a splitter and group of audio units.
Main Bus	6 wires (power, audio, data) connecting the CU with splitters.
Bus	Double wire interconnecting the splitter with the elevator audio units.
Incoming Call	Call from the control room to the CU.
Outgoing Call	Call from the CU to the control room.
Checking Call	A call from the CU to the checking call line registered in 2N Lift8 Server or another number defined.
Triphony	Inter-audio unit communication, typically between all the audio units of one elevator, during repairs or rescue operations, for example.
Control Room	Workplace receiving alarm calls. There can also be separate workplaces for various call types or just the staff mobile telephones.
DISA	Automatic voice menu for incoming call routing to the required audio unit or function activation, e.g. remote programming.
PBX	Private branch exchange (equipped with PSTN connection and analog local lines).
PSTN	Public telephone network. For simplicity, it is assumed that the CU is connected to the PSTN but works identically on the PBX line too.

L8	2N Lift8
GSM	Global System for Mobile Communications
UMTS	Universal Mobile Telecommunication System.
UDP	User Datagram Protocol is one of basic protocols of the Internet protocol set.
TCP	Transmission Control Protocol is one of the set of Internet protocols.
ST	The 2N Service Tool application is intended for remote supervision and configuration of the 2N Lift8 communicators.
CP	The 2N Control Panel application is intended for administration of users, elevators and authorizations.
CM (Comm)	The 2N Communicator application is intended for receiving alarm calls by the control room.
SRV	The 2N Server application processes the checking calls and mediates communication between the CUs and PC applications.
Validator	This code monitors the values entered in the applications, and in the event of an error such as excessive length, forbidden character, incorrect format etc., warns the user.

Regulations

2N Lift8 conforms to the following directives and regulations:

- 2014/35/EU for electrical equipment designed for use within certain voltage limits
- 2014/30/EU for electromagnetic compatibility
- 2014/33/EU for elevators and safety components for lifts
- 2011/65/EU on the restriction of the use of certain hazardous substances in electrical and electronic equipment
- 2012/19/EU on waste electrical and electronic equipment

European Parliament and Council Directive 95/16/EC of 29 June 1995 on the approximation of the laws of the Member States related to lifts

Directive 2014/33/EU of the European Parliament and Council Directive of 26 February, 2014 on the harmonization of the laws of the Member States relating to elevators and safety components for lifts

Government Regulation No 27/2003 Coll. of 9 December 2002 laying down technical requirements for elevators

ČSN EN 81-28

ČSN EN 81-72

General Instructions and Cautions

Please read this User Manual carefully before using the product and follow the instructions and recommendations included therein.

Any use of the product that is in contradiction with the instructions provided herein may result in malfunction, damage or destruction of the product.

The manufacturer shall not be liable and responsible for any damage incurred as a result of a use of the product other than that included herein, namely undue application and disobedience of the recommendations and warnings.

Any use or connection of the product other than those included herein shall be considered undue and the manufacturer shall not be liable for any consequences arisen as a result of such misconduct.

Moreover, the manufacturer shall not be liable for any damage or destruction of the product incurred as a result of misplacement, incompetent installation and/or undue operation and use of the product in contradiction herewith.

The manufacturer assumes no responsibility for any malfunction, damage or destruction of the product caused by incompetent replacement of parts or due to the use of reproduction parts or components.

The manufacturer shall not be liable and responsible for any loss or damage incurred as a result of a natural disaster or any other unfavorable natural condition.

The manufacturer shall not be held liable for any damage of the product arising during the shipping thereof.

The manufacturer shall not make any warrant with regard to data loss or damage.

The manufacturer shall not be liable and responsible for any direct or indirect damage incurred as a result of a use of the product in contradiction herewith or a failure of the product due to a use in contradiction herewith.

All applicable legal regulations concerning the product installation and use as well as provisions of technical standards on electric installations have to be obeyed. The manufacturer shall not be liable and responsible for damage or destruction of the product or damage incurred by the consumer in case the product is used and handled contrary to the said regulations and provisions.

The consumer shall, at its own expense, procure software protection of the product. The manufacturer shall not be held liable for any damage incurred as a result of the use of deficient security software.

The consumer shall, without delay, change the access password for the product after installation. The manufacturer shall not be held liable or responsible for any damage incurred in connection with the use of the original password.

The manufacturer also assumes no responsibility for additional costs incurred by the consumer as a result of making calls to increased tariff lines.

Decommissioning and Environmental Disposal

Before decommissioning the device, it is necessary to reset the device to factory settings to completely remove all configuration data and stored contacts. Follow the instructions in [Delete all user data \(p. 248\)](#).

Electric Waste and Used Battery Pack Handling



Do not place used electric devices and battery packs into municipal waste containers. An undue disposal thereof might impair the environment!

Supplementary Information

Deliver your expired household electric appliances and battery packs removed from them to dedicated dumpsites or containers or give them back to the dealer or manufacturer for environmental-friendly disposal. The dealer or manufacturer shall take the product back free of charge and without requiring another purchase. Make sure that the devices to be disposed of are complete.

Do not throw battery packs into fire. Battery packs may not be taken into parts or short-circuited either.



2N Lift8 – User Manual

© 2N Telekomunikace a. s., 2026

2N.com