



2N IP Verso

Installation Manual



Table of Contents

Symbols and Terms Used	4
Product Description	5
Basic Features	5
Product Versions	6
Accessories	8
Accessories for Installation	8
Frames	11
Extenders	14
Power Supply	28
Licenses	29
Other accessories	29
Package Completeness Check	35
Module / Frame Package Completeness Check	36
Installation	37
Mechanical Installation	37
Installation Conditions	37
Flush mounting	39
Surface Installation	81
Stand Installation	101
Electric Installation	103
Power Supply	103
Power Supply Installation	104
Device Connectors	105
LAN Connection	109
Overvoltage Protection	110
Installation Completion	112
Frame Attachment	113
Most Frequent Installation Errors	113
Name Tags	114
Nametag Insertion/Replacement	115
Tactile stickers	115
Main and Extending Modules	116
Module Interconnection	116
Module Power Supply	118
Module Specifications	122
125 kHz RFID Card Reader Module	122
13.56 MHz, NFC RFID Card Reader Module	123
Secured 13.56 MHz NFC RFID Card Reader Module	123
Bluetooth & 125 kHz, 13.56 MHz, NFC RFID Card Reader Module	124
Bluetooth & 125 kHz, secured 13.56 MHz, NFC RFID Card Reader Module	124
Touch Keypad & 125 kHz, 13.56 MHz, NFC RFID Card Reader Module	125
Touch Keypad & 125 kHz, secured 13.56 MHz, NFC RFID Card Reader Module	125
Touch Keypad & Bluetooth & 125 kHz, 13.56 MHz, NFC RFID Card Reader Module	126
Touch Keypad & Bluetooth & 125 kHz, secured 13.56 MHz, NFC RFID Card Reader Module	127
Biometric Fingerprint Reader Module	127
Touch Display Module	128
5-Button Module	129
Keypad Module	129
I/O Module	129
Wiegand Module	131
Security Relay	135
Tamper Switch Module	137
OSDP Module	139

Induction Loop Module	143
Infopanel Module	143
Blind Panel Module	144
Brief Guidelines	145
Device Configuration Interface Access	145
Domain Name	145
IP address	145
Web Configuration Interface Login	145
Configuration via Hardware	146
Device Restart	146
IP Address Retrieval Using Hardware	146
Dynamic/Static IP Address Switching	147
Dynamic IP Address Setting	147
Factory Default Reset	148
IP Address Retrieval	148
IP Address Retrieval Using 2N Network Scanner	148
IP Address Retrieval Using Hardware	150
IP Address Retrieval Using Speed Dial Button	150
Dynamic/Static IP Address Switching and Network Parameter Reset	151
Firmware Update	151
Device Restart	151
Restart Using RESET Button	152
Restart Using Web Configuration Interface	152
Dynamic/Static IP Address Switching	152
Dynamic IP Address Setting	152
Factory Default Reset	153
Factory Default Reset	153
Device Control	154
LED pictograms	156
Colour Signalling	157
Maintenance - Cleaning	158
Troubleshooting	159
Technical Parameters	160
General Instructions and Cautions	167
Directives, Laws and Regulations	167
EU	167
Industry Canada	168
Compliance with DDA:	168
Electric Waste and Used Battery Pack Handling	168

Symbols and Terms Used

The following symbols and pictograms are used in the manual:



DANGER

Always abide by this information to prevent persons from injury.



WARNING

Always abide by this information to prevent damage to the device.



CAUTION

Important information for system functionality.



TIP

Useful information for quick and efficient functionality.



NOTE

Routines or advice for efficient use of the device.

Product Description

In this section, we introduce the **2N IP Verso** product, outline its application options and highlight the advantages following from its use.

Basic Features

2N IP Verso is an elegant and reliable IP intercom equipped with HD camera, which can be assembled exactly according to your needs thanks its modularity. It ensures reliable control of the entrance to the building and allows you to easily connect with other systems, thus achieving even greater security of the building. Thanks to SIP support and compatibility with major IP PBX and phone manufacturers, it can benefit from using VoIP networks.

The device can be used as a door or special purpose intercom for office buildings, residential areas and/or other applications.

The device is a modular system, allowing the user to choose a configuration that perfectly meets their individual needs. Unlike other intercoms, **2N IP Verso** is not delivered as a compact unit. After choosing the installation mode and particular modules, the user gets separate parts to be assembled using the plug&play connections. This approach allows for unique individual combinations and also leaves space for adding of additional modules later on.

The main advantages of this device are:

Wide Angle Camera with HD Resolution – the calling persons can be displayed to the called user on the 2N answering units, the user phone or PC. The camera is elegantly hidden behind darkened glass, so it is not visible. The device is also equipped with a night vision system, which automatically selects the night/day mode according to the ambient light.

Speed Dial Buttons – the device can be equipped with a button module with up to 146 buttons. You can set up to three telephone numbers and call time profiles for each of the buttons to make the called user accessible any time. The buttons are backlit with a clear mechanical response and backlit metal finger pad. The nametag surface is resistant to mechanical damage.

Keypad – the device can be equipped with a numeric keypad module, which allows the user to use the device as a code lock for lock switch activation and/or dialing a defined phone number or user number.

Card Reader – the device can be equipped with a card reader module, which provides access control functionality based on RFID cards or chips. With additional software features, functions other than the door lock can be RFID card controlled too.

Electric Lock Switch – this switch can be controlled via a numeric keypad, PC application or any phone during a call. If necessary, more modules with required outputs can be added. A wide range of switch settings allows for a variety of applications.

Robustness – the device is designed as a robust, mechanically resistant intercom, which withstands weather conditions without needing extra accessories.

Audio Quality – thanks to the integrated acoustic echo cancellation (AEC) system, full duplex communication provides bilateral audibility even when the calling users are speaking at the same time.

Device Installation – is very easy. All you have to do is assemble the required modules and connect the assembly to your LAN with a network cable. The modules are plug&play, so there is no need to configure them manually. The device can be supplied either from a 12 V DC power source or using PoE if supported by your LAN.

Device Configuration – use a PC equipped with any Internet browser for configuration. Extensive installations can be easily managed in bulk using **2N Access Commander**.

Other advantages of the device

Product Versions



CAUTION

If combined with RFID readers, **2N IP Verso** fails to meet the conditions of a supplementary regulation to the EU Radio Equipment Directive – effective from August 1, 2025. **2N IP Verso 2.0** meets the conditions.

Refer to [Impacts of the EU Radio Equipment Directive](#) for more details.



Part No. 9155101

Axis Part No. 01271-001

Main unit 2N IP Verso

There must be just one main unit (with/without a camera) in every installation. The main unit installation requires two frame/box positions one of which is left for installation of an extending module.

One blind module is supplied with the main unit.

Product Description



Part No. 9155101B

Axis Part No. 01272-001

Main unit 2N IP Verso – black

There must be just one main unit (with/without a camera) in every installation. The main unit installation requires two frame/box positions one of which is left for installation of an extending module.

One blind module is supplied with the main unit.

We do not recommend installation in places exposed to direct sunlight.



Part No. 9155101C

Axis Part No. 01273-001

Main unit 2N IP Verso with camera

There must be just one main unit (with/without a camera) in every installation. The main unit installation requires two frame/box positions one of which is left for installation of an extending module.

The main units includes an HD camera.

One blind module is supplied with each main unit.

Product Description



Part No. 9155101CB

Axis Part No. 01274-001

Main unit 2N IP Verso with camera – black

There must be just one main unit (with/without a camera) in every installation. The main unit installation requires two frame/box positions one of which is left for installation of an extending module.

The main units includes an HD camera.

One blind module is supplied with each main unit.

We do not recommend installation in places exposed to direct sunlight.

Accessories

Accessories for Installation

2N IP Verso is designed for both outdoor and indoor applications and requires no additional roof.

Choose the proper frame and, if necessary, other accessories for your particular installation needs.

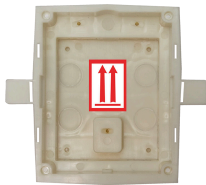

Part No. 9155014

Axis Part No. 01284-001

Flush mounting box, 1-module

The box is designed for brick/plasterboard flush mounting of 1-module.

Delivered including accessories for multiple box assemblies.

Remember to order it together with a 1-module flush mounting frame (9155011/9155011B, 01278-001/01279-001).

Product Description



Part No. 9155015

Axis Part No. 01285-001

Flush mounting box, 2-module

The box is designed for brick/plasterboard flush mounting of 2-module.

Delivered including accessories for multiple box assemblies.

Remember to order it together with a 2-module flush mounting frame (9155012/9155012B, 01280-001/01281-001).



Part No. 9155016

Axis Part No. 01286-001

Flush mounting box, 3-module

The box is designed for brick/plasterboard flush mounting of 3-module.

Delivered including accessories for multiple box assemblies.

Remember to order it together with a 3-module flush mounting frame (9155013/9155013B, 01282-001/01283-001).

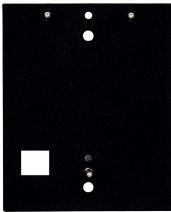

Part No. 9155061

Axis Part No. 01293-001

1-module mounting backplate

Mounting backplate for glass/uneven surface mounting of 1 module.



Part No. 9155062

Axis Part No. 01294-001

2-module mounting backplate

Mounting backplate for glass/uneven surface mounting of 2 modules.



Part No. 9155063

Axis Part No. 01295-001

3-module mounting backplate

Mounting backplate for glass/uneven surface mounting of 3 modules.

Product Description

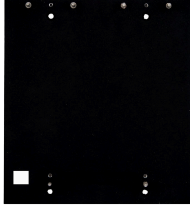

Part No. 9155064

Axis Part No. 01296-001

2 x 2-module mounting backplate

Mounting backplate for glass/uneven surface mounting of 2 (w) x 2 (h) modules.

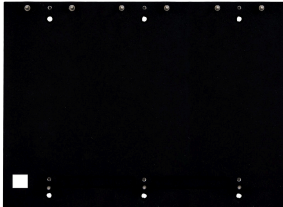

Part No. 9155065

Axis Part No. 01297-001

3 x 2-module mounting backplate

Mounting backplate for glass/uneven surface mounting of 3 (w) x 2 (h) modules.



Part No. 9155066

Axis Part No. 01298-001

2 x 3-module mounting backplate

Mounting backplate for glass/uneven surface mounting of 2 (w) x 3 (h) modules.

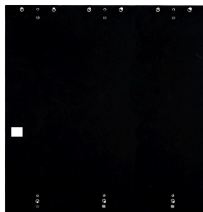

Part No. 9155067

Axis Part No. 01299-001

3 x 3-module mounting backplate

Mounting backplate for glass/uneven surface mounting of 3 (w) x 3 (h) modules.



Part No. 9155072

Axis Part No. 01940-001

2-module slope board

The 2-module slope board is used as a backplate for installations with a tilt of 25°.

Product Description



Part No. 9155050/9155054/9155055

Axis Part No. 01267-001/01268-001/01269-001

1/3/5 m interconnecting cable

Interconnection cable for distant module installation.

Only one interconnecting cable is allowed per installation.

The maximum bus length is 7 m.



Part No. 9155010

Axis Part No. 03343-001

2N IP Verso – Mounting cover for stand

Mounting cover for the 2N IP Verso device for installation on a stand.

Frames

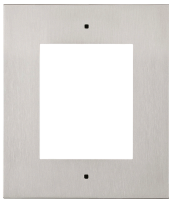

Part No. 9155011

Axis Part No. 01278-001

Flush mounting frame, 1 module

Covering frame for the 1-module brick/plasterboard flush mounting box.

The 1-module frame is used, for example:

- When an additional module is added to an existing installation.
- When the module is mounted onto an extended interconnecting cable, for an OUT card reader, for example.

Remember to order the frame when you order a 1-module flush mounting box (9155014, 01284-001)



Part No. 9155011B

Axis Part No. 01279-001

Flush mounting frame, 1 module – black

Covering frame for the 1-module brick/plasterboard flush mounting box.

The 1-module frame is used, for example:

- When an additional module is added to an existing installation.
- When the module is mounted onto an extended interconnecting cable, for an OUT card reader, for example.

Remember to order the frame when you order a 1-module flush mounting box (9155014, 01284-001)



Part No. 9155012

Axis Part No. 01280-001

Flush mounting frame, 2 modules

Covering frame for the 2-module brick/plasterboard flush mounting box.

Remember to order the frame when you order a 2-module flush mounting box (9155015, 01285-001).



Part No. 9155012B

Axis Part No. 01281-001

Flush mounting frame, 2 modules – black

Covering frame for the 2-module brick/plasterboard flush mounting box.

Remember to order the frame when you order a 2-module flush mounting box (9155015, 01285-001).



Part No. 9155013

Axis Part No. 01282-001

Flush mounting frame, 3 modules

Covering frame for the 3-module brick/plasterboard flush mounting box.

Remember to order the frame when you order a 3-module flush mounting box (9155016, 01286-001).



Part No. 9155013B

Axis Part No. 01283-001

Flush mounting frame, 3-module – black

Covering frame for the 3-module brick/plasterboard flush mounting box.

Remember to order the frame when you order a 3-module flush mounting box (9155016, 01286-001).

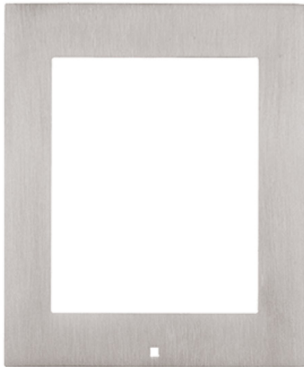

Part No. 9155021

Axis Part No. 01287-001

Surface mounting frame, 1 module

The 1-module frame is used, for example:

- when an additional module is added to an existing installation,
- when the module is mounted onto an extended interconnecting cable, for an OUT card reader, for example.

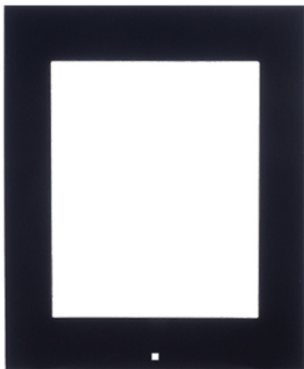

Part No. 9155021B

Axis Part No. 01288-001

Surface mounting frame, 1 module – black

The 1-module frame is used, for example:

- when an additional module is added to an existing installation,
- when the module is mounted onto an extended interconnecting cable, for an OUT card reader, for example.



Part No. 9155022

Axis Part No. 01289-001

Surface mounting frame, 2 modules



Part No. 9155022B

Axis Part No. 01290-001

Surface mounting frame, 2 modules – black

Product Description



Part No. 9155023

Axis Part No. 01291-001

Surface mounting frame, 3 modules



Part No. 9155023B

Axis Part No. 01292-001

Surface mounting frame, 3 modules – black

Extenders



Part No. 9155030

Axis Part No. 01252-001

2N IP Verso – Infopanel

The Infopanel module helps you place such information into the device installation as house number, opening hours and similar data.

The Infopanel backlight is software controlled.



Part No. 9155031

Axis Part No. 01253-001

2N IP Verso – Keypad

The numeric keypad module helps you dial users via their phonebook positions or phone numbers. Also, it helps you control the lock and other functions via a numeric code.

The digits and symbols are backlit.



Part No. 9155031B

Axis Part No. 01254-001

2N IP Verso – Keypad – black

The numeric keypad module helps you dial users via their phonebook positions or phone numbers. Also, it helps you control the lock and other functions via a numeric code.

The digits and symbols are backlit.

Product Description



Part No. 9155035

Axis Part No. 01258-001

2N IP Verso – 5-button

A module with 5 mechanical speed dial buttons.

The buttons are backlit and can include nametags.



CAUTION

In combination with the **2N IP Verso** intercom, this RFID reader does not meet the conditions of the supplementary regulation to the EU Radio Equipment Directive - effective from 1 August 2025. In combination with the **2N IP Verso 2.0** intercom, it meets the requirements.

Refer to [Impacts of the EU Radio Equipment Directive](#) for more details.

Part No. 9155041

Axis Part No. 01263-001

2N IP Verso – Induction Loop

The induction loop is used for transmitting audio signals directly into hearing aids via a magnetic field.

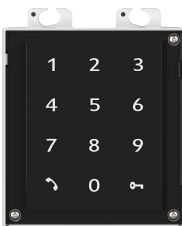

Part No. 9155047

Axis Part No. 01277-001

2N IP Verso – Touch Keypad

The numeric touch keypad module helps you dial users via their phone-book positions or phone numbers, Also, it helps you control the lock and other functions via a numeric code.

The digits and symbols are backlit.

Product Description

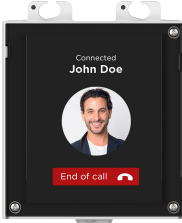

Part No. 9155036

Axis Part No. 01275-001

2N IP Verso – Touch Display

The touch display module allows visitors to dial users in a smartphone-like way.

In addition to a structured phonebook, the display also features a keypad.



CAUTION

In combination with the **2N IP Verso** intercom, this RFID reader does not meet the conditions of the supplementary regulation to the EU Radio Equipment Directive - effective from 1 August 2025. In combination with the **2N IP Verso 2.0** intercom, it meets the requirements.

Refer to [Impacts of the EU Radio Equipment Directive](#) for more details.

Part No. 91550941

2N IP Verso 125 kHz

It provides access control via contactless cards or key fobs.

Supported RFID cards 125 kHz:

- EM4x02
- NXP HiTag2

Product Description



CAUTION

In combination with the **2N IP Verso** intercom, this RFID reader does not meet the conditions of the supplementary regulation to the EU Radio Equipment Directive - effective from 1 August 2025. In combination with the **2N IP Verso 2.0** intercom, it meets the requirements.

Refer to [Impacts of the EU Radio Equipment Directive](#) for more details.

Part No. 91550941US

Axis Part No. 02140-001

2N IP Verso 125 kHz

It provides access control via contactless cards or key fobs.

Supported RFID cards 125 kHz:

- EM4x02
 - NXP HiTag2
-



CAUTION

In combination with the **2N IP Verso** intercom, this RFID reader does not meet the conditions of the supplementary regulation to the EU Radio Equipment Directive - effective from 1 August 2025. In combination with the **2N IP Verso 2.0** intercom, it meets the requirements.

Refer to [Impacts of the EU Radio Equipment Directive](#) for more details.

Part No. 91550942

Axis Part No. 02139-001

2N IP Verso 13.56 MHz, NFC ready

It provides access control via contactless cards or key fobs. The module supports the following 13.56 MHz cards or other carriers:

Supported RFID cards 13.56 MHz:

- **ISO14443A** (MIFARE Classic, MIFARE Plus, MIFARE Mini, MIFARE Ultralight, MIFARE DESFire CSN only)
 - **PicoPass** (HID iClass CSN, Picopass)
 - **FeliCa** (Standard, Lite)
 - **ST SR** (SR, SRI, SRIX)
 - **My2N**
 - **2N PICard**
-



CAUTION

In combination with the **2N IP Verso** intercom, this RFID reader does not meet the conditions of the supplementary regulation to the EU Radio Equipment Directive - effective from 1 August 2025. In combination with the **2N IP Verso 2.0** intercom, it meets the requirements.

Refer to [Impacts of the EU Radio Equipment Directive](#) for more details.

Part No. 91550942-S

Axis Part No. 02141-001

2N IP Verso 13.56 MHz, secured NFC ready

It provides access control via contactless cards or key fobs. The module supports the following 13.56 MHz cards or other carriers:

Supported RFID cards 13.56 MHz:

- **ISO14443A** (MIFARE Classic, MIFARE Plus, MIFARE Mini, MIFARE Ultralight, MIFARE DESFire CSN only)
- **PicoPass** (HID iClass CSN, Picopass)
- **FeliCa** (Standard, Lite)
- **ST SR** (SR, SRI, SRIX)
- **HID PAC** (HID SEOS, HID iClass SE, iClass SR, HID MIFARE DESFire with SIO, HID MIFARE Classic with SIO)
- **My2N**
- **2N PICard**



Part No. 9155045

Axis Part No. 01276-001

2N IP Verso – Biometric Fingerprint Reader

Used for verification of human fingerprints for access control and intercom/third party equipment control.



CAUTION

In combination with the **2N IP Verso** intercom, this RFID reader does not meet the conditions of the supplementary regulation to the EU Radio Equipment Directive - effective from 1 August 2025. In combination with the **2N IP Verso 2.0** intercom, it meets the requirements.

Refer to [Impacts of the EU Radio Equipment Directive](#) for more details.

Part No. 9155086

Axis Part No. 01712-001

2N IP Verso RFID – secured 13.56 MHz, NFC

It provides access control via contactless cards or key fobs. The module supports the following 13.56 MHz cards or other carriers:

Compatible with firmware version 2.13 and higher.

Supported RFID cards 13.56 MHz:

- **ISO14443A** (MIFARE Classic, MIFARE Plus, MIFARE Mini, MIFARE Ultralight, MIFARE DESFire CSN only)
 - **PicoPass** (HID iClass CSN, Picopass)
 - **FeliCa** (Standard, Lite)
 - **ST SR** (SR, SRI, SRIX)
 - **My2N**
 - **2N PICard**
-



CAUTION

In combination with the **2N IP Verso** intercom, this RFID reader does not meet the conditions of the supplementary regulation to the EU Radio Equipment Directive - effective from 1 August 2025. In combination with the **2N IP Verso 2.0** intercom, it meets the requirements.

Refer to [Impacts of the EU Radio Equipment Directive](#) for more details.

Part No. 91550945

Axis Part No. 02778-001

2N IP Verso Bluetooth & RFID – 125 kHz, 13.56 MHz, NFC

A combined Bluetooth & card reader module helps you control access using a numeric code, contactless cards or key fobs. The module supports the 125 kHz and 13.56 MHz cards and/or other carriers.

Supported RFID cards 125 kHz:

- EM4x02
- NXP HiTag2

Supported RFID cards 13.56 MHz:

- **ISO14443A** (MIFARE Classic, MIFARE Plus, MIFARE Mini, MIFARE Ultralight, MIFARE DESFire CSN only)
 - **PicoPass** (HID iClass CSN, Picopass)
 - **FeliCa** (Standard, Lite)
 - **ST SR** (SR, SRI, SRIX)
 - **My2N**
 - **2N PICard**
-



CAUTION

In combination with the **2N IP Verso** intercom, this RFID reader does not meet the conditions of the supplementary regulation to the EU Radio Equipment Directive - effective from 1 August 2025. In combination with the **2N IP Verso 2.0** intercom, it meets the requirements.

Refer to [Impacts of the EU Radio Equipment Directive](#) for more details.

Part No. 91550945-S

Axis Part No. 02444-001

2N IP Verso Bluetooth & RFID – 125 kHz, secured 13.56 MHz, NFC

A combined Bluetooth – card reader module helps you control access using an access code, **My2N** in your smartphone or an access card. The module supports the 125 kHz and 13.56 MHz cards and/or other carriers.

Supported RFID cards 125 kHz:

- EM4x02
- NXP HiTag2

Supported RFID cards 13.56 MHz:

- **ISO14443A** (MIFARE Classic, MIFARE Plus, MIFARE Mini, MIFARE Ultralight, MIFARE DESFire CSN only)
 - **PicoPass** (HID iClass CSN, Picopass)
 - **FeliCa** (Standard, Lite)
 - **ST SR** (SR, SRI, SRIX)
 - **HID PAC** (HID SEOS, HID iClass SE, iClass SR, HID MIFARE DESFire with SIO, HID MIFARE Classic with SIO)
 - **My2N**
 - **2N PICard**
-



CAUTION

In combination with the **2N IP Verso** intercom, this RFID reader does not meet the conditions of the supplementary regulation to the EU Radio Equipment Directive - effective from 1 August 2025. In combination with the **2N IP Verso 2.0** intercom, it meets the requirements.

Refer to [Impacts of the EU Radio Equipment Directive](#) for more details.

Part No. 91550946

Axis Part No. 02779-001

2N IP Verso Touch keypad & RFID – 125 kHz, 13.56 MHz, NFC

A combined touch keypad – card reader module helps you control access using a numeric code, contactless cards or key fobs. The module supports the 125 kHz and 13.56 MHz cards and/or other carriers.

Supported RFID cards 125 kHz:

- EM4x02
- NXP HiTag2

Supported RFID cards 13.56 MHz:

- **ISO14443A** (MIFARE Classic, MIFARE Plus, MIFARE Mini, MIFARE Ultralight, MIFARE DESFire CSN only)
 - **PicoPass** (HID iClass CSN, Picopass)
 - **FeliCa** (Standard, Lite)
 - **ST SR** (SR, SRI, SRIX)
 - **My2N**
 - **2N PICard**
-



CAUTION

In combination with the **2N IP Verso** intercom, this RFID reader does not meet the conditions of the supplementary regulation to the EU Radio Equipment Directive - effective from 1 August 2025. In combination with the **2N IP Verso 2.0** intercom, it meets the requirements.

Refer to [Impacts of the EU Radio Equipment Directive](#) for more details.

Part No. 91550946-S

Axis Part No. 02443-001

2N IP Verso Touch keypad & RFID – 125 kHz, secured 13.56 MHz, NFC

A combined touch keypad – card reader module helps you control access using a numeric code, contactless cards or key fobs. The module supports the 125 kHz and 13.56 MHz cards and/or other carriers.

Supported RFID cards 125 kHz:

- EM4x02
- NXP HiTag2
- HID Prox

Supported RFID cards 13.56 MHz:

- **ISO14443A** (MIFARE Classic, MIFARE Plus, MIFARE Mini, MIFARE Ultralight, MIFARE DESFire CSN only)
 - **PicoPass** (HID iClass CSN, Picopass)
 - **FeliCa** (Standard, Lite)
 - **ST SR** (SR, SRI, SRIX)
 - **HID PAC** (HID SEOS, HID iClass SE, iClass SR, HID MIFARE DESFire with SIO, HID MIFARE Classic with SIO)
 - **My2N**
 - **2N PICard**
-



CAUTION

In combination with the **2N IP Verso** intercom, this RFID reader does not meet the conditions of the supplementary regulation to the EU Radio Equipment Directive - effective from 1 August 2025. In combination with the **2N IP Verso 2.0** intercom, it meets the requirements.

Refer to [Impacts of the EU Radio Equipment Directive](#) for more details.

Part No. 91550947

Axis Part No. 02781-001

2N IP Verso Touch keypad & Bluetooth & RFID – 125 kHz, 13.56 MHz, NFC

A combined touch keypad – Bluetooth – card reader module helps you control access using an access code, **My2N** in your smartphone or an access card. The module supports the 125 kHz and 13.56 MHz cards and/or other carriers.

Supported RFID cards 125 kHz:

- EM4x02
- NXP HiTag2

Supported RFID cards 13.56 MHz:

- **ISO14443A** (MIFARE Classic, MIFARE Plus, MIFARE Mini, MIFARE Ultralight, MIFARE DESFire CSN only)
 - **PicoPass** (HID iClass CSN, Picopass)
 - **FeliCa** (Standard, Lite)
 - **ST SR** (SR, SRI, SRIX)
 - **My2N**
 - **2N PICard**
-



CAUTION

In combination with the **2N IP Verso** intercom, this RFID reader does not meet the conditions of the supplementary regulation to the EU Radio Equipment Directive - effective from 1 August 2025. In combination with the **2N IP Verso 2.0** intercom, it meets the requirements.

Refer to [Impacts of the EU Radio Equipment Directive](#) for more details.

Part No. 91550947-S

Axis Part No. 02782-001

2N IP Verso Touch keypad & Bluetooth & RFID - 125 kHz, secured 13.56 MHz, NFC

A combined touch keypad – Bluetooth – card reader module helps you control access using an access code, **My2N** in your smartphone or an access card. The module supports the 125 kHz and 13.56 MHz cards and/or other carriers.

Supported RFID cards 125 kHz:

- EM4x02
- NXP HiTag2
- HID Prox

Supported RFID cards 13.56 MHz:

- **ISO14443A** (MIFARE Classic, MIFARE Plus, MIFARE Mini, MIFARE Ultralight, MIFARE DESFire CSN only)
- **PicoPass** (HID iClass CSN, Picopass)
- **FeliCa** (Standard, Lite)
- **ST SR** (SR, SRI, SRIX)
- **HID PAC** (HID SEOS, HID iClass SE, iClass SR, HID MIFARE DESFire with SIO, HID MIFARE Classic with SIO)
- **My2N**
- **2N PICard**

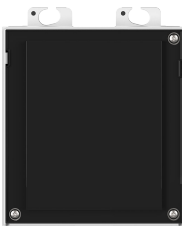

Part No. 9155039

Axis Part No. 01261-001

2N IP Verso – Blind Panel

The blind panel module helps fill up redundant space in installations.

The main unit is supplied with one blind panel module.

Product Description



Part No. 9155034

Axis Part No. 01257-001

I/O Module

The module provides logical inputs and outputs for integration of sensors or other devices.

The module is installed under another module, i.e. needs no separate position.



Part No. 9155037

Axis Part No. 01259-001

Wiegand Module

The Wiegand module helps you interconnect your system with other systems via the Wiegand interface.

The module is installed under another module, i.e. needs no separate position.



Part No. 91550371

Axis Part No. 02577-001

OSDP Module

The OSDP module provides OSDP communication with a connected OSDP device (control panel, door controller) and **2N IP Verso** (placed outside).

The module is installed under another module, i.e. needs no separate position.

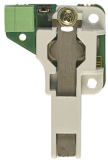

Part No. 9155038

Axis Part No. 01260-001

Tamper Switch

Tamper Switch is a module which detects that the device has been opened or the top cover removed.

The module is installed under another module, i.e. needs no separate position.

Remember to purchase the I/O module (9155034, 01257-001), along with the Tamper Switch.

Product Description

Part No. 9159010



Axis Part No. 01386-001

Security Relay

A handy add-on that significantly enhances security. It prevents lock tampering.

To be installed between the protected device from which it is also powered and the lock controlled by it.

Part No. 9155198SET



Axis Part No. 01975-001

Security Package for 2N Devices

The security package provides increased door security.

The safety package includes a safety relay, a protection switch and an I/O module.

Power Supply

Part No. 91378100E (with EU cable)



Part No. 91378100US (with US cable)

Axis Part No. 01403-001

One-port PoE injector

For intercom supply via Ethernet cable where the PoE switch is absent.

Part No. 9159052



Axis Part No. 01393-001

12 V / 1 A power supply for 2N Induction Loop

The external induction loop power supply has 230 V AC input voltage and 12 V DC output voltage.

Licenses



Part No. 9137909

Axis Part No. 01380-001

Gold License

Includes the Enhanced Video, Enhanced Integration and Lift Control licenses.



Part No. 9137910

Axis Part No. 01381-001

InformaCast License



Part No. 9137921

Axis Part No. 03160-001

MS Teams license



TIP

- Refer to the Configuration Manual for 2N IP Intercoms, Subs. [Function Licensing](#) for details.
- Please refer to the local 2N distributor for more accessories and recommendations.

Other accessories



Part No. 9159013

Axis Part No. 02523-001

Departure button

The departure button is connected to the device logic input for opening the door from inside the building.



Part No. 9159012

Axis Part No. 01388-001

Magnetic door contact

Set for installation on a door, enabling the status of door opening to be ascertained. Used where the device is used for door protection, open door detection or forced opening.



Part No. 9134173

Axis Part No. 01384-001

MIFARE RFID chip card, 13.56 Hz

RFID chip card, MIFARE Classic 1k, 13.56 MHz.



Part No. 9134174

Axis Part No. 01385-001

MIFARE RFID chip fob, 13.56 MHz

RFID chip fob, MIFARE Classic 1k, 13.56 MHz.



Part No. 9134165E

Axis Part No. 01395-001

EM RFID chip card, 125 Hz

RFID chip card, type EM4100, 125 kHz.



Part No. 9134166E

Axis Part No. 01396-001

EM RFID chip fob, 125 kHz

RFID chip fob, type EM4100, 125 kHz.

Product Description

Part No. 11202601

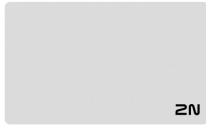

Axis Part No. 02787-001

MIFARE DESFire RFID chip card, 13.56 MHz

RFID chip fob, type MIFARE DESFire EV3 4 K, 13.56 MHz (ISO/IEC14443A).

Suitable for data encryption in **PICard Commander**.

The package includes 10 pieces.

Part No. 11202602



Axis Part No. 02788-001

MIFARE DESFire RFID fob, 13.56 MHz

RFID fob, type MIFARE DESFire EV3 4 K, 13.56 MHz (ISO/IEC14443A).

Suitable for data encryption in **PICard Commander**.

The package includes 10 pieces.

Part No. 9137420E



Axis Part No. 01399-001

External RFID reader, 125 kHz

External RFID card reader connectable to a PC via a USB interface.

Suitable for system administration and adding of EM41xx cards (125 kHz) using the device web configuration or **PICard Commander**.

Product Description



Part No. 9137421E

Axis Part No. 01399-001

External RFID reader, 13.56 MHz + 125 kHz, NFC/HCE

External RFID card reader connectable to a PC via a USB interface.

Suitable for system administration and adding of 13.56 MHz/125 kHz cards and Android devices with NFC/HCE support using the device web configuration or the **Access Commander**.

Suitable for uploading of MIFARE DESFire cards into the **PICard Commander** encryption application.

The following RFID cards can be read:

Supported RFID cards 125 kHz:

- EM4x02
- NXP HiTag2

Supported RFID cards 13.56 MHz:

- **ISO14443A** (MIFARE Classic, MIFARE Plus, MIFARE Mini, MIFARE Ultralight, MIFARE DESFire CSN only)
- **PicoPass** (HID iClass CSN, Picopass)
- **FeliCa** (Standard, Lite)
- **ST SR** (SR, SRI, SRIX)
- **My2N**
- **2N PICard**

The device can also read the 13.56 MHz 2N PICard RFID cards.



Part No. 9137424E

Axis Part No. 01527-001

External secured RFID reader, 13.56 MHz + 125 kHz, NFC/HCE

External secured RFID card reader connectable to a PC via a USB interface.

Suitable for system administration and adding of 13.56 MHz/125 kHz cards and Android devices with NFC/HCE support using the device web configuration or the **Access Commander**.

Suitable for uploading of MIFARE DESFire cards into the **PICard Commander** encryption application.

The following RFID cards can be read:

Supported RFID cards 125 kHz:

- EM4x02
- NXP HiTag2
- HID Prox

Supported RFID cards 13.56 MHz:

- **ISO14443A** (MIFARE Classic, MIFARE Plus, MIFARE Mini, MIFARE Ultralight, MIFARE DESFire CSN only)
- **PicoPass** (HID iClass CSN, Picopass)
- **FeliCa** (Standard, Lite)
- **ST SR** (SR, SRI, SRIX)
- **HID PAC** (HID SEOS, HID iClass SE, iClass SR, HID MIFARE DESFire with SIO, HID MIFARE Classic with SIO)
- **My2N**
- **2N PICard**



Part No. 9137423E

Axis Part No. 01401-001

External fingerprint reader (USB interface)

External fingerprint reader connectable to a PC via a USB interface.



Part No. 9137410E

Axis Part No. 01397-001

External IP relay, 1 output

Stand-alone IP relay, which can be controlled from an intercom via HTTP commands and helps control devices from an unlimited distance.



Part No. 9137411E

Axis Part No. 01398-001

External IP relay, 4 outputs, PoE

Stand-alone IP relay, which can be controlled from an intercom via HTTP commands and helps control devices from an unlimited distance.



Part No. 9159014EU/US/UK

Axis Part No. 01404-001

2N 2Wire (set of 2 adaptors and power source for EU/US/UK)

The 2N 2Wire converter allows you to use the existing 2-wire cabling from your original doorbell or door intercom for connecting any IP device. You do not have to configure anything, all you need is one 2N 2Wire unit at each end of the cable and a power supply connected to at least one of these units. The 2N 2Wire unit then provides PoE power not only to the second converter, but to all of the connected IP end devices.



Part No. 1120103/1120103EU

Axis Part No. 02318-001

NVT PoLRE LPC Switch

The switch provides an IP solution with analog cabling.

The package includes 2 SIP adapters. Additional adapters can be ordered (1120104, 02319-001).



Part No. 1120104

Axis Part No. 02319-001

NVT PhyLink Adapter

SIP adapter for switch use (1120103, 02318-001).

The package includes 6 pieces.

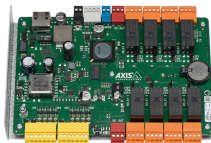

Part No. 9160501

Axis Part No. 0820-001

AXIS A9188 Network I/O Relay Module

The relay is part of the lift access solution. One relay can control up to 8 floors. Intercom or access unit can be interconnected with up to 8 AXIS A9188 lift relays. The solution is thus suitable for up to 64 floors.

Product Description



Part No. 9137422E

Axis Part No. 01402-001

2N IP Intercom – External Bluetooth reader (USB interface)

An external Bluetooth reader is connected to your computer via USB. It can be used for pairing the new users who want to use their smart-phones with the **2N My2N** application for access to controlled areas.

A USB driver is required for the external reader to work properly.



Part No. 9155051

Axis Part No. 01270-001

2N IP VersoOne-button blind

The one-button blind helps blind a button on the main unit.



Part No. 9155051B

Axis Part No. 01523-001

2N IP VersoOne-button blind, black version

The one-button blind helps blind a button on the main unit.

Package Completeness Check

Please check the product delivery before installation. Contents:

1x **2N IP Verso**

1x Certificate of ownership

1x Brief Manual

1x Hex key

3x 3 x 8 mm stainless steel thread-forming lens head screw for plastic

1x stainless steel cylinder head screw into plastic

Product Description

2x Frame fitting

2x tactile sticker

Module / Frame Package Completeness Check

The package of modules for **2N IP Verso** includes:

3x 3 x 8 mm stainless steel thread-forming lens head screw for plastic

The package of frames for **2N IP Verso** includes:

Part Nos. 9155011, 9155011B, 9155012, 9155012B, 9155013, 9155013B

Axis Part Numbers 01278-001, 01279-001, 01280-001, 01281-001, 01282-001, 01283-001

3x 4 x 20 mm stainless steel thread-forming lens head screw for plastic

Part Nos. 9155021, 9155021B, 9155022, 9155022B, 9155023, 9155023B

Axis Part Numbers 01287-001, 01288-001, 01289-001, 01290-001, 01291-001, 01292-001

2x 4 x 50 mm stainless steel flat head screw

2x 8 x 40 mm dowel



CAUTION

If spare accessories other than the specified types are used, the device warranty might become null and void.

Installation

For optimum functionality, it is recommended that the device is placed at a height according to the following scheme:

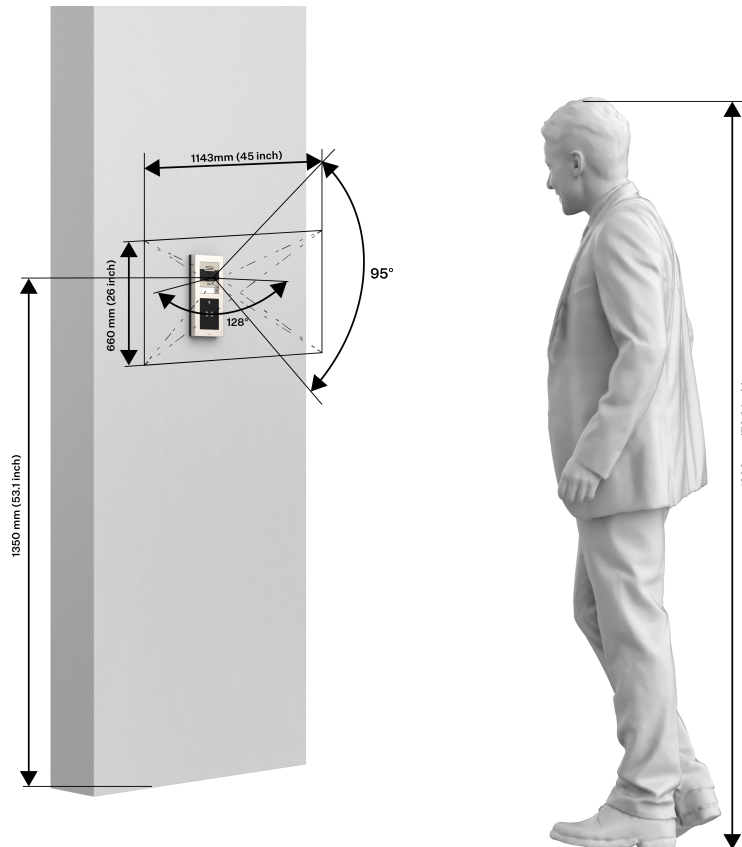

Mechanical Installation

Installation Conditions

Make sure that the following 2N IP Verso installation conditions are met.

- There must be enough space for the device installation.
- Make sure that the dowel holes have the required diameter. If the diameters are too large, the dowels may get loose! Use the mounting glue to secure the dowels if necessary.
- Do not use low-quality dowels to avoid their falling out of the wall!
- Make sure that the depths of the dowel holes are accurate!
- Before starting the mechanical installation on a selected place, make sure carefully that the preparations associated with it (drilling, wall cutting) cannot damage the electrical, gas, water and other existing wires and pipes.
- The device is designed for vertical wall mounting (perpendicular to the floor) in the height of up to 1350 mm above the floor. If necessary, operate the device in a position other than as aforementioned for a short time only, for quick testing purposes in a servicing center, for example.
- Make sure that the plasterboard interior does not show a pressure value significantly different from that of the room, e.g. that it is not connected with overpressure ventilation. If the difference is too great, separate the device in terms of pressure (using, e.g., a mounting box) and seal the cable passage.

Installation

- The device is not designed for environments with increased vibrations such as means of transport, machine rooms and so on.
- The device may not be exposed to aggressive gas, acid vapors, solvents, etc.
- The device is not intended for direct connection into the Internet/WAN. The device must be connected to the Internet/WAN via a separating active network element (switch/router).
- Having removed the front panel, make sure that no dirt gets inside the product, especially onto the sealing surface.
- Avoid strong electromagnetic radiation on the installation site.



WARNING



- Make sure that the main unit is not removed from its base, that is why never remove the marked screw covered in resin in the right-hand upper corner. Any screw tampering results in the warranty becoming null and void.
- The grounding element in the left-hand upper corner of the unit must remain undamaged and stuck all the time.



- It is forbidden to use silicone or any other sealing material on the marked and hatched places.



CAUTION

- When the proper installation instructions are not met, water might get in and destroy the electronics. As the device circuits are constantly under voltage water leakage causes electrochemical reaction. The manufacturer's warranty shall be void for products damaged in this way!
- Exceeding the allowed operating temperature may not affect the device immediately but leads to premature ageing and lower reliability. For the acceptable range of operating temperatures and relative humidity values refer to [S. Technical Parameters \(p. 160\)](#).
- Any intentional mechanical damage to the device (drilling, main unit tampering, etc.) results in a loss of warranty.
- The device installation and setting should only be performed by professionally qualified persons.
- When mounting on glass, it is necessary to first ensure the smoothness and cleanliness of the surface. A greasy and dirty surface can cause insufficient adhesion and subsequent peeling of double-sided adhesive tape.

Installation Tips

- The recommended height is 135 cm for standard installations (100–120 cm for disabled persons) from the floor to the device camera level. The installation heights may vary depending on the device use.

Viewing angle

128° (H), 95° (V)

Flush mounting

While flush mounting, make sure that the box is installed properly, i.e. with the box edge on the wall surface. There are stops on the box sides to secure a proper position. Remember to break them off after walling in. Make sure that the frame is placed precisely on the box without touching the wall to make the sealing fully functional. It is recommended that some universal/sanitary silicone, which is inert to the surface and UV and water resistant, is used to prevent water from penetrating into the device. Refer to the detailed pictorial instructions inside the package.



WARNING



It is forbidden to use silicone or any other sealing material on the marked and hatched places (on the device bottom in particular).

Flush mounting – into classic bricks, hollow bricks, thermally insulated fronts, etc.

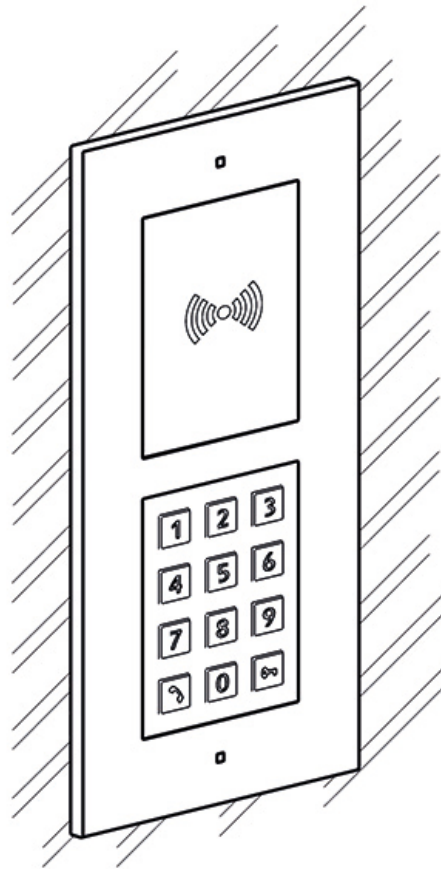

What you need for mounting:

- **2N IP Verso**
- a properly cut hole as instructed in the box package
- plaster, mounting glue, mounting foam or mortar as necessary
- flush mounting box and frame
 - for 1-modules: box (9155014, 01284-001) frame (9155011/9155011B, 01278-001/01279-001)
 - for 2-modules: box (9155015, 01285-001), frame (9155012/9155012B, 01280-001/01281-001)
 - for 3-modules: box (9155016, 01286-001), frame(9155013/9155013B, 01282-001/01283-001)



NOTE

The one-module frame is designed for stand-alone installations of extending modules such as OUT readers, etc. A 2-module frame is required for the main unit installation.

To install a device **2N IP Verso** into a wall, mount the flush mounting box first. Then install the device into it.

2-Module Installation

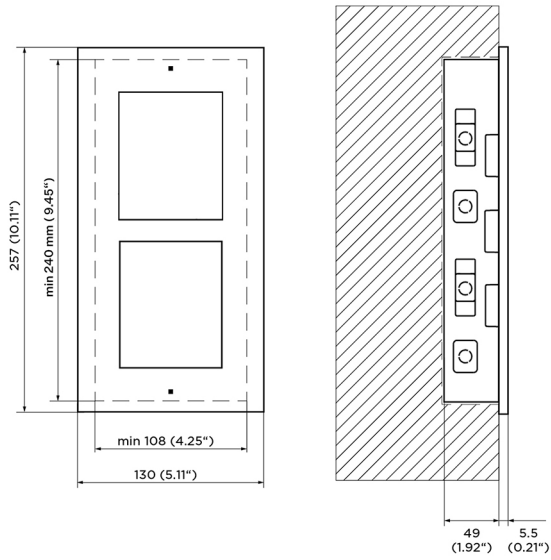

Box Installation

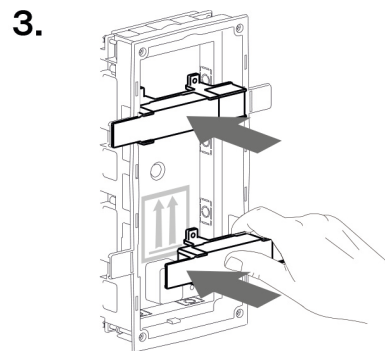
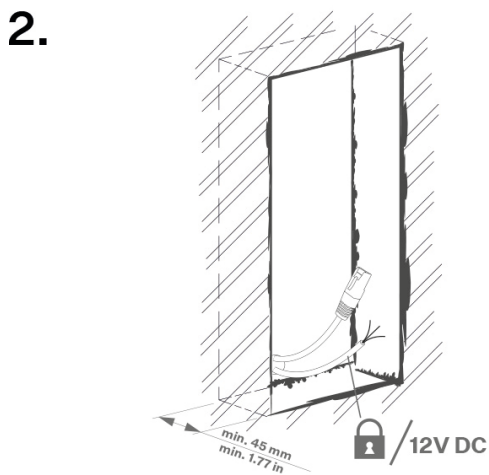
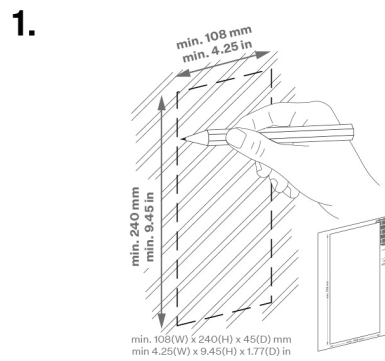
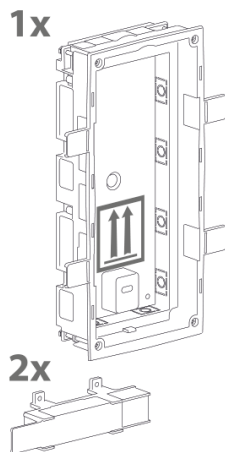

4.

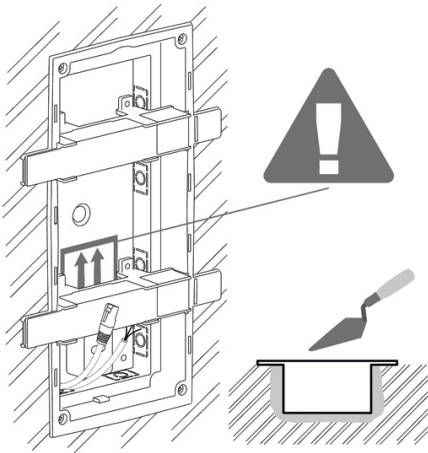

5.

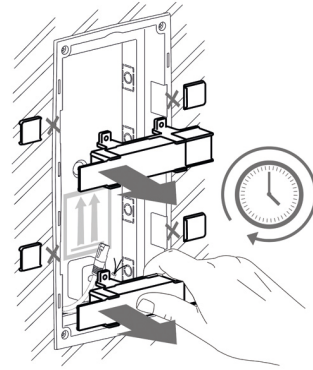

6.

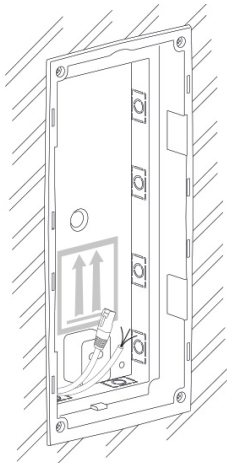

WARNING

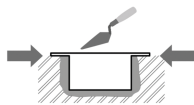

Make sure that the flush mounting box edges are not aligned with the wall but overlap the wall surface. When the proper box installation instructions are not met, water might get in and destroy the device installed. Side stops are used for a correct wall position.



CAUTION

When the walling material has hardened, break off the side stops.

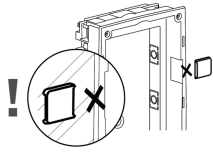

2-Module Installation into Box

1.

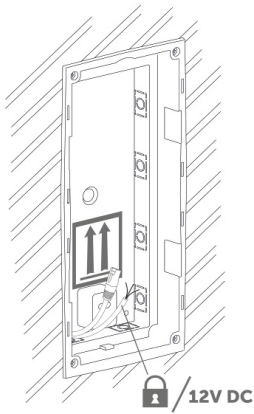

2.

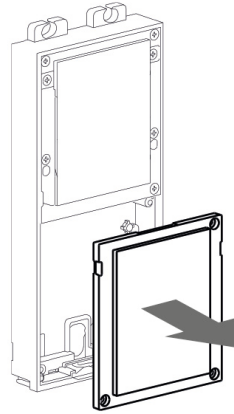

3.

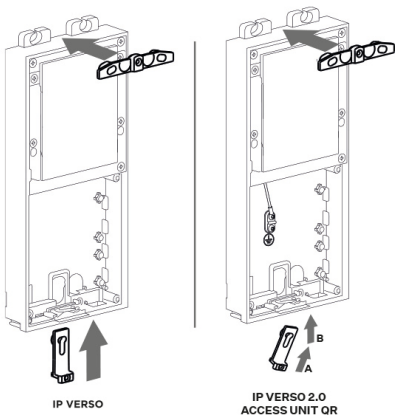

4.

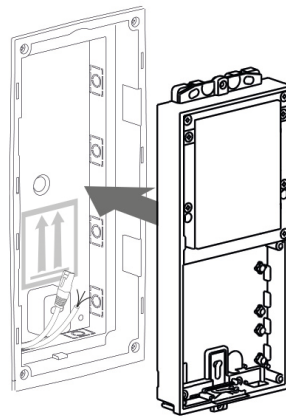

Installation

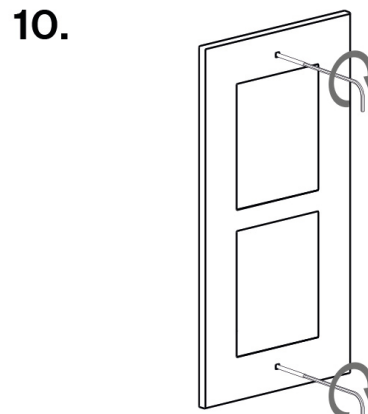
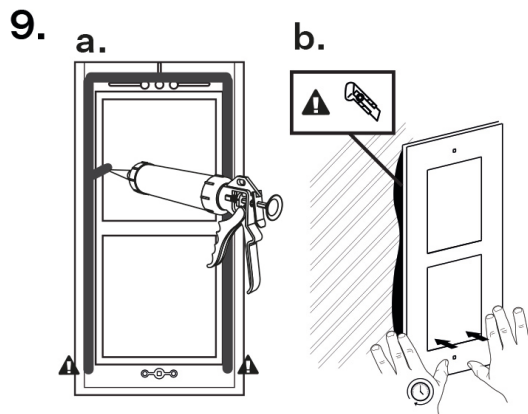
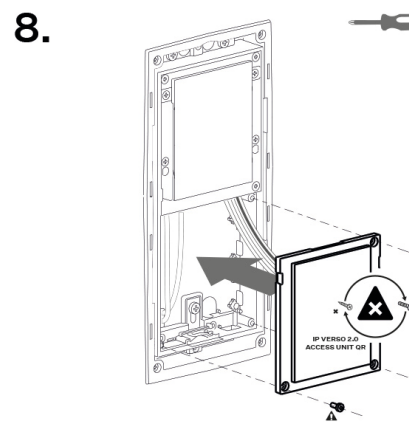
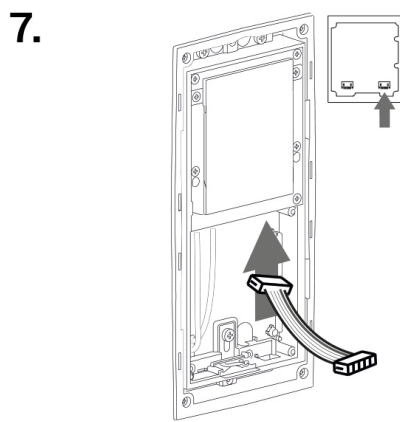
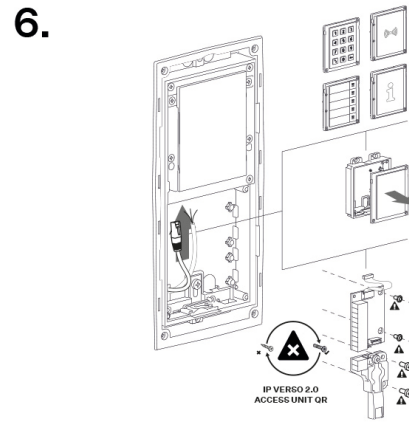
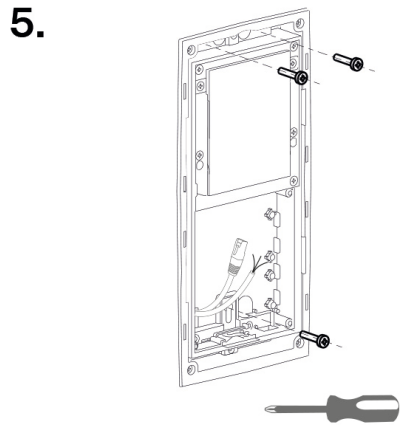

Installing of Multiple 2-module Boxes Next to Each Other

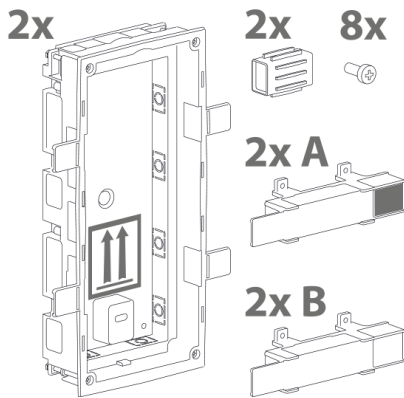
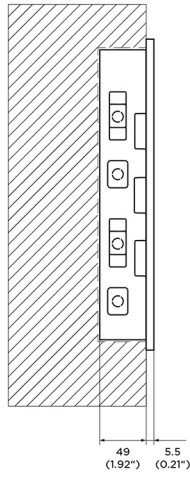
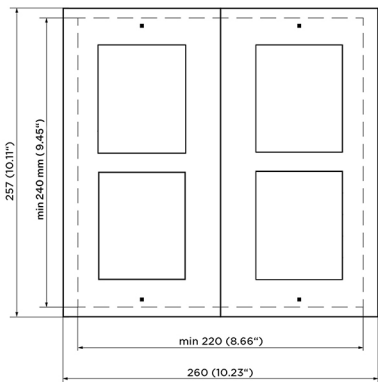

1.

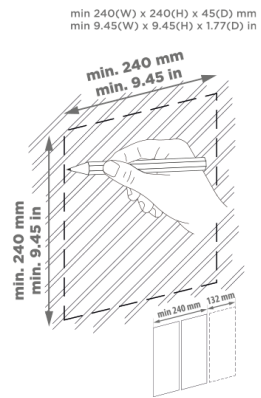

2.

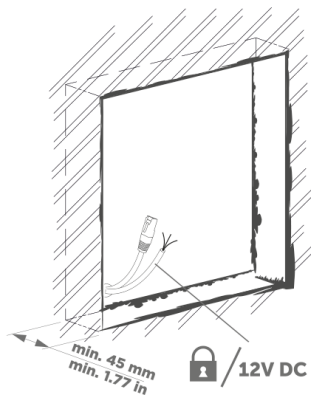

3.

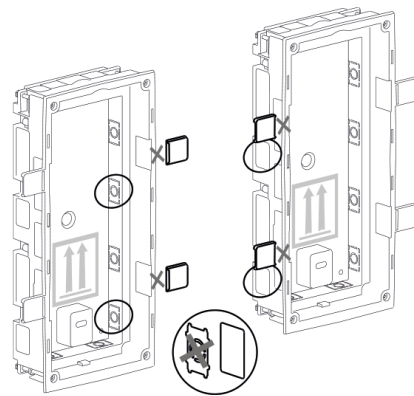

Installation

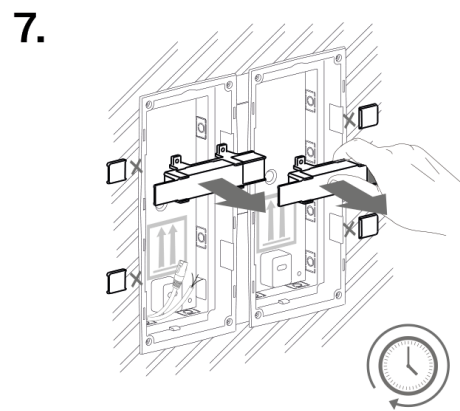
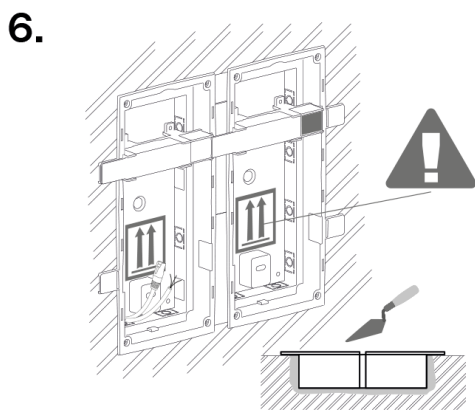
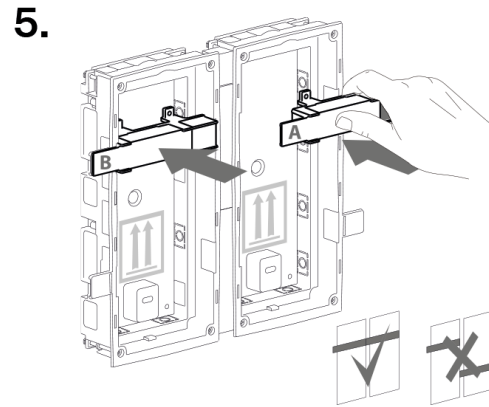
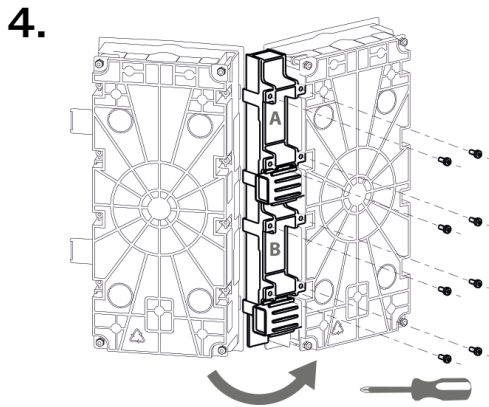

WARNING

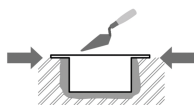

Make sure that the flush mounting box edges are not aligned with the wall but overlap the wall surface. When the proper box installation instructions are not met, water might get in and destroy the device installed. Side stops are used for a correct wall position.



CAUTION

When the walling material has hardened, break off the side stops.

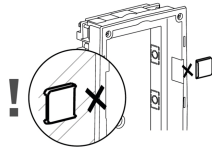

Installation of Multiple 2-Modules into Box

1.

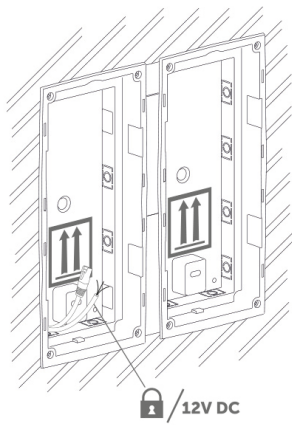

2.

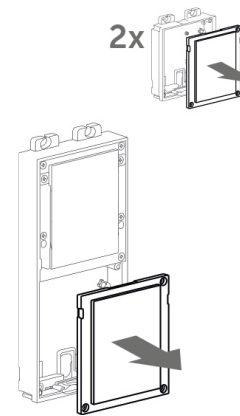

3.

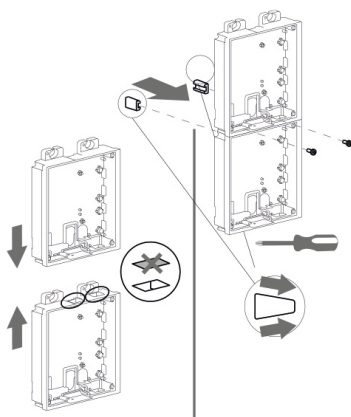

4.

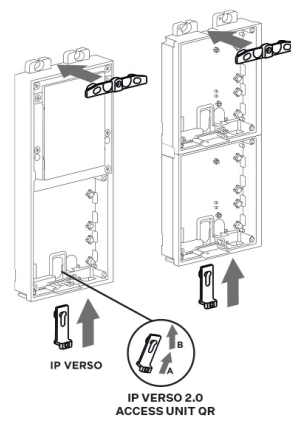

Installation

5.



6.

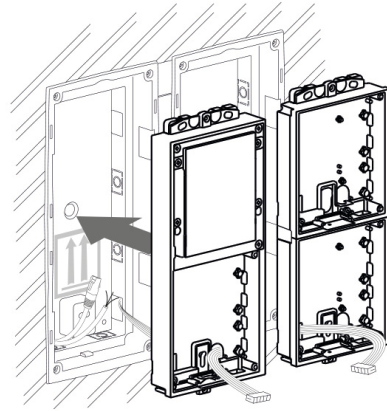

7.

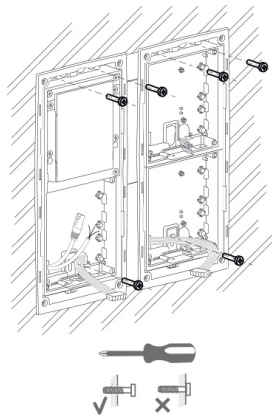

8.

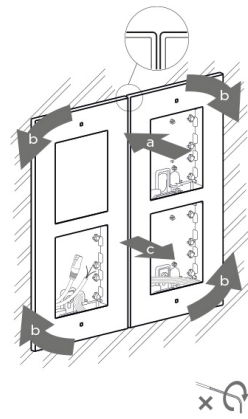

9.

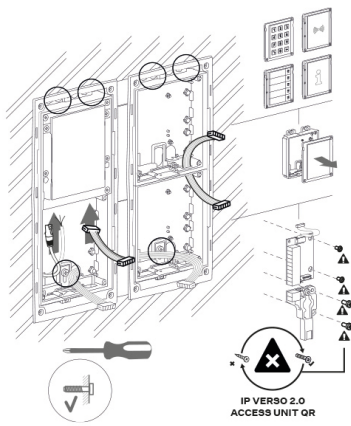

10.

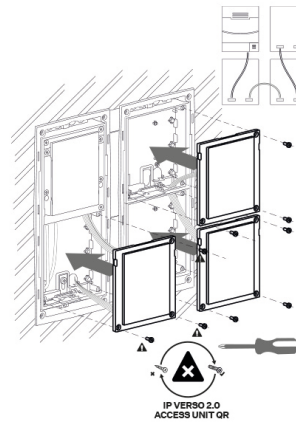

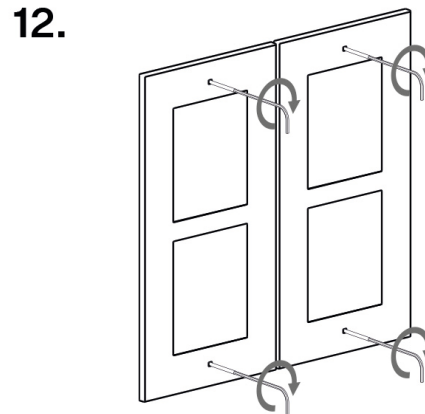
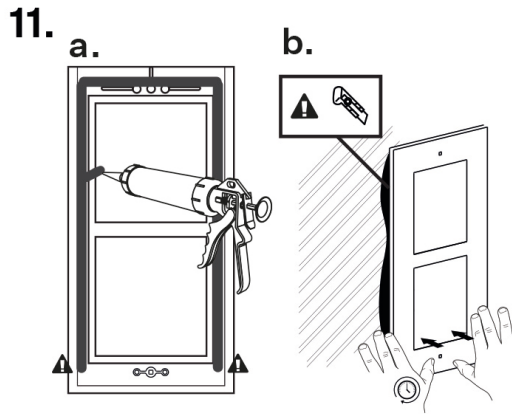

Frame Attachment

Check the frame sealing before fitting the frame.

Screw the flush mounting frame in the upper and bottom parts.

Hang the surface mounting frame on the hook in the upper part and then screw it tight in the bottom part.

3-Module Installation

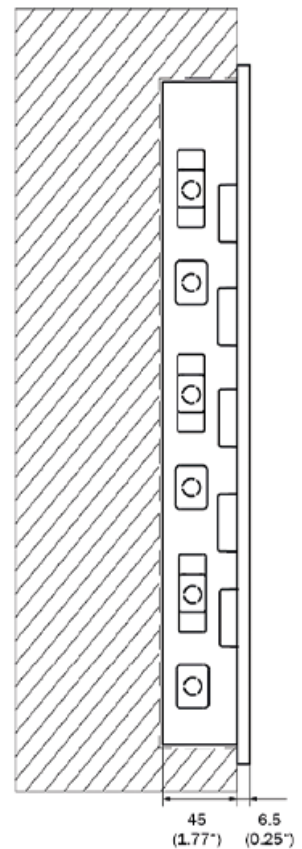
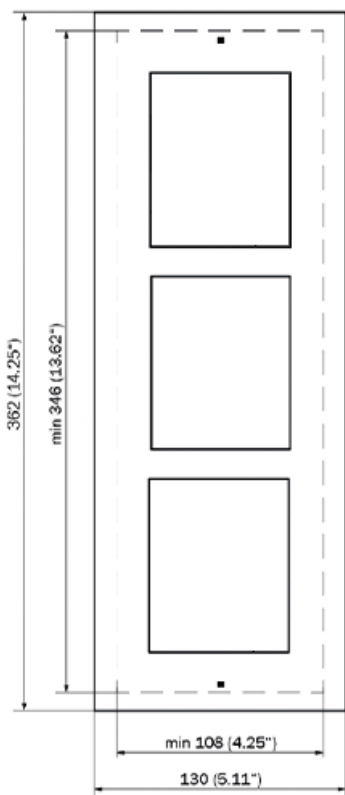

Box Installation

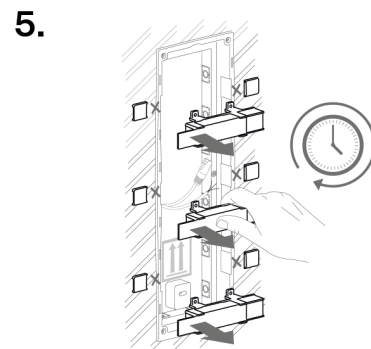
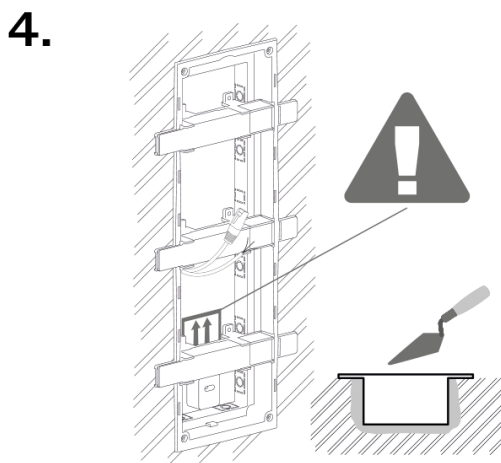
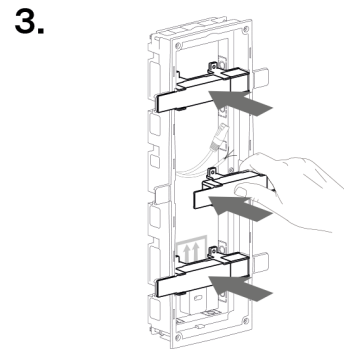
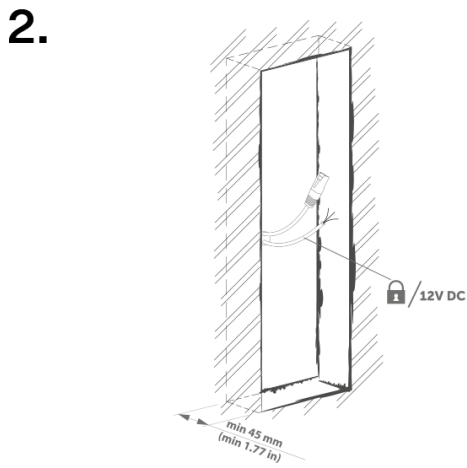
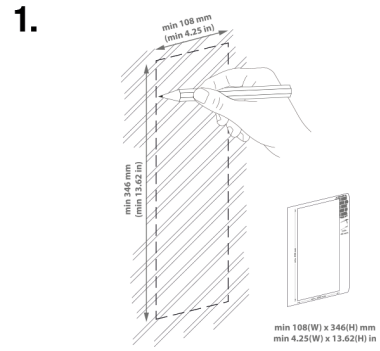

6.

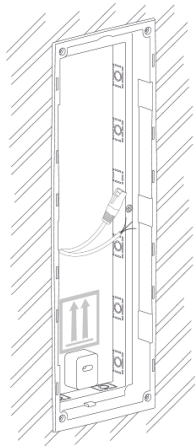

WARNING

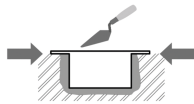

Make sure that the flush mounting box edges are not aligned with the wall but overlap the wall surface. When the proper box installation instructions are not met, water might get in and destroy the device installed. Side stops are used for a correct wall position.



CAUTION

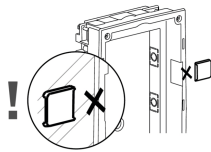

When the walling material has hardened, break off the side stops.

Installation of Multiple 3-Module Boxes Next to Each Other

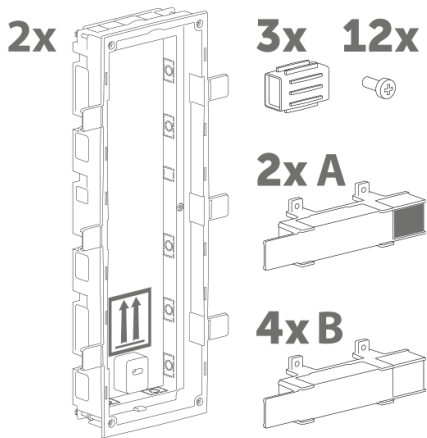
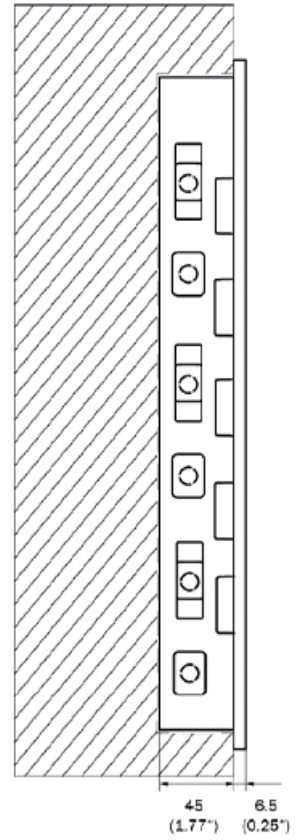
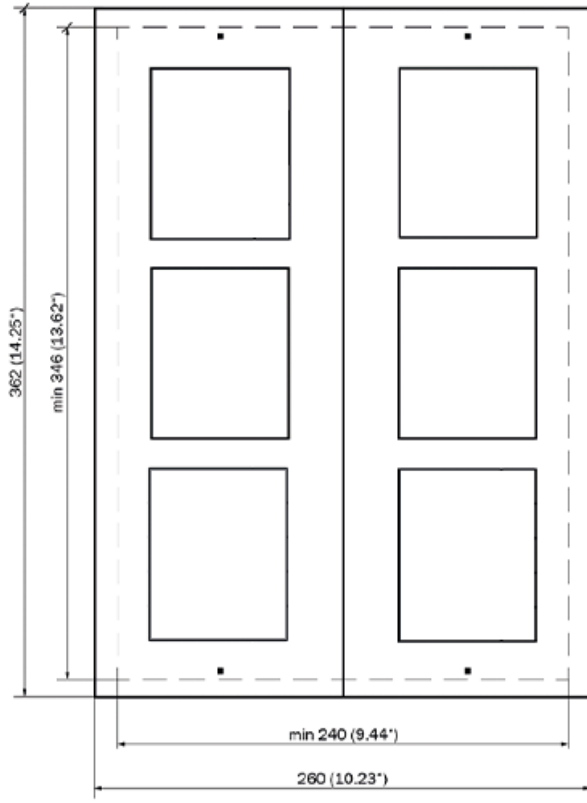

1.

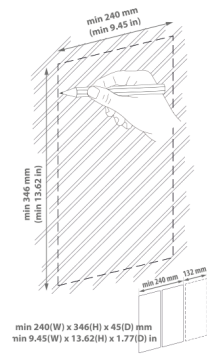

Installation

2.

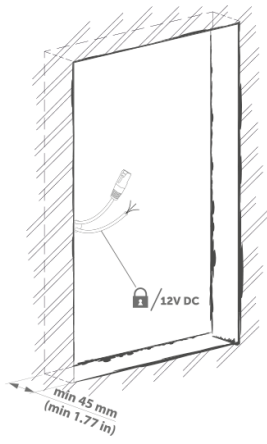

3.

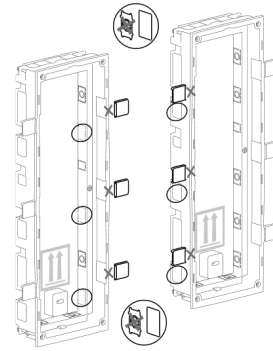

4.

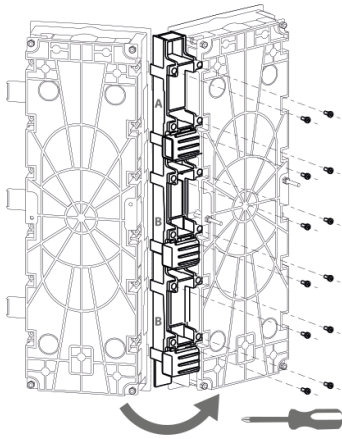

5.

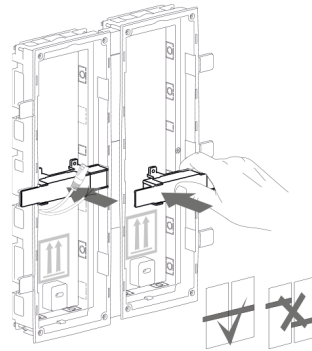

6.

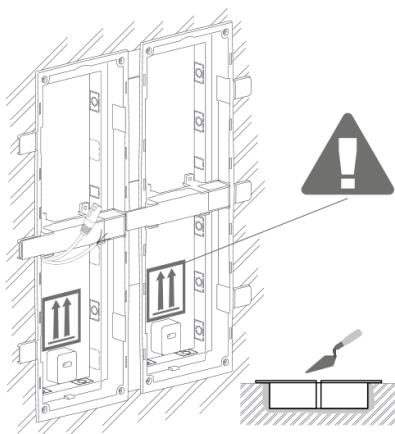

7.

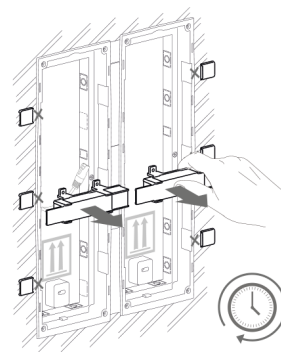

8.

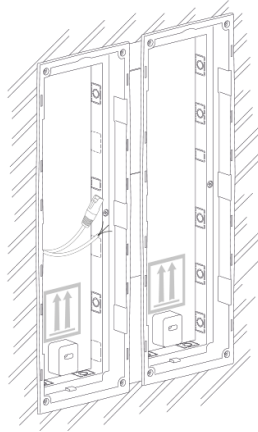

WARNING

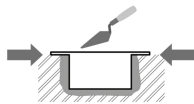

Make sure that the flush mounting box edges are not aligned with the wall but overlap the wall surface. When the proper box installation instructions are not met, water might get in and destroy the device installed. Side stops are used for a correct wall position.



CAUTION

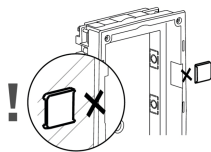

When the walling material has hardened, break off the side stops.

3-Module Installation into Box

1.

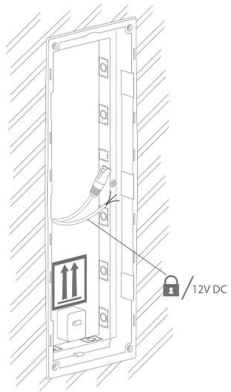

2.

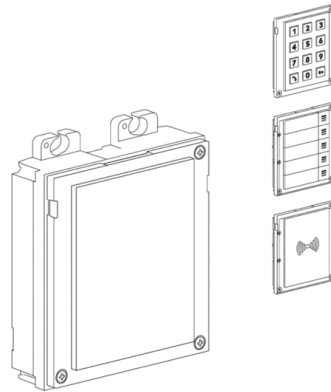

3.

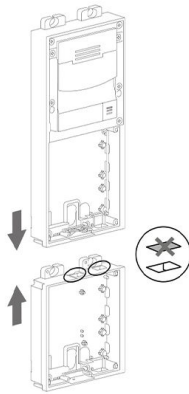

4.

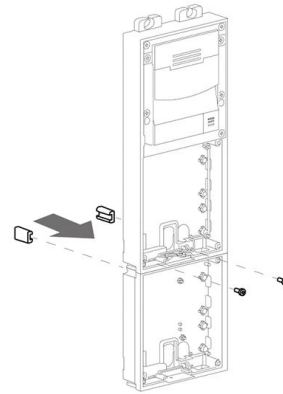

5.

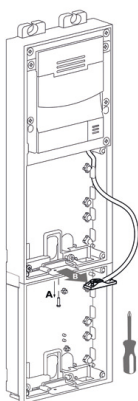

6.

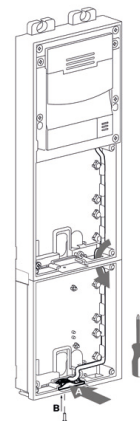

Installation

7.

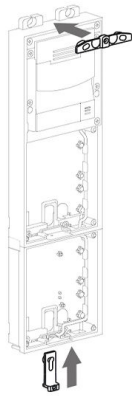

8.

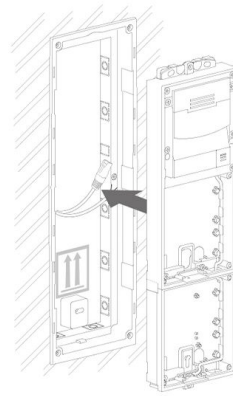

9.

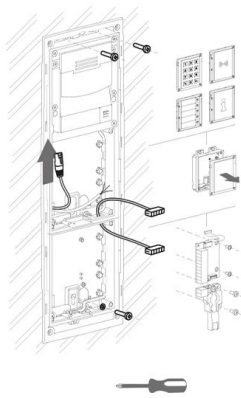

10.

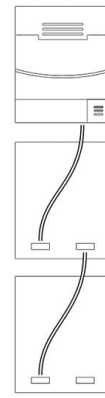

11.

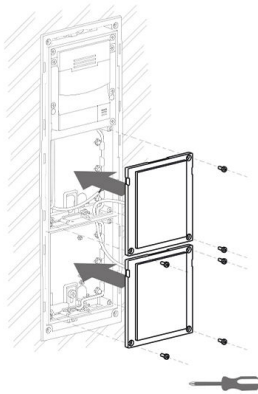

12.



Frame Attachment

Check the frame sealing before fitting the frame.

Screw the flush mounting frame in the upper and bottom parts.

Hang the surface mounting frame on the hook in the upper part and then screw it tight in the bottom part.

1-Module Installation

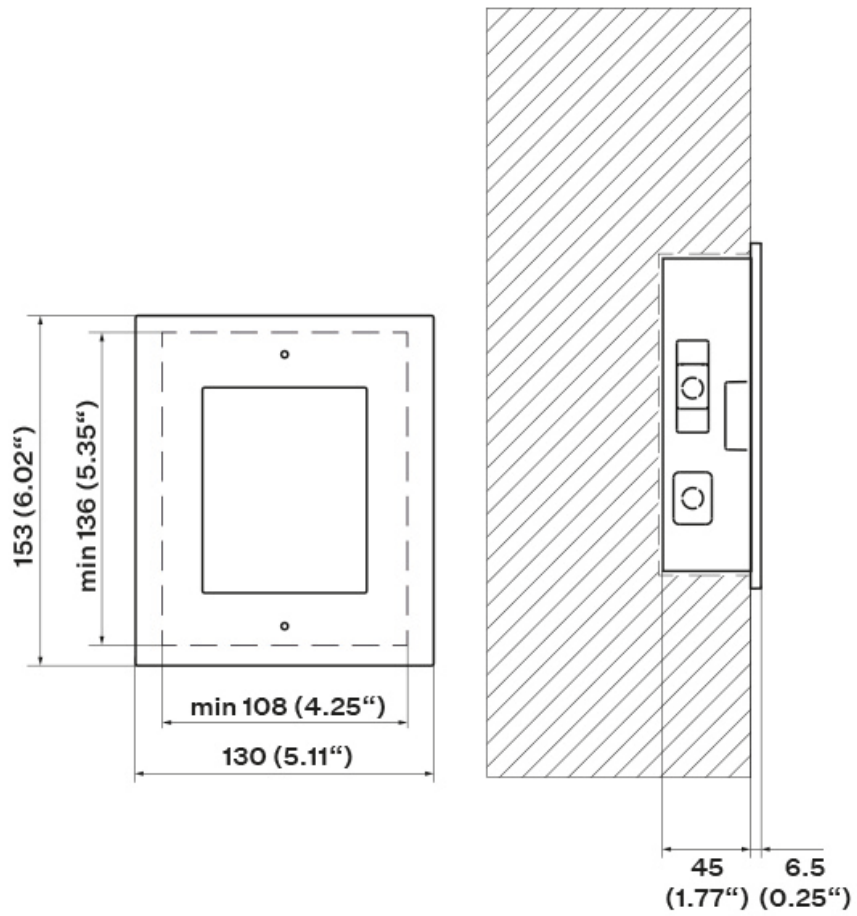

Box Installation

1x

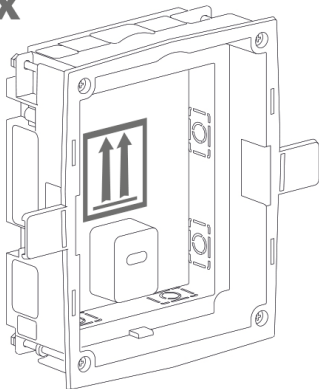

1.

min 108(W) x 136(H) x 45(D) mm
min 4.25(W) x 5.35(H) x 1.77(D) in

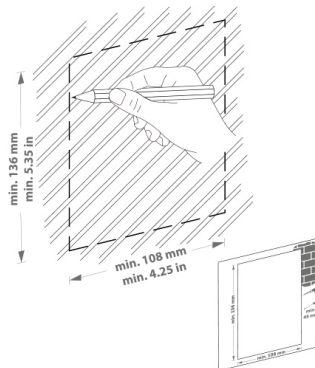

2.

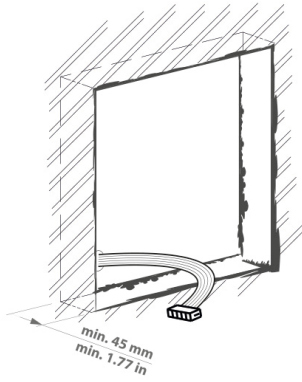

3.

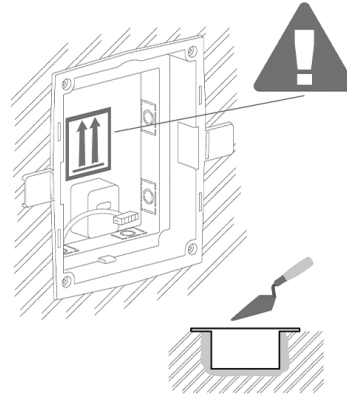

4.

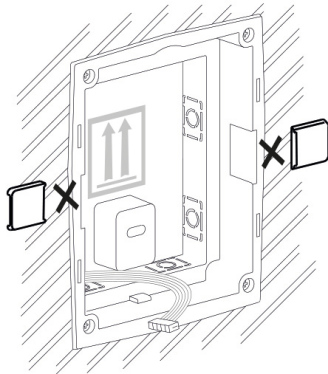

5.

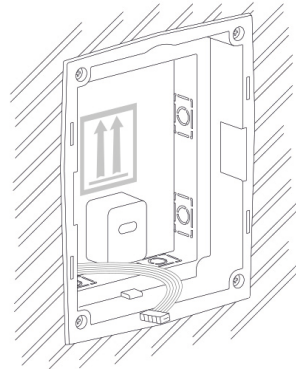

WARNING

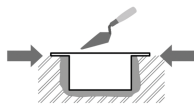

Make sure that the flush mounting box edges are not aligned with the wall but overlap the wall surface. When the proper box installation instructions are not met, water might get in and destroy the device installed. Side stops are used for a correct wall position.



CAUTION

When the walling material has hardened, break off the side stops.

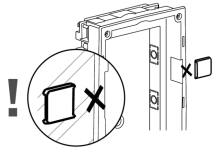

1-Module Installation into Box

1.

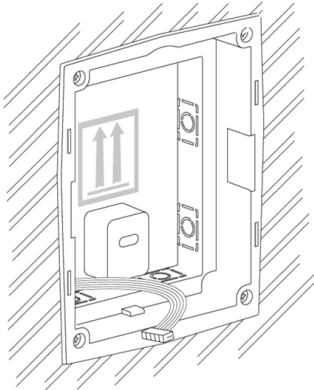

2.

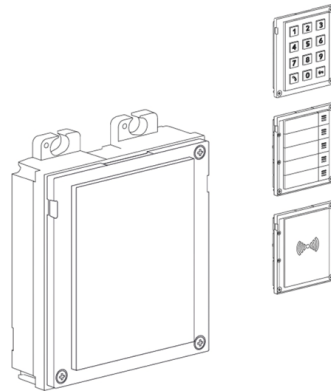

3.

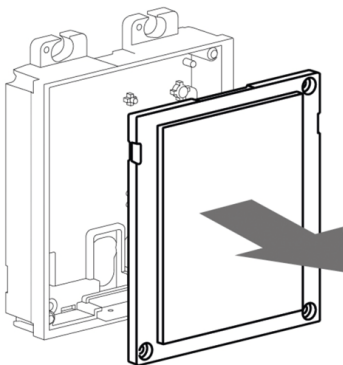

4.

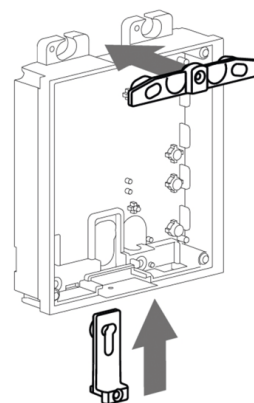

Installation

5.

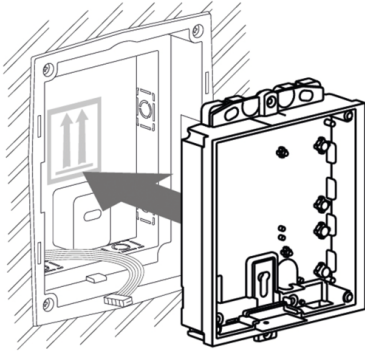

6.

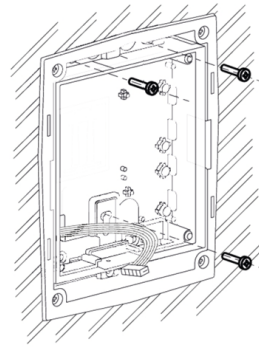

7.

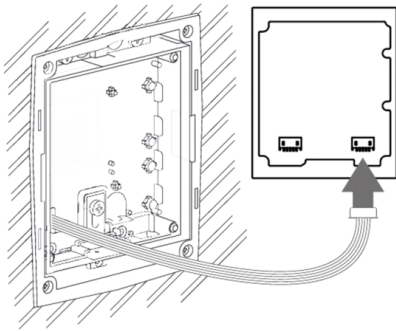

8.

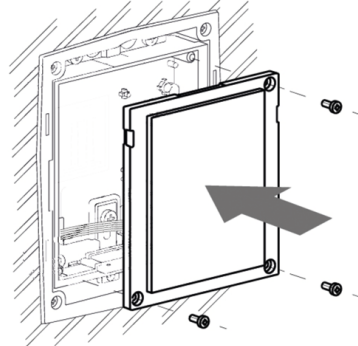

9.

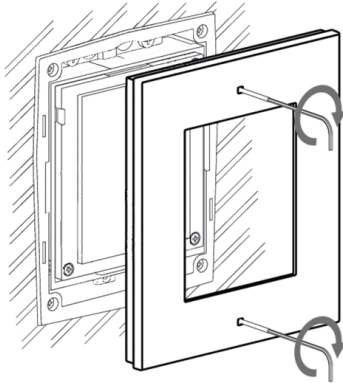

10.

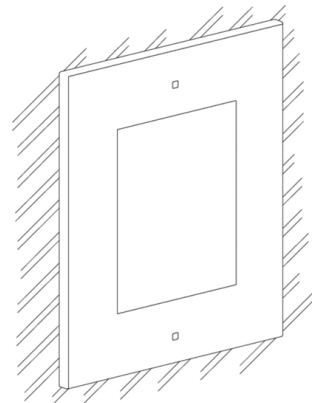

Flush mounting – into plasterboard

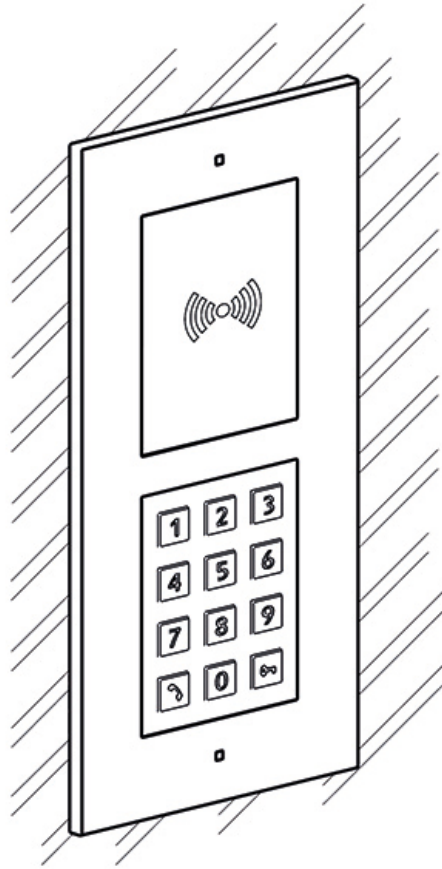

What you need for mounting:

- **2N IP Verso**
- a properly cut hole as instructed in the box package
- flush mounting box and frame
 - for 1-modules: box (9155014, 01284-001) frame (9155011/9155011B, 01278-001/01279-001)
 - for 2-modules: box (9155015, 01285-001), frame (9155012/9155012B, 01280-001/01281-001)
 - for 3-modules: box (9155016, 01286-001), frame(9155013/9155013B, 01282-001/01283-001)



NOTE

The one-module frame is designed for stand-alone installations of extending modules such as OUT readers, etc. A 2-module frame is required for the main unit installation.

To install a device **2N IP Verso** into a wall, mount the flush mounting box first. Then install the device into it.

2-Module Installation

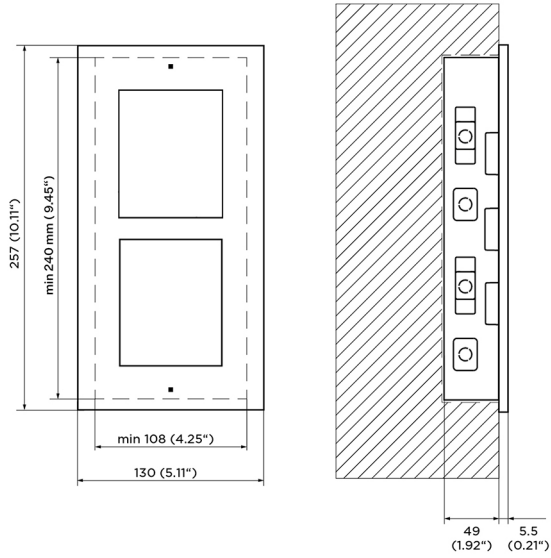

Box Installation

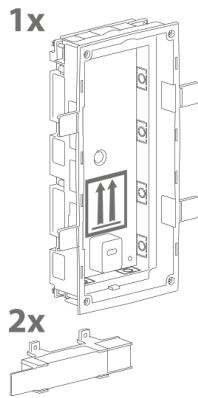

1.

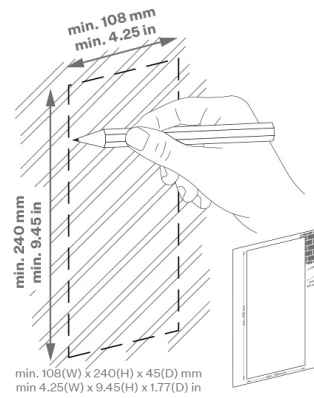

2.

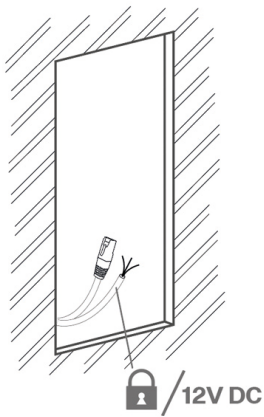

3.

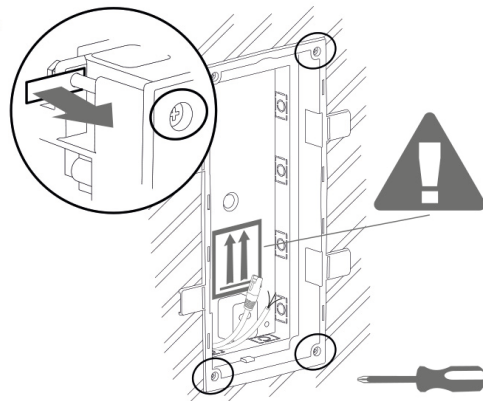

Installation

4.

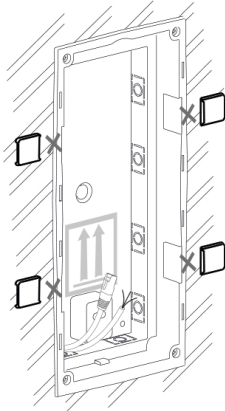

5.

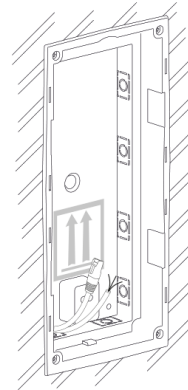

WARNING

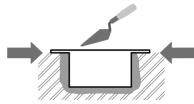

Make sure that the flush mounting box edges are not aligned with the wall but overlap the wall surface. When the proper box installation instructions are not met, water might get in and destroy the device installed. Side stops are used for a correct wall position.



CAUTION

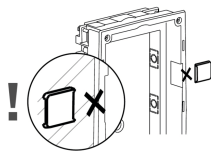

When the walling material has hardened, break off the side stops.

2-Module Installation into Box

1.

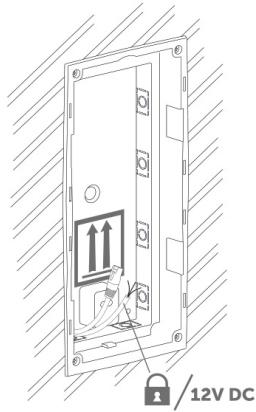

2.

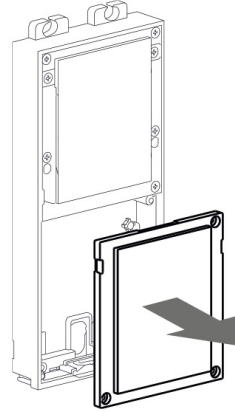

3.

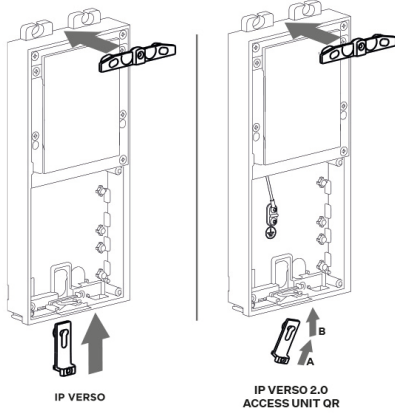

4.

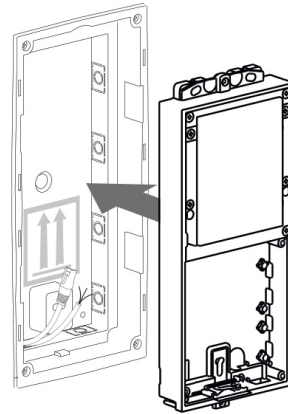

5.

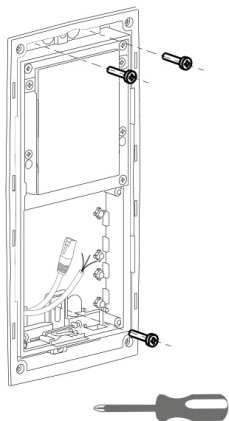

6.

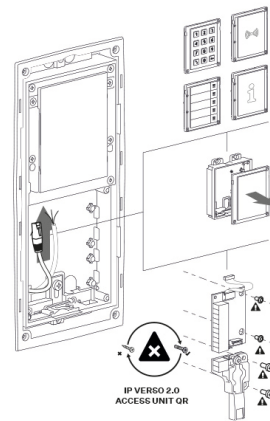

Installation

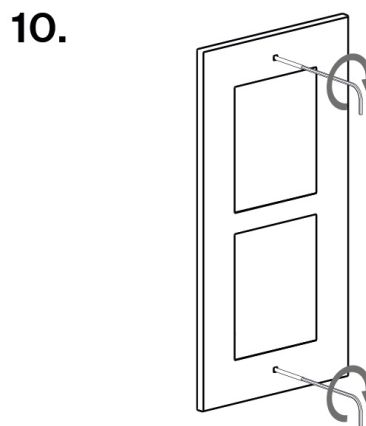
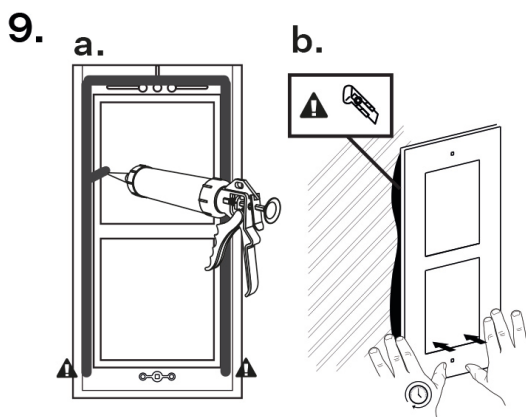
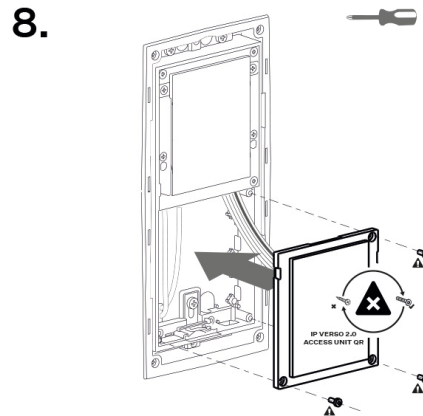
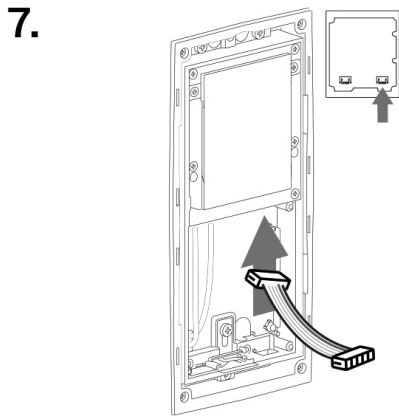

Frame Attachment

Check the frame sealing before fitting the frame.

Screw the flush mounting frame in the upper and bottom parts.

Hang the surface mounting frame on the hook in the upper part and then screw it tight in the bottom part.

Installation of Multiple 2-Module Boxes Next to Each Other

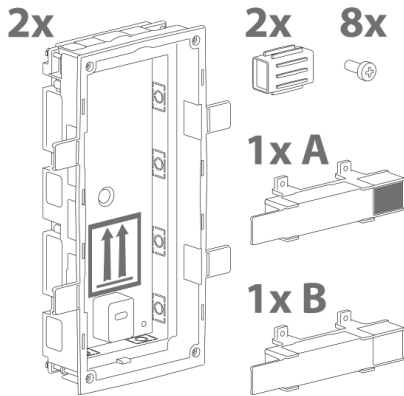
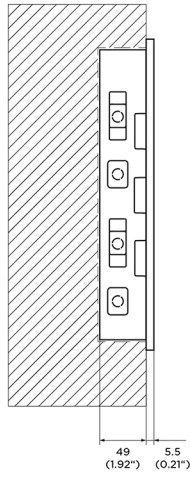
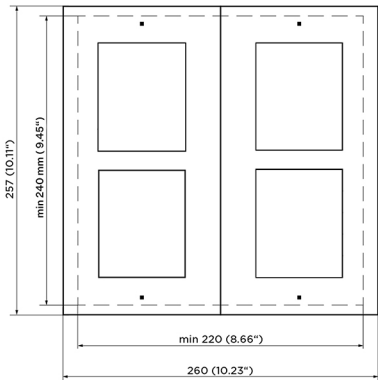

1.

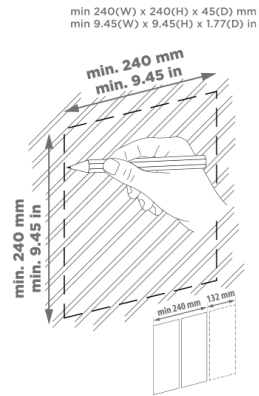

2.

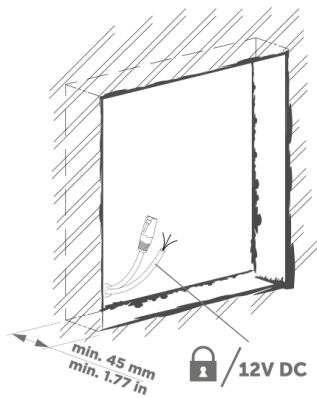

3.

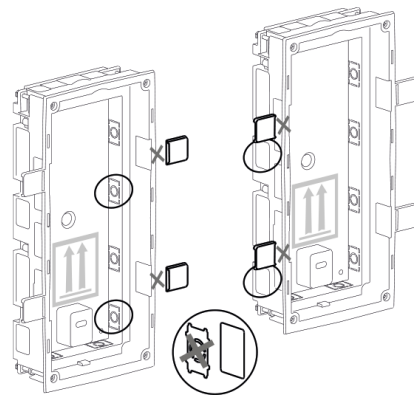

Installation

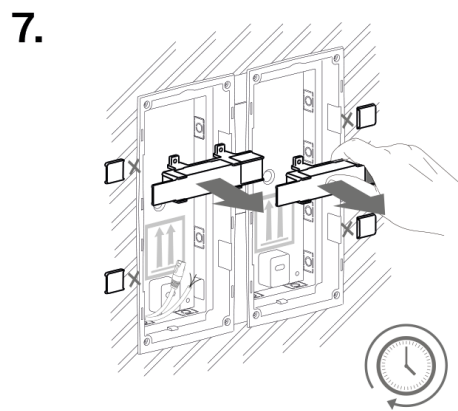
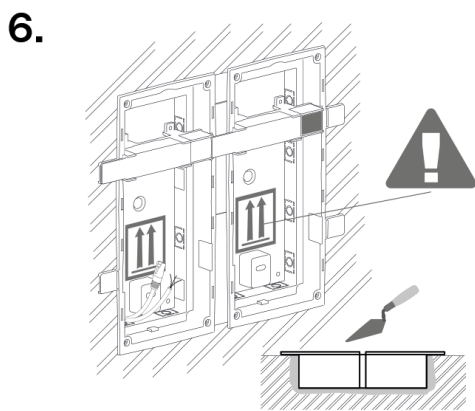
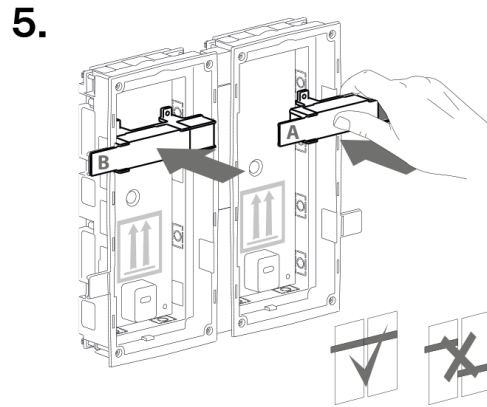
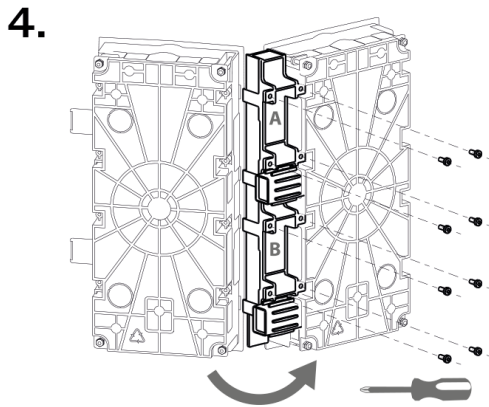

WARNING

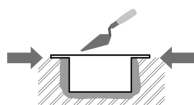

Make sure that the flush mounting box edges are not aligned with the wall but overlap the wall surface. When the proper box installation instructions are not met, water might get in and destroy the device installed. Side stops are used for a correct wall position.



CAUTION

When the walling material has hardened, break off the side stops.

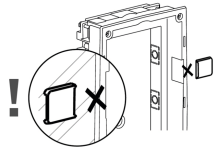

Installation of Multiple 2-Modules into Box

1.

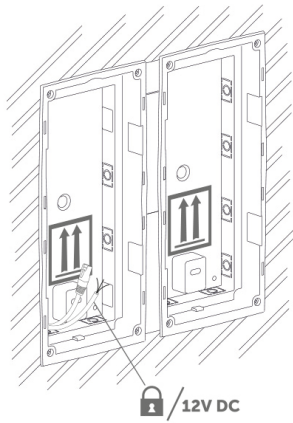

2.

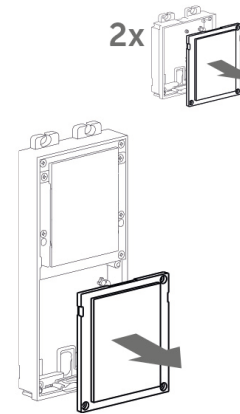

3.

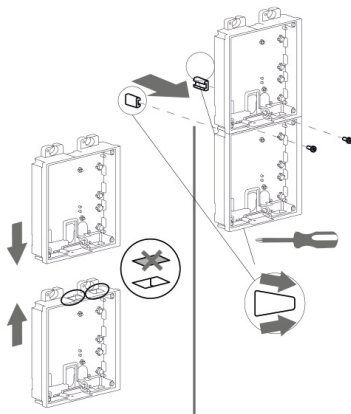

4.

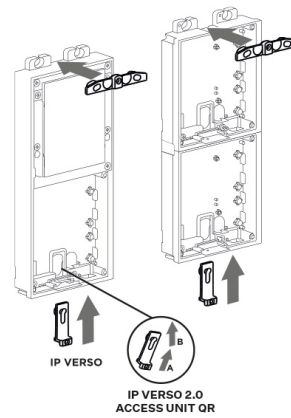

Installation

5.



6.

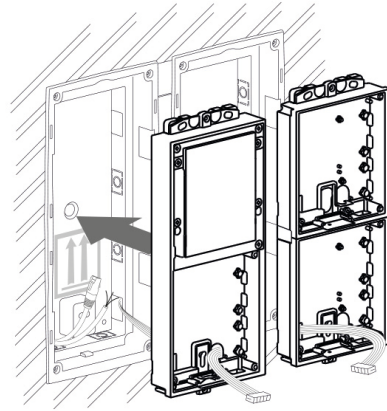

7.

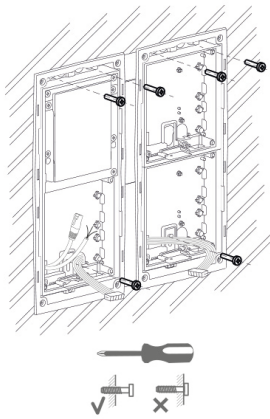

8.

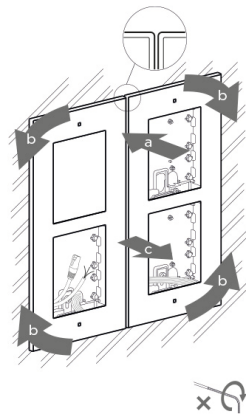

9.

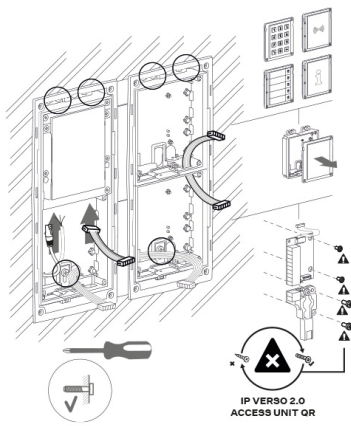

10.

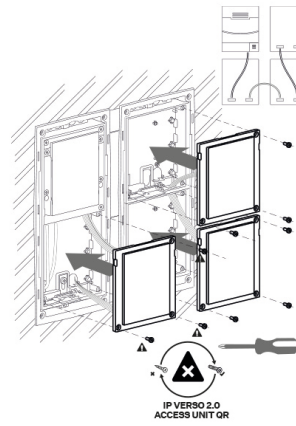

Installation

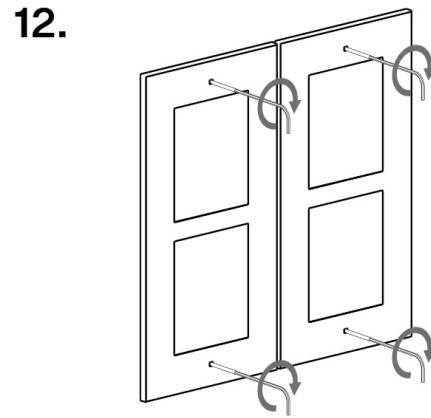
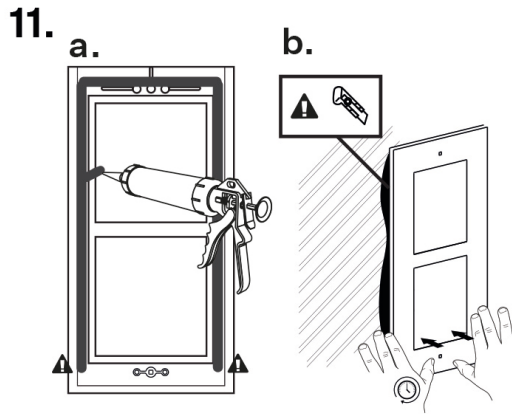

3-Module Installation

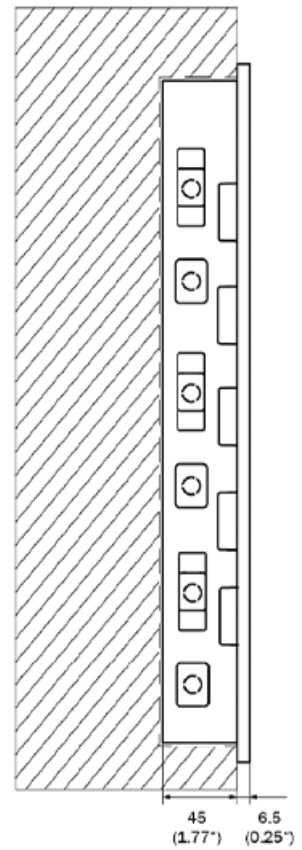
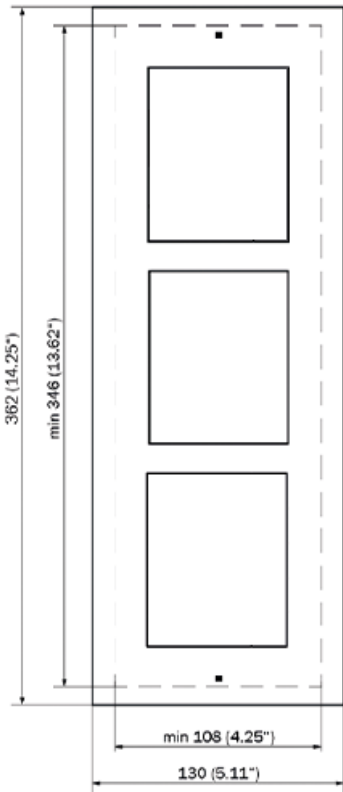

Box Installation

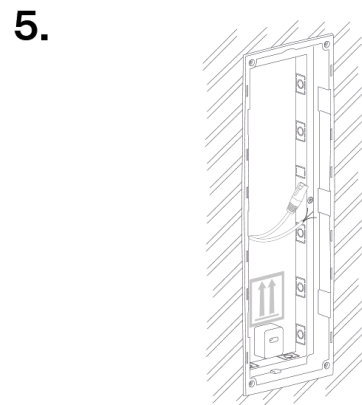
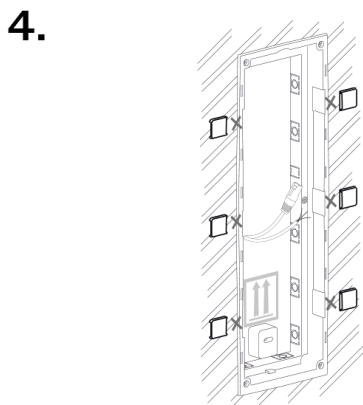
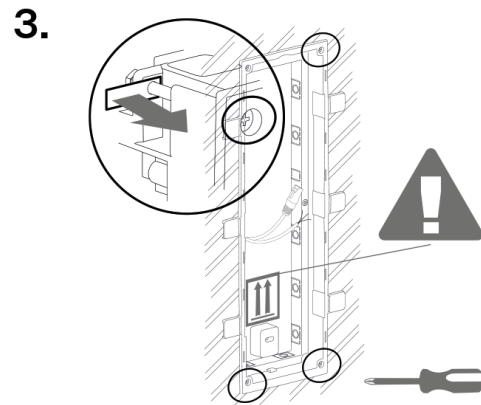
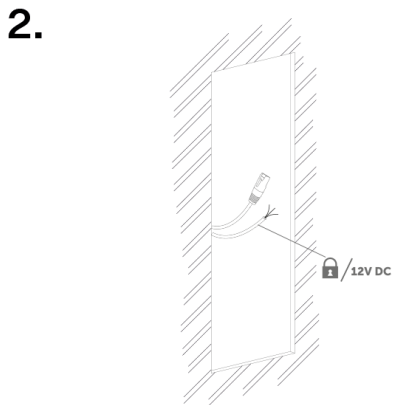
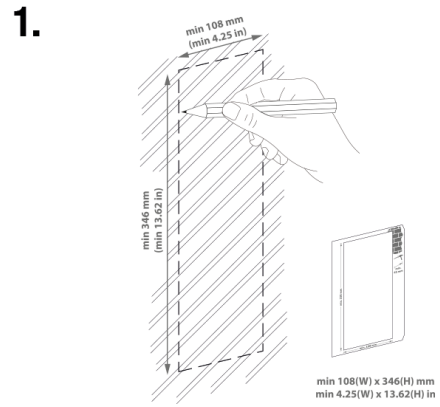
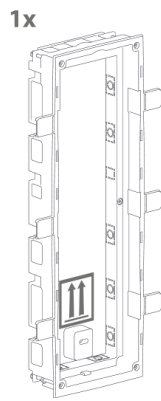



WARNING

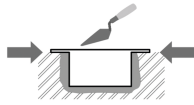

Make sure that the flush mounting box edges are not aligned with the wall but overlap the wall surface. When the proper box installation instructions are not met, water might get in and destroy the device installed. Side stops are used for a correct wall position.



CAUTION

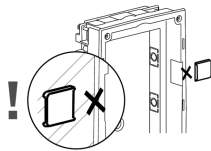

When the walling material has hardened, break off the side stops.

Installation of Multiple 3-Module Boxes Next to Each Other

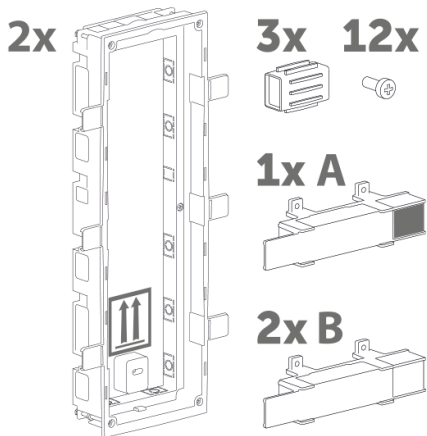
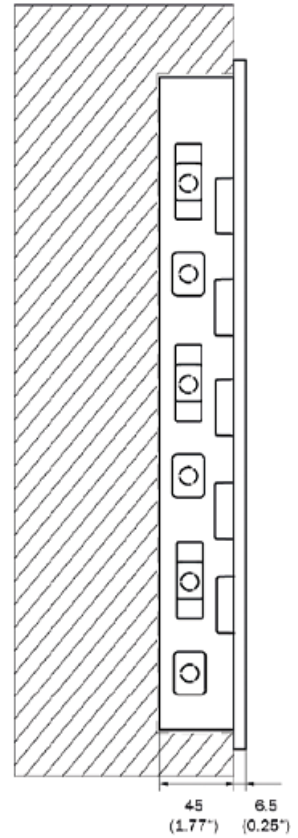
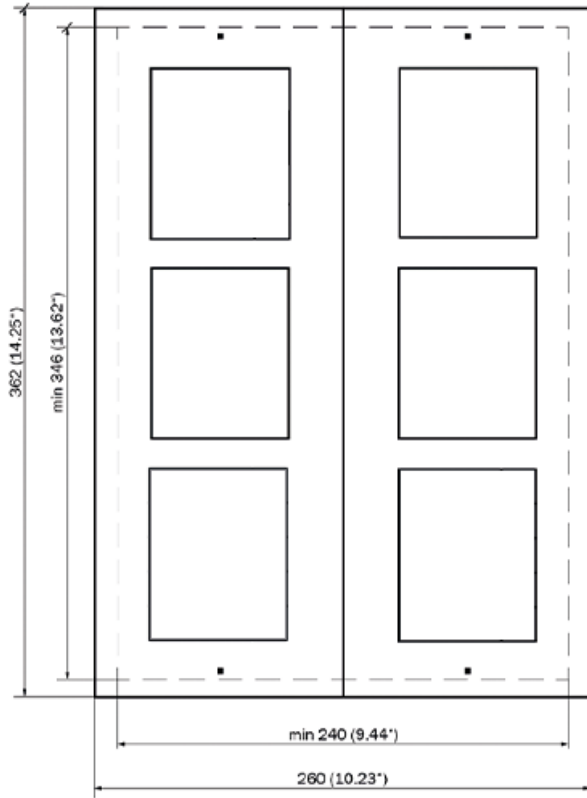

1.

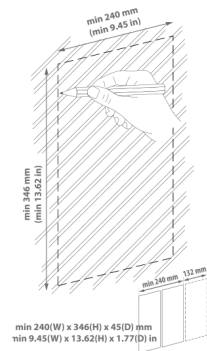

Installation

2.

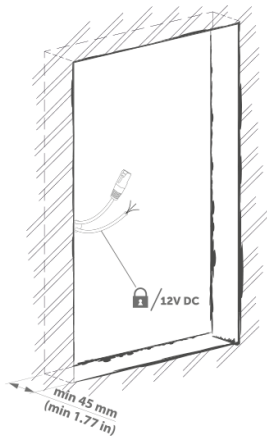

3.

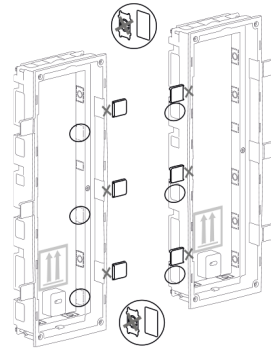

4.

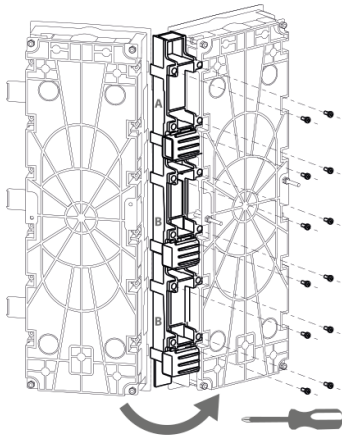

5.

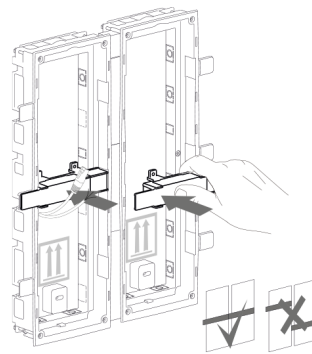

6.

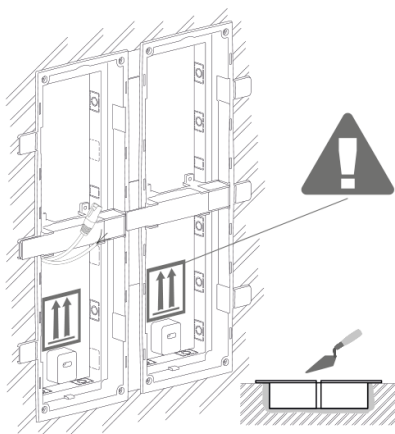

7.

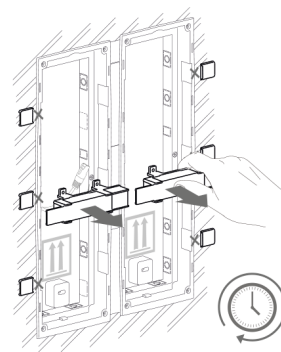

8.

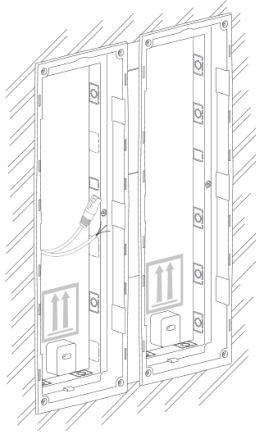

WARNING

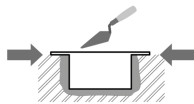

Make sure that the flush mounting box edges are not aligned with the wall but overlap the wall surface. When the proper box installation instructions are not met, water might get in and destroy the device installed. Side stops are used for a correct wall position.



CAUTION

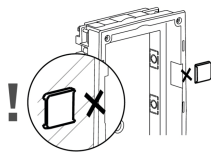

When the walling material has hardened, break off the side stops.

3-Module Installation into Box

1.

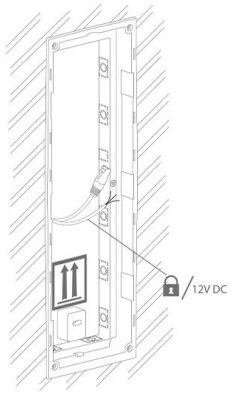

2.

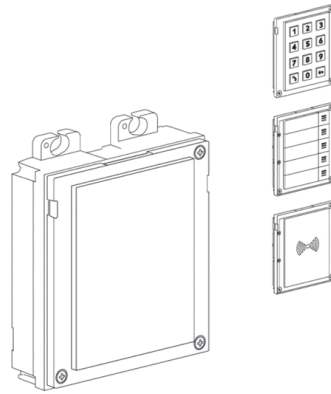

3.

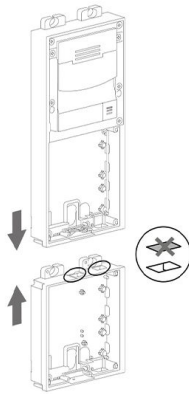

4.

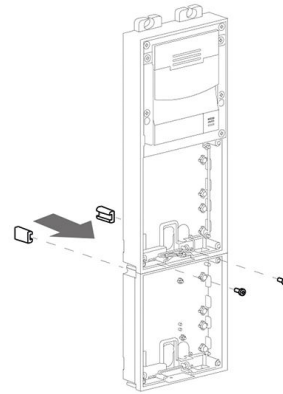

5.

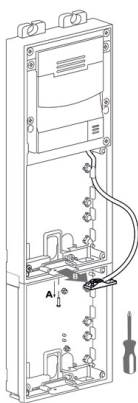

6.

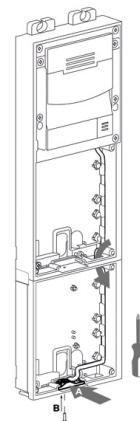

Installation

7.

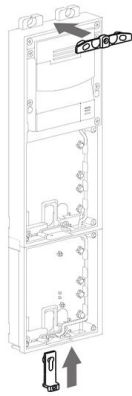

8.

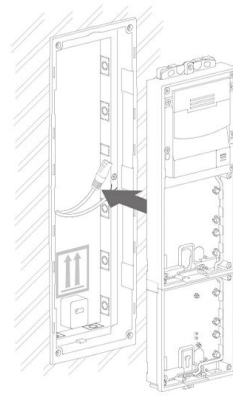

9.

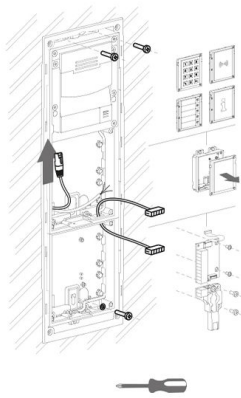

10.

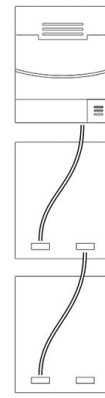

11.

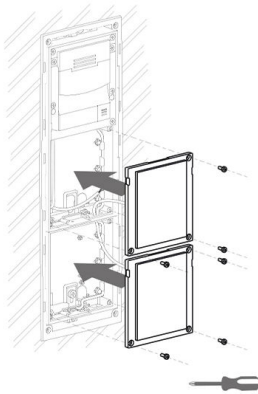

12.



Frame Attachment

Check the frame sealing before fitting the frame.

Screw the flush mounting frame in the upper and bottom parts.

Hang the surface mounting frame on the hook in the upper part and then screw it tight in the bottom part.

1-Module Installation

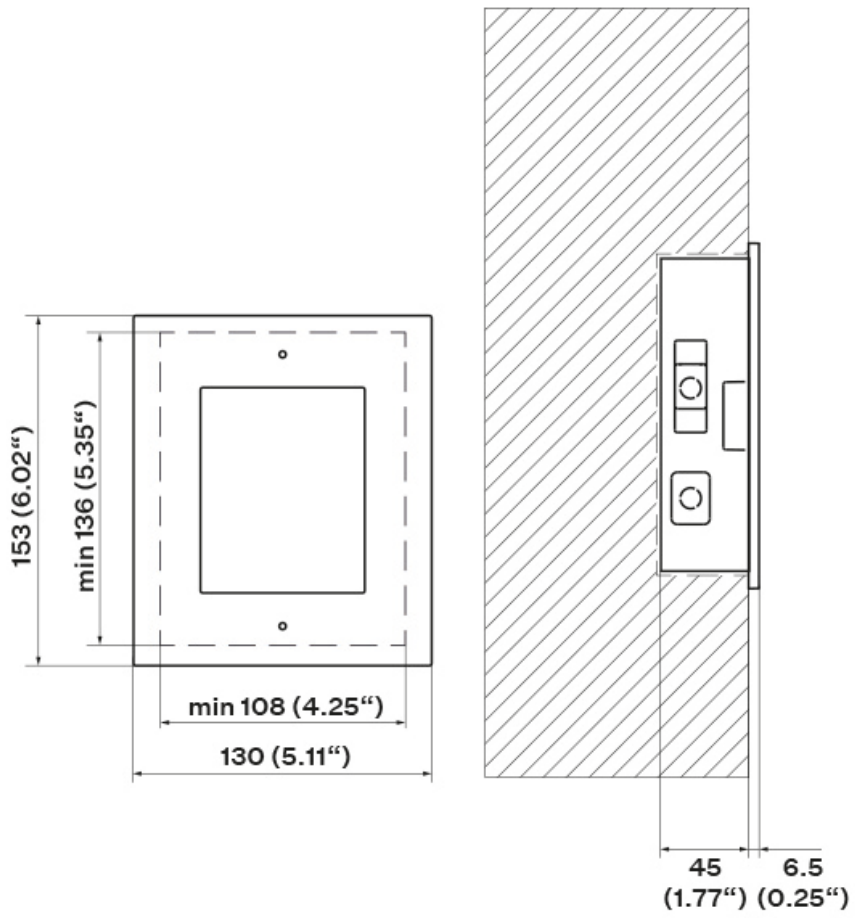

Box Installation

1x

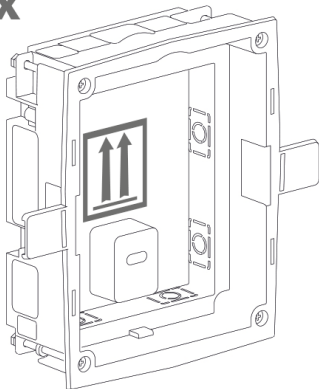

1.

min 108(W) x 136(H) x 45(D) mm
min 4.25(W) x 5.35(H) x 1.77(D) in

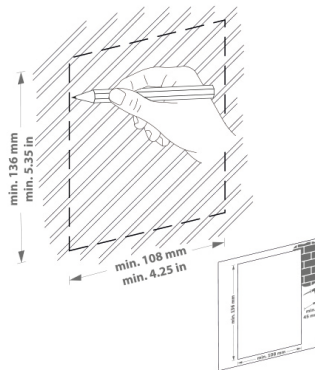

Installation

2.

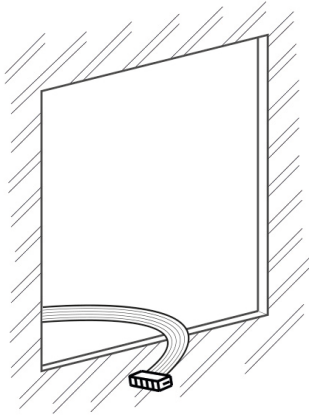

3.

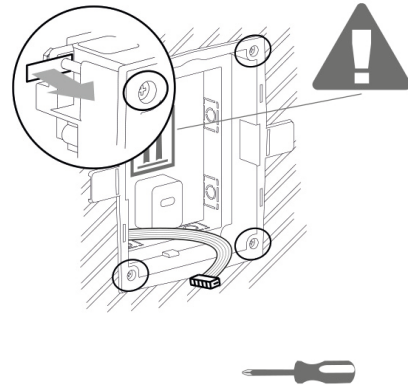

4.

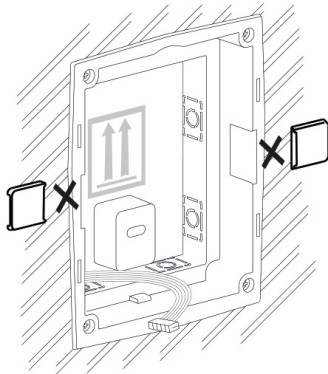

5.

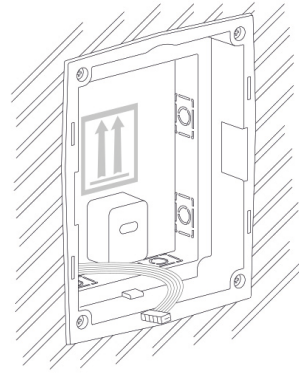

WARNING

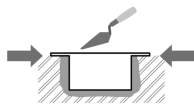

Make sure that the flush mounting box edges are not aligned with the wall but overlap the wall surface. When the proper box installation instructions are not met, water might get in and destroy the device installed. Side stops are used for a correct wall position.



CAUTION

When the walling material has hardened, break off the side stops.

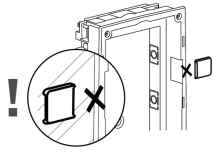

1-Module Installation into Box

1.

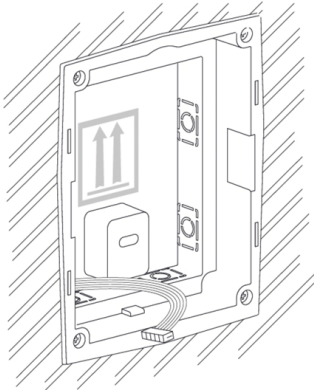

2.

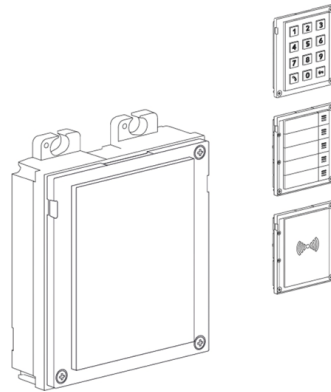

3.

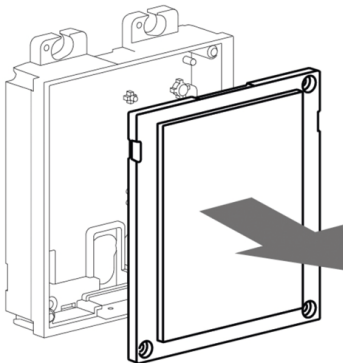

4.

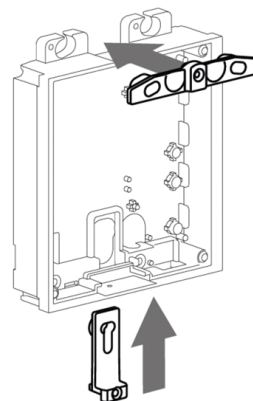

5.

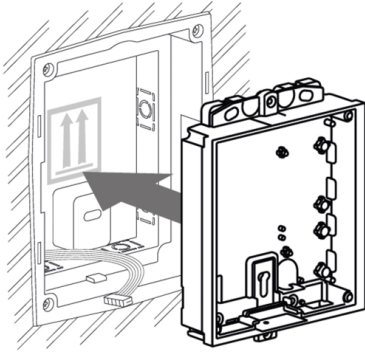

6.

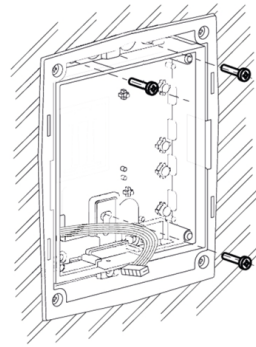

7.

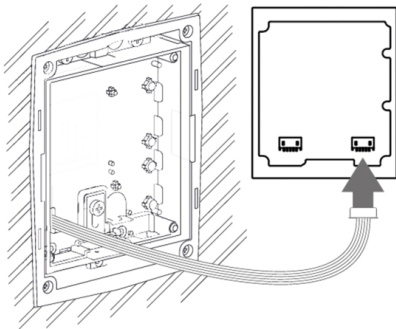

8.

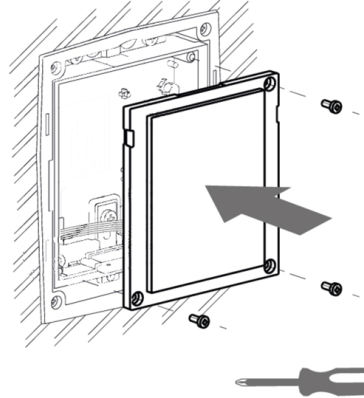

9.

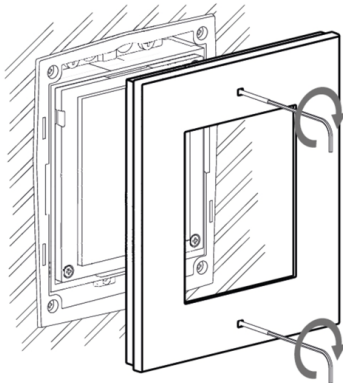

10.

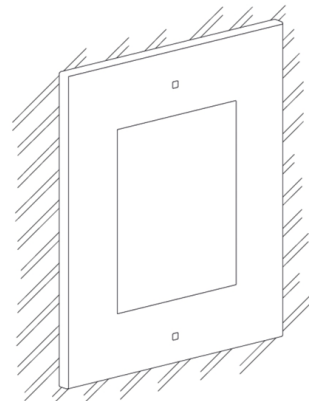

Frame Attachment

Check the frame sealing before fitting the frame.

Screw the flush mounting frame in the upper and bottom parts.

Hang the surface mounting frame on the hook in the upper part and then screw it tight in the bottom part.

Surface Installation

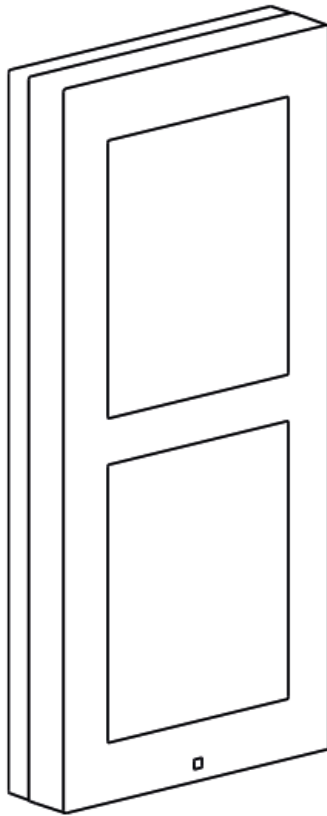

What you need for mounting:

- **2N IP Verso**
- drilling template
- a proper frame
 - for 1-modules: frame (9155021/9155021B, 01287-001/01288-001)
 - for 2-modules: frame (9155022/9155022B, 01289-001/01290-001)
 - for 3-modules: frame (9155023/9155023B, 01291-001/01292-001)



NOTE

The one-module frame is designed for stand-alone installations of extending modules such as OUT readers, etc. A 2-module frame is required for the main unit installation.

For uneven surfaces, use a backplate for the required count of modules (9155061/9155062, 01293-001/01294-001).



DANGER

Eliminate the risk of personal injury! Surface installation is not recommended for narrow passages or places where people's attention is distracted by something else. The manufacturer shall not be liable for injuries in such cases!



WARNING

- Make sure that the installation surface is flat with a maximum inequality of 0.5 mm. (e.g. prefabricated boards, glass, cut stone, etc.). If the installation surface is not even, use the flush mounting type or equalize the wall surface with a backplate (9155061/9155062/9155068, 01293-001/01294-001/01305-001) or make the wall surface perfectly flat.

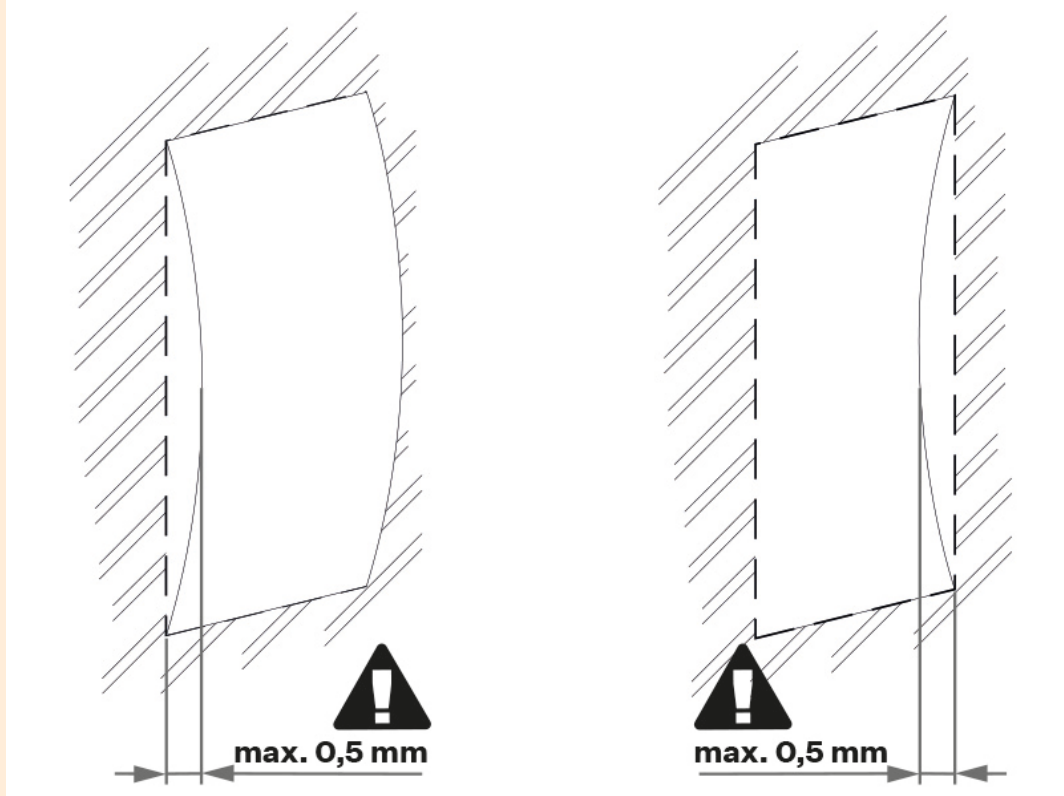

- Surface mounting always poses a problem where the installation is exposed to potential vandalism (such as public garages, etc.). In that case, use steel fixing elements instead of the dowels and screws included in the delivery.

2-Module Installation

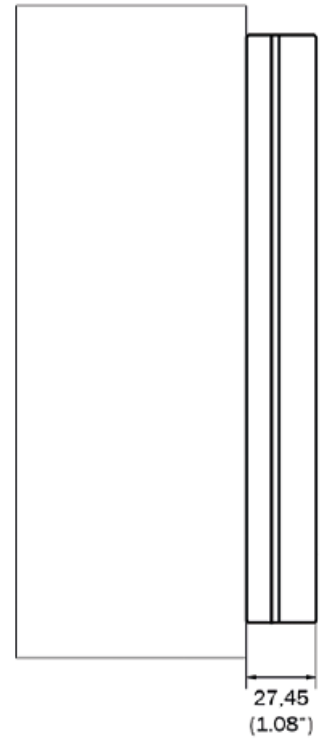
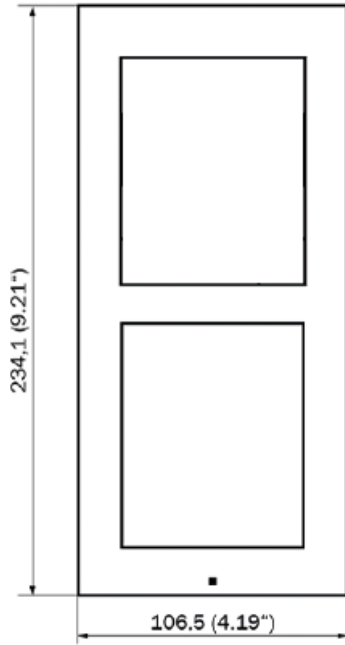

TIP
Download the [drilling template](#) from 2N.com.

1.

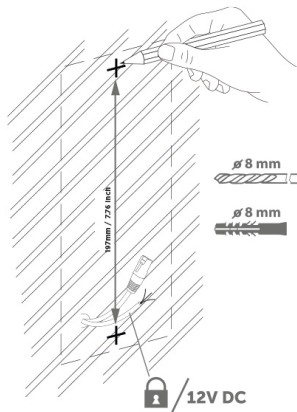

2.

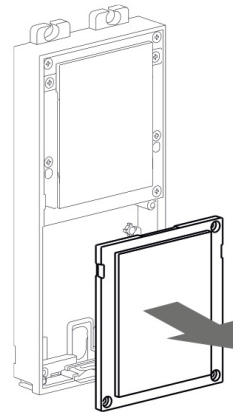

Installation

3.

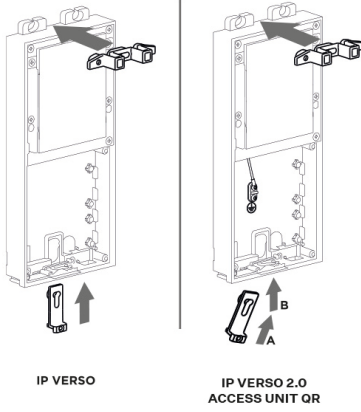

4.



5.

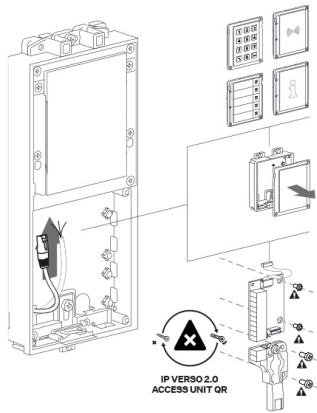

6.

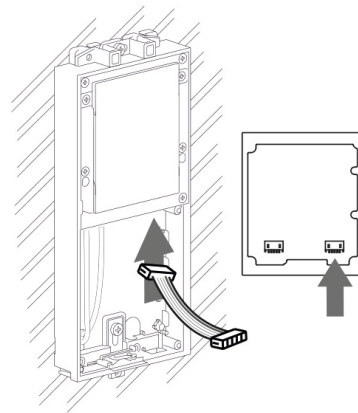

7.

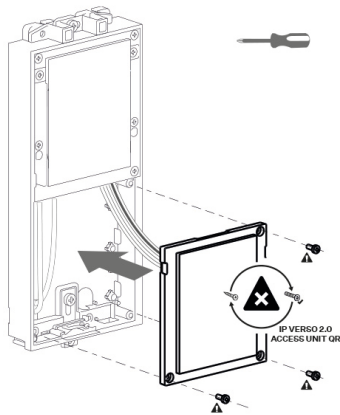

8.

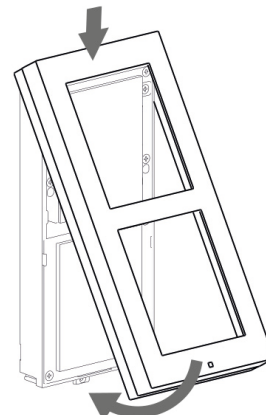

9.

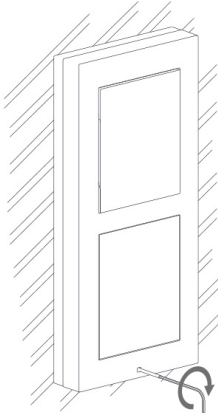

10.

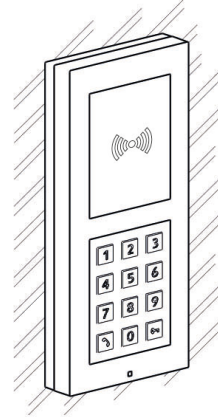

Frame Attachment

Check the frame sealing before fitting the frame.

Screw the flush mounting frame in the upper and bottom parts.

Hang the surface mounting frame on the hook in the upper part and then screw it tight in the bottom part.

Installation of Multiple 2-Modules Next to Each Other

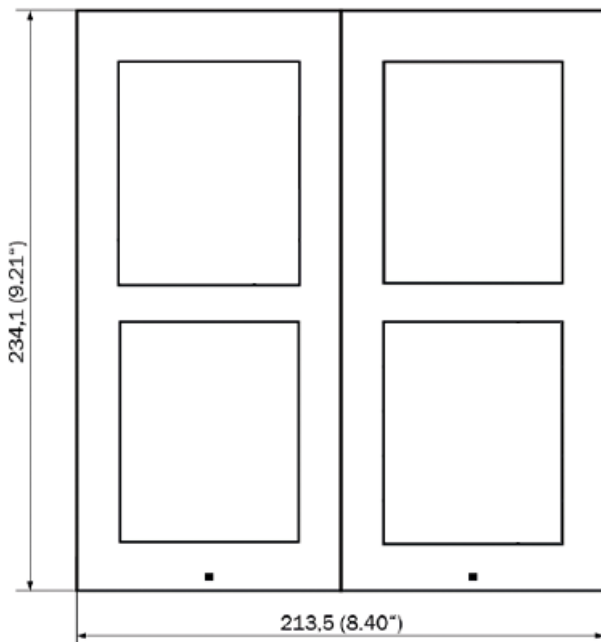

Installation

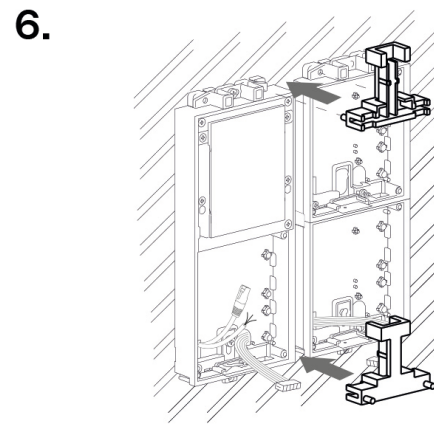
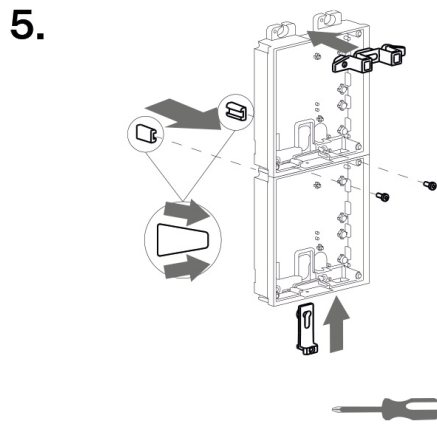
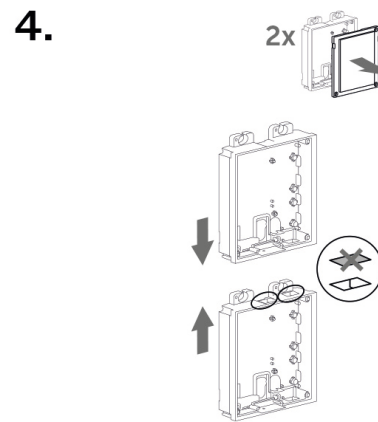
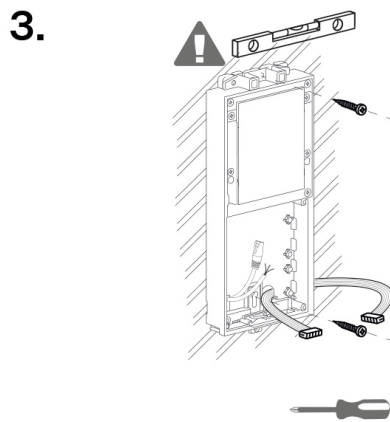
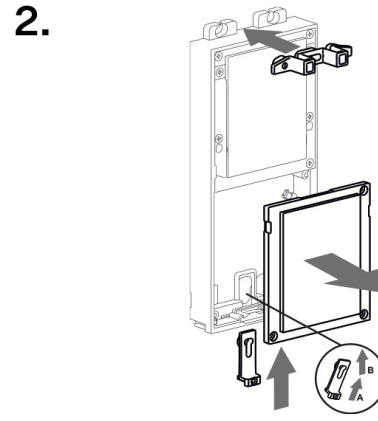
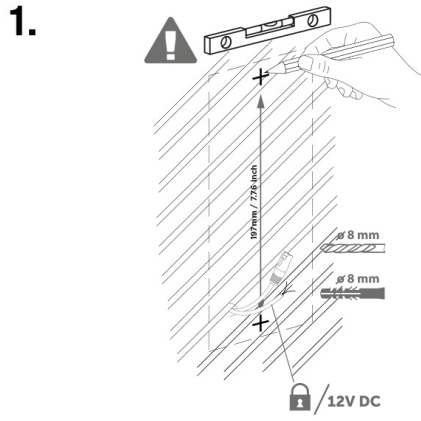

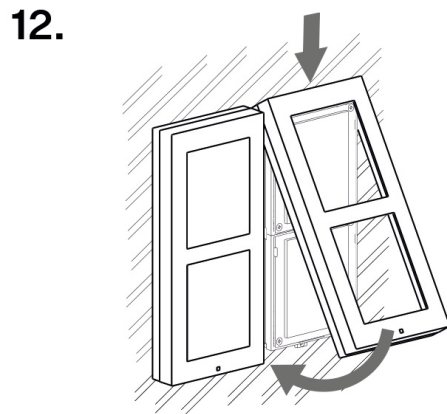
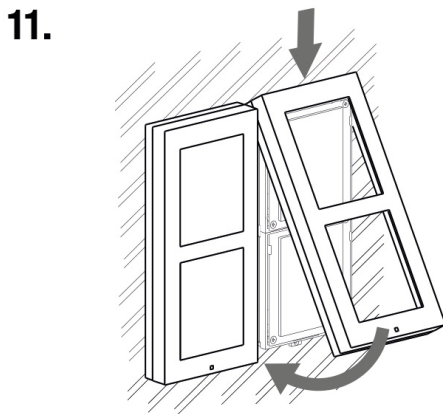
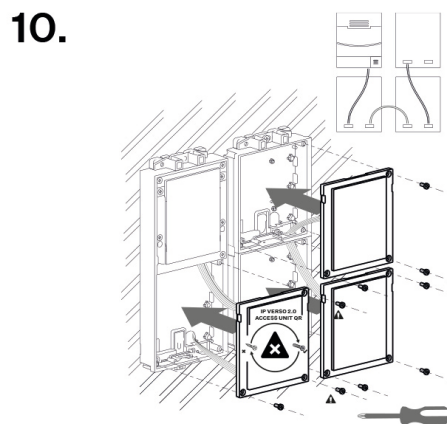
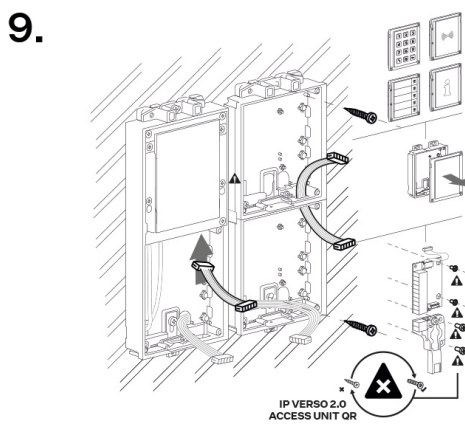
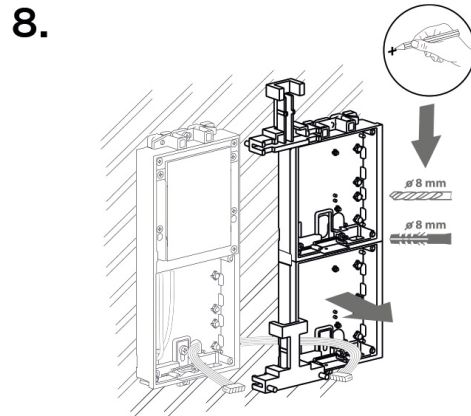
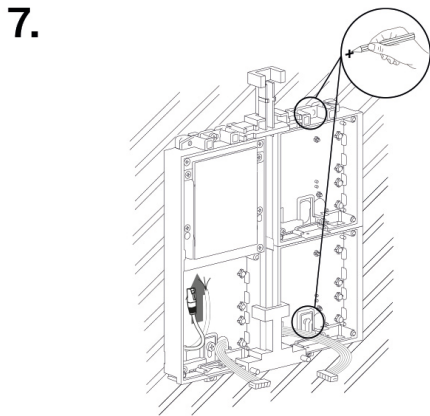

Frame Attachment

Check the frame sealing before fitting the frame.

Screw the flush mounting frame in the upper and bottom parts.

Hang the surface mounting frame on the hook in the upper part and then screw it tight in the bottom part.

3-Module Installation

To install a 3-module, put a 2-module with a 1-module together.

Installation

3.

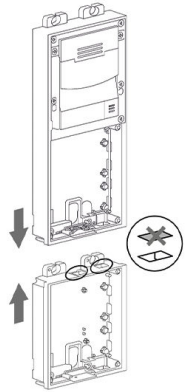

4.

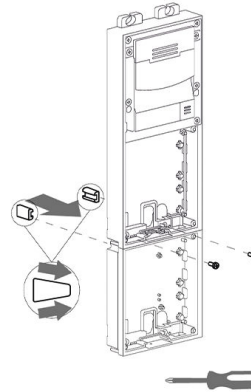

5.

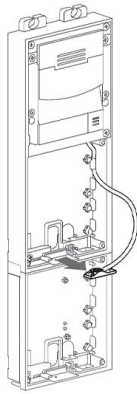

6.

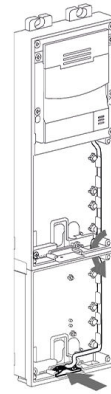

7.

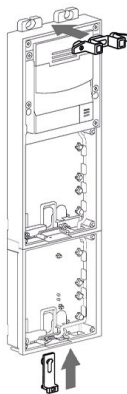

8.

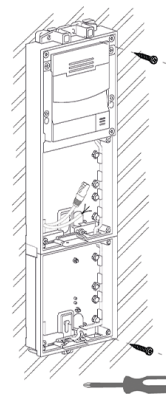

9.

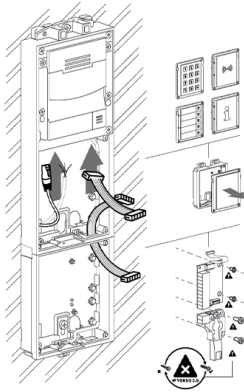

10.

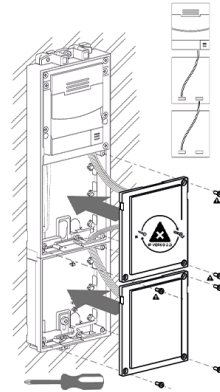

11.

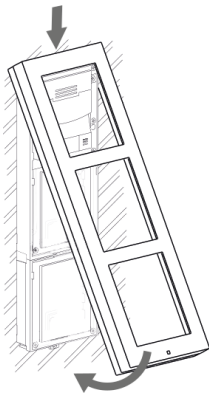

12.



Frame Attachment

Check the frame sealing before fitting the frame.

Screw the flush mounting frame in the upper and bottom parts.

Hang the surface mounting frame on the hook in the upper part and then screw it tight in the bottom part.

Installation of Multiple 3-Modules Next to Each Other

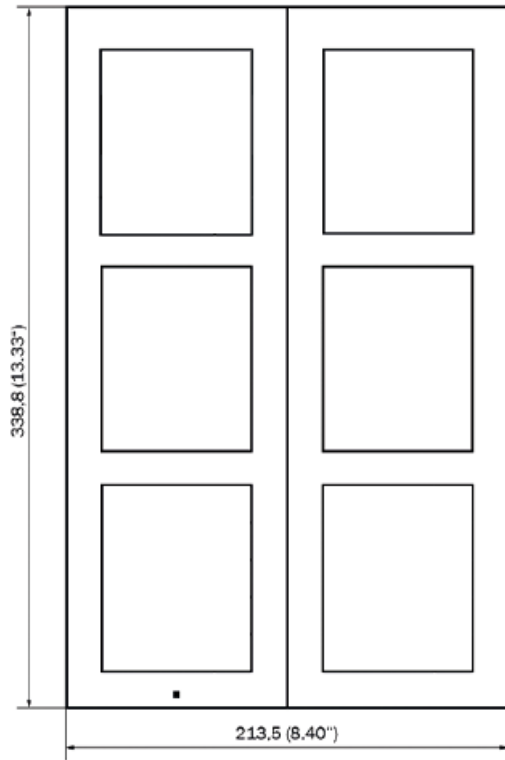

1.

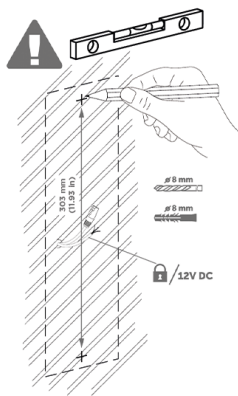

2.

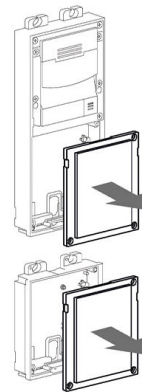

Installation

3.

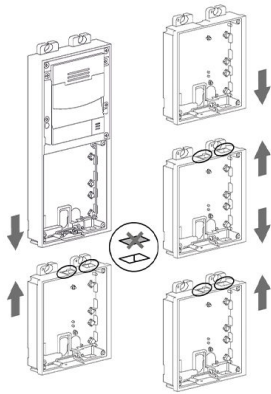

4.

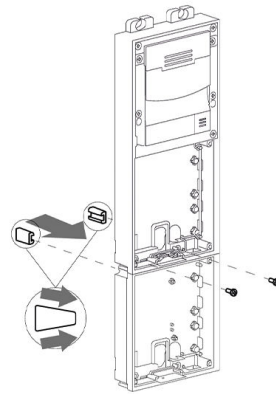

5.

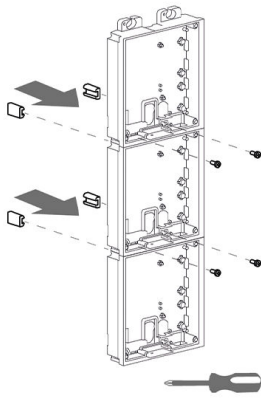

6.

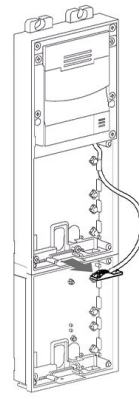

7.

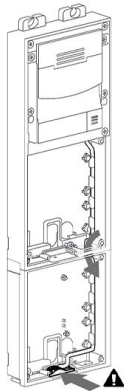

8.

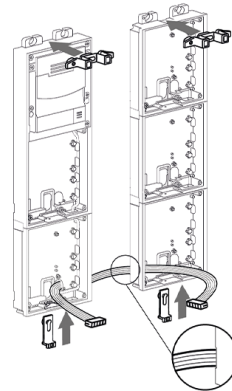

9.

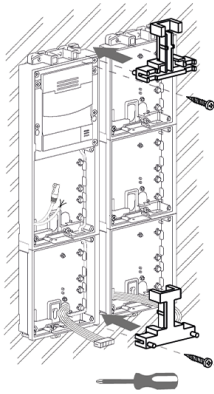

10.

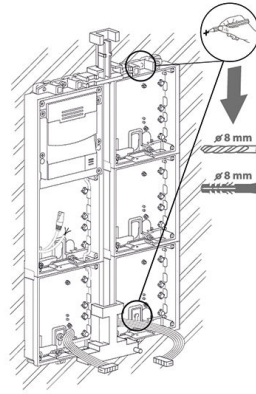

11.

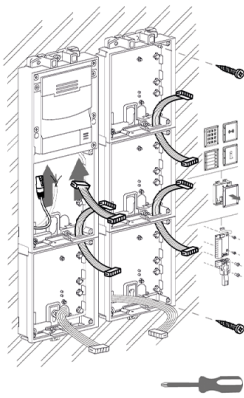

12.

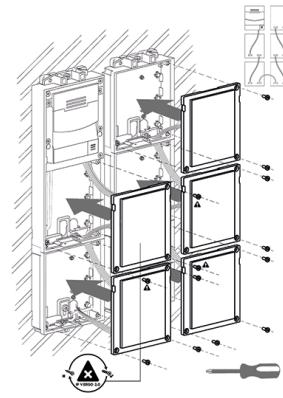

13.

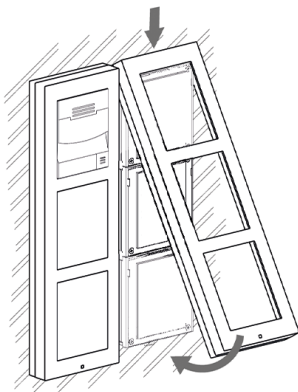

14.



Frame Attachment

Check the frame sealing before fitting the frame.

Screw the flush mounting frame in the upper and bottom parts.

Hang the surface mounting frame on the hook in the upper part and then screw it tight in the bottom part.

1-Module Installation

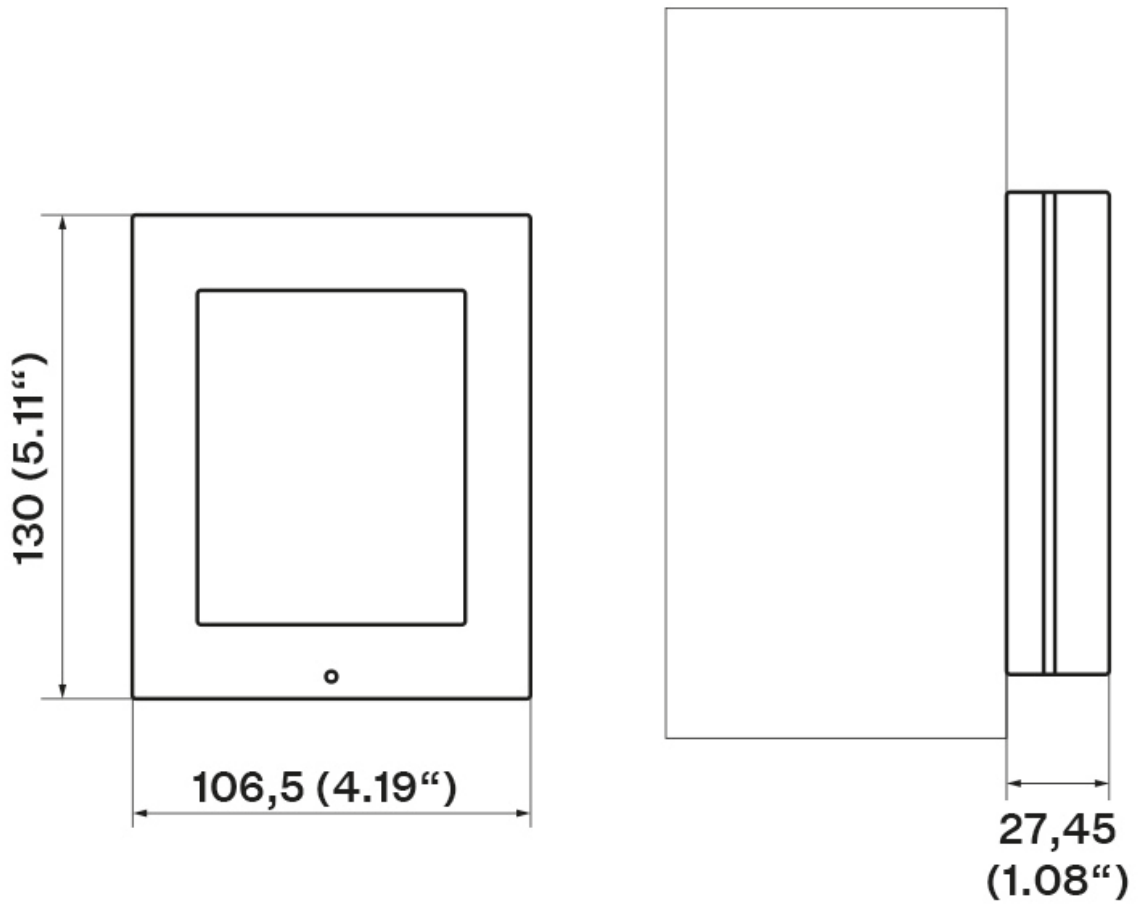

TIP
Download the [drilling template](#) from 2N.com.

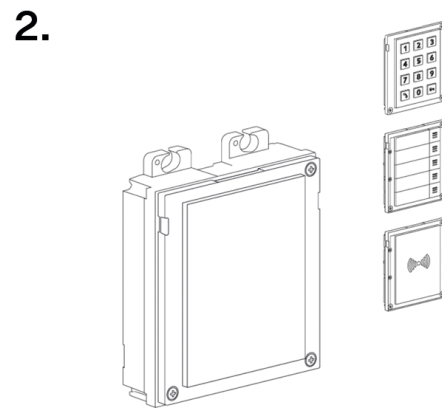
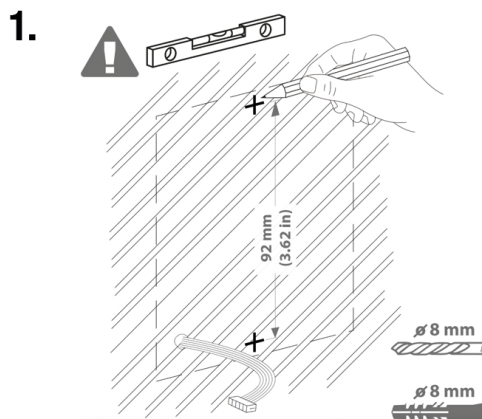

Installation

3.

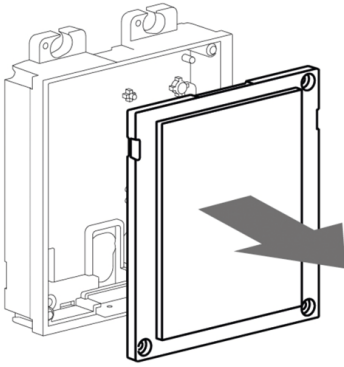

4.

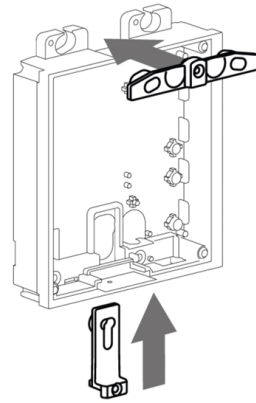

5.

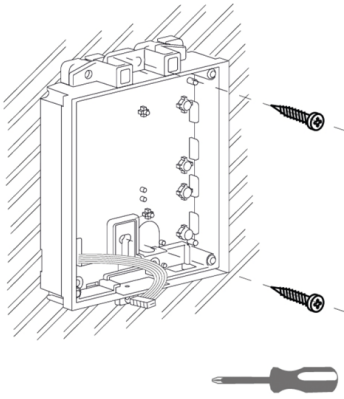

6.

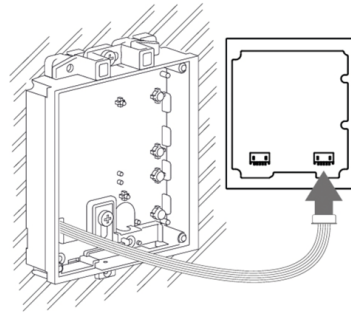

7.

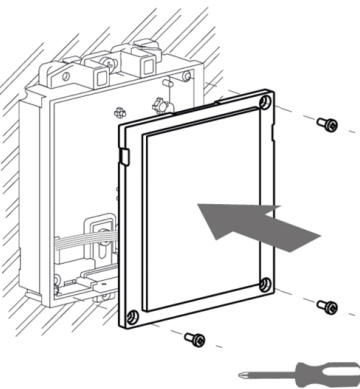

8.

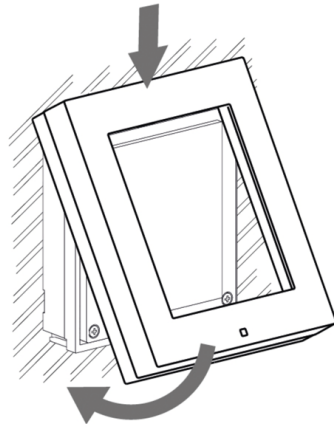

9.

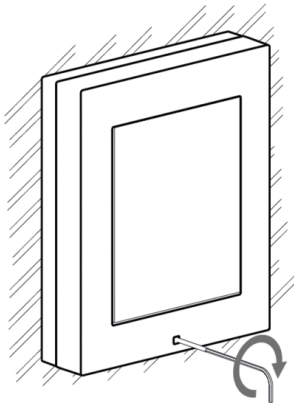

10.

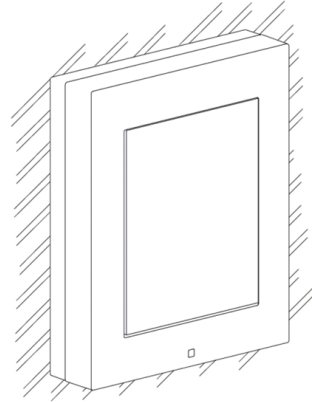

Frame Attachment

Check the frame sealing before fitting the frame.

Screw the flush mounting frame in the upper and bottom parts.

Hang the surface mounting frame on the hook in the upper part and then screw it tight in the bottom part.

Backplate Use

For uneven surfaces, use a backplate for the required count of modules (9155061/9155062, 01293-001/01294-001).

On uneven wall

1.

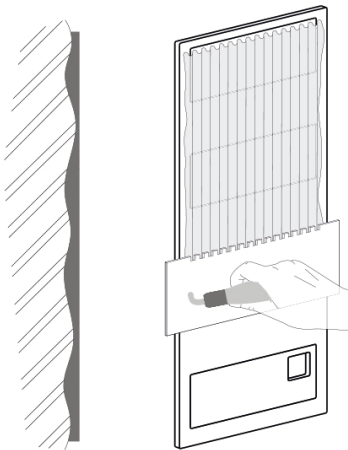

2.

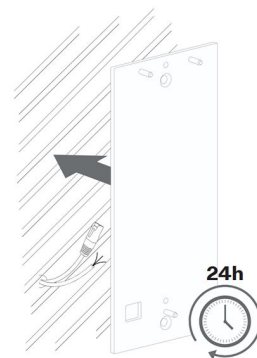

Installation

3.

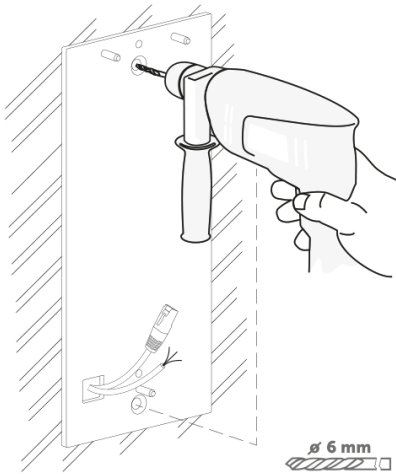

4.

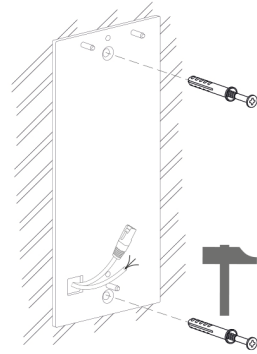

5.

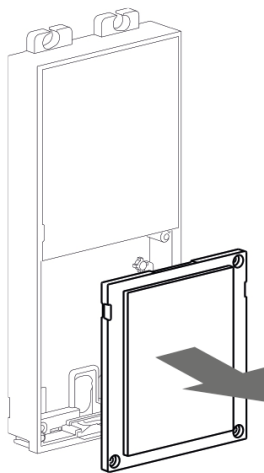

6.

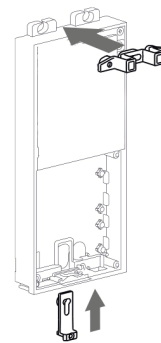

7.

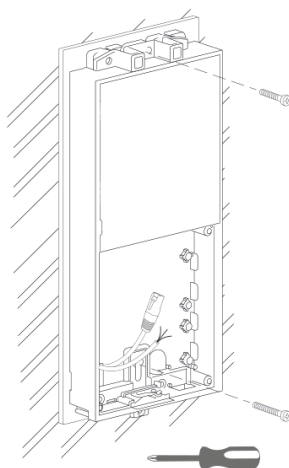

On glass

The backplate for uneven surfaces can also be used for installation on glass.

Installation

1.

4x

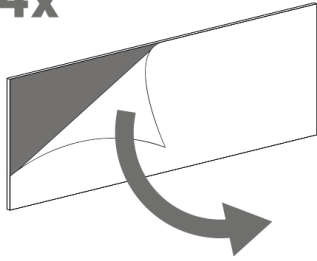

2.

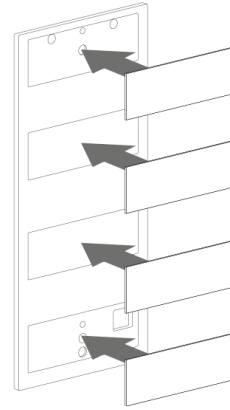

3.

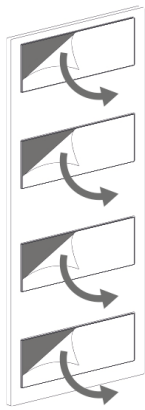

4.

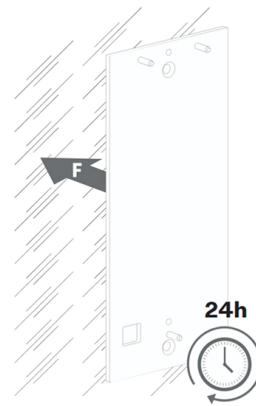

5.

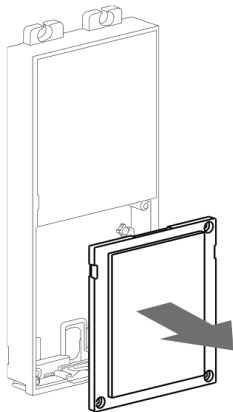

6.

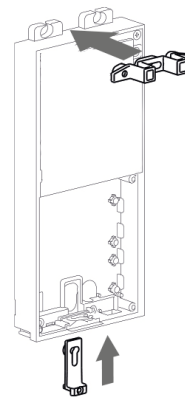

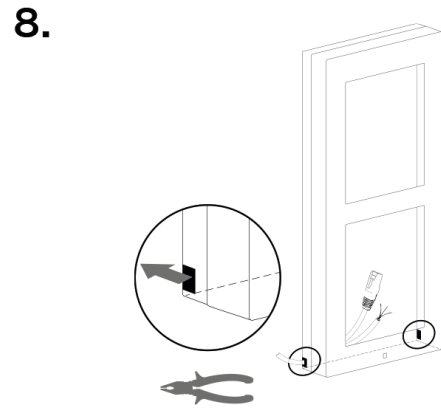
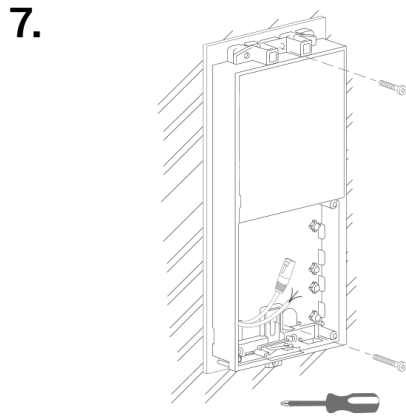

Surface installation on mounting backplate with tilt

The 2-module slope board is used as a backplate for installations with a tilt of 25°.



TIP

Download the [drilling template](#) from 2N.com

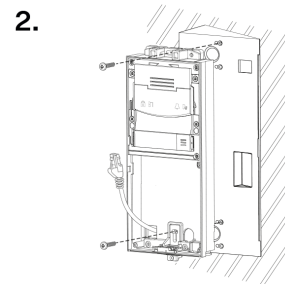
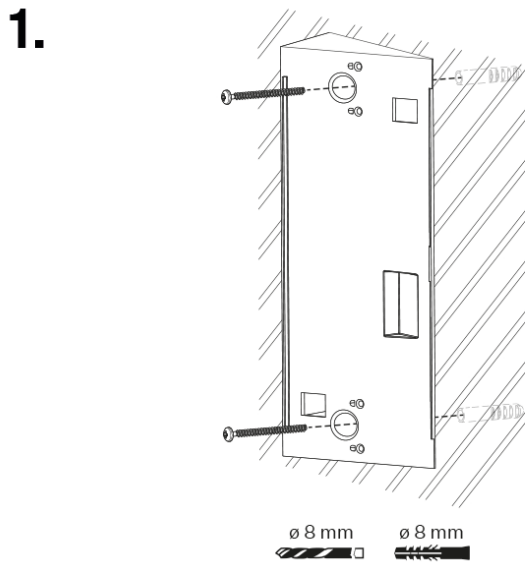

3.

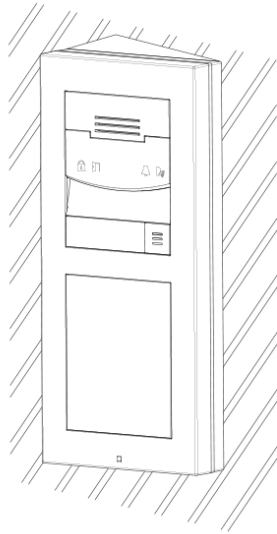

Stand Installation

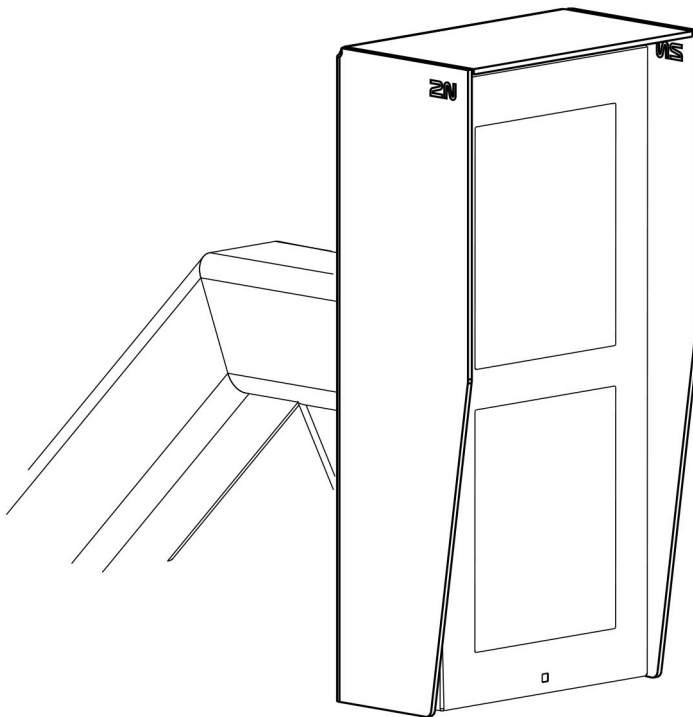

What you need for mounting:

- **2N IP Verso**



CAUTION

Remember to fit the stand to the base thoroughly especially if there is a risk of vandalism (public garages, etc.). Steel fitting elements are recommended.

Installation procedure

1.

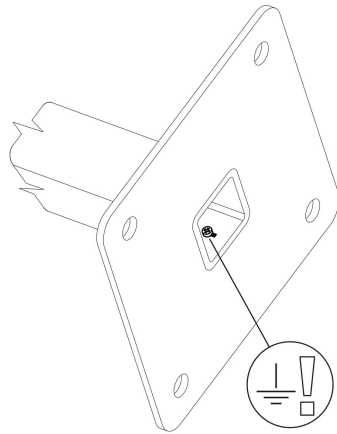

2.

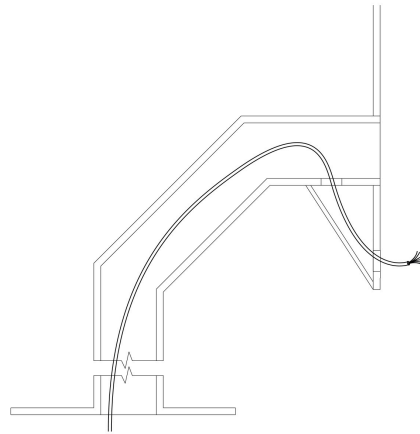

3.

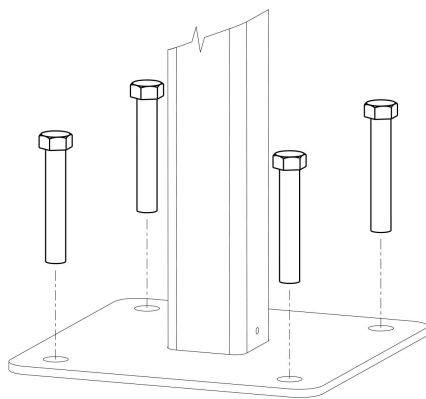

4.

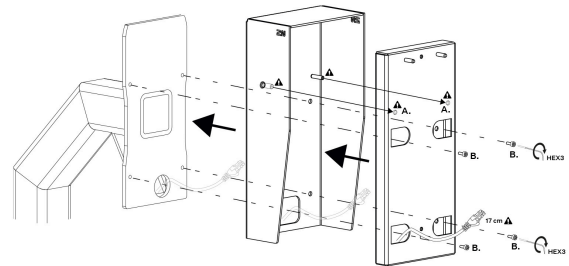

5.

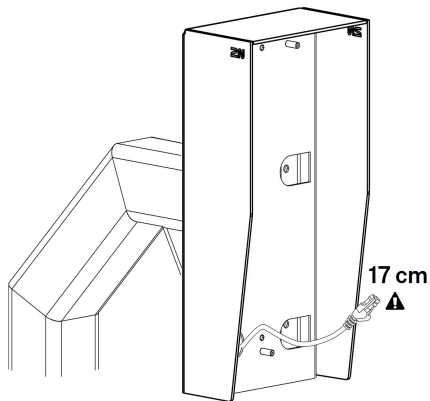

6.

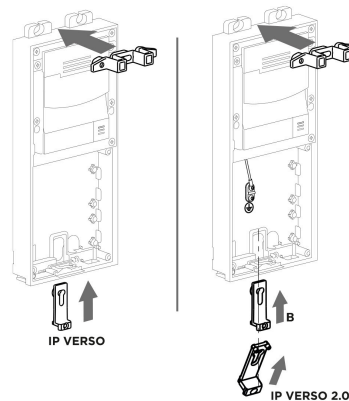

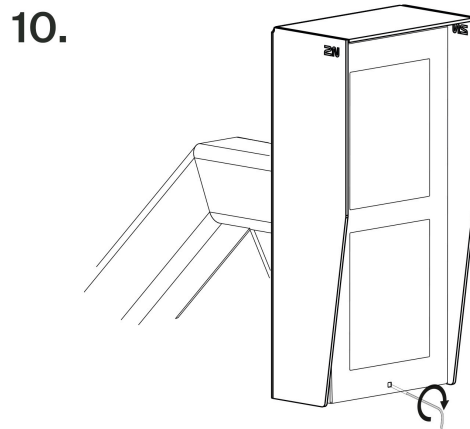
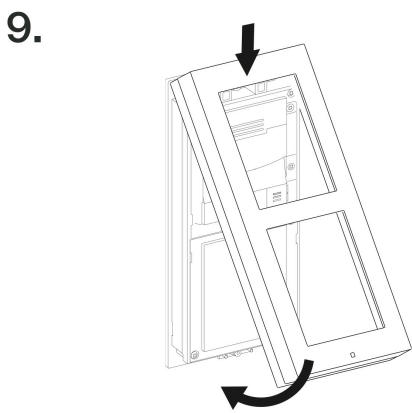
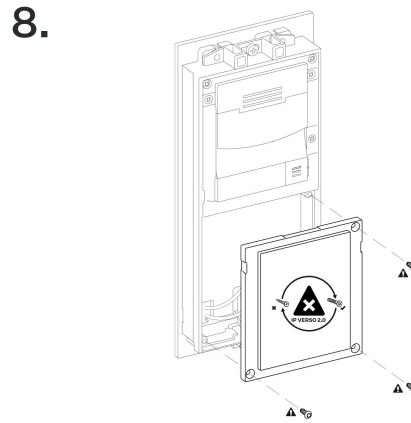
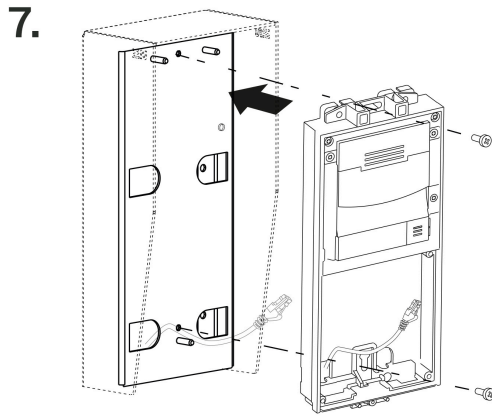

Electric Installation

Power Supply

2N IP Verso can be fed either directly from the LAN if equipped with PoE 802.3af (Class 0, max. 12,95 W) supporting network elements or from an external LPS/PS2 rated, 12 V \pm 15 % / 2 A DC (3 A for multiple modules) power supply.



CAUTION

- The device must be part of the electrical system of the building.
- The external power supply should comply with PS2/LPS.

PoE Supply

2N IP Verso is compatible with the PoE 802.3af (Class 0, max. 12,95 W) technology (Class 0, max. 12.95 W) and can be supplied directly from the LAN via compatible network elements. If your LAN does not support this technology, insert a PoE injector, between **2N IP Verso** and the nearest network element. This power supply provides **2N IP Verso** with 12 W for its own feeding and for connected modules.

External Power Supply

Use a SELV supply LPS/PS2 rated, 12 V \pm 15 % dimensioned to the current consumption according to the required power output for the to make your device work reliably.



CAUTION

Make sure that the wires are firmly attached to the terminal to avoid any free contact.

Current consumption [A]	Available power output [W]
2	24
3	36

Adapter Connection (1341481, 02520-001)

The white wire at the end of the adapter carries the positive charge (+), the black wire carries the negative charge (-).

Combined Power Supply

2N IP Verso can be fed from an external power supply and PoE at the same time. In this configuration, the maximum power for the connected modules is available.

Combined Power Supply

Power Supply Installation

Electric Installation Preparation

1. Unscrew the second module blind on the device base.
2. Use a flat screwdriver to take out the second module blind.

2-Module Electric Installation

1. Place the 2-module base on the flush mounting box / predrilled holes with dowels and pull the power cables through the bottom holes.
2. Insert the metal fitting elements up and down and screw the base plate tight. You can level the base slightly if you are mounting just one base.

3-Module Electric Installation

1. Unscrew the blind on the extending 1-module.
2. Use a flat screwdriver to take out the blind.
3. Slide the 1-module to the 2-module base and secure its position with small side wedges and screws.
4. Remove the microphone from the 2-module and loosen its cable.
5. Lead the microphone (as shown in the [mechanical installation \(p. 37\)](#) figures) into the 1-module base.
6. Place the joined bases on the flush mounting box / predrilled holes with dowels and pull the cables through the bottom holes.
Feed the Ethernet cable without the connector from the extending base to the 2-module base if necessary.

Electric Installation of Multiple Modules Next to Each Other

1. Unscrew the blinds of the extending bases and take them out using a flat screwdriver.
2. Slide the bases into each other as projected and secure their positions with small side wedges and screws.
3. Place the cover on the flush mounting box / predrilled holes with dowels and pull the cables if any through the bottom holes.
4. Pull the bus using the cable bushing available in the flush mounting box.

Device Connectors

Main unit connector wiring

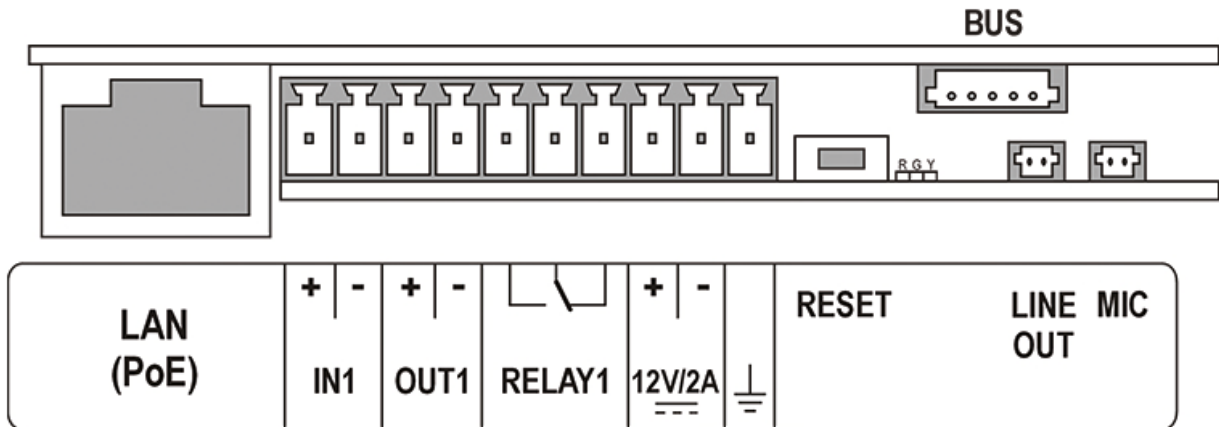

GROUND symbol

Grounding terminal



CAUTION

We recommend that a grounding cable of the cross-section of 1.5 mm² is used.

LAN (PoE)

LAN connector (PoE 802.3af)

Installation

IN1	IN1 terminals for input in passive/ active mode (–30 V to +30 V DC) <ul style="list-style-type: none"> • OFF = open contact or $U_{IN} > 1.5 \text{ V}$ • ON = closed contact or $U_{IN} < 1.5 \text{ V}$
OUT1	OUT1 terminals of active input for Security Relay (p. 135) or electric lock connection: 8 up to 12 V DC depending on power supply (PoE: 10 V; adapter: source voltage minus 2 V), up to 400 mA
12 V / 2 A	External power supply terminals LPS/PS2 rated, 12 V \pm 15 % / 2 A DC (3 A for multiple modules)
RELAY	RELAY1 terminals with accessible 30 V / 1 A AC/DC NO contact.
RGY	LED indicators (red/green/yellow).
RESET	Factory Reset button
BUS	Device bus connector
LINE OUT	External induction loop output. LINE OUT (1 V _{RMS}) connector, type JST SHR-02V-S
MIC	Microphone (MIC) connector

Available switches

Location	Name	Description
Main unit	RELAY1	Passive switch: <ul style="list-style-type: none"> • switching and expandable contact • max. 30 V / 1 A AC/DC • only used to connect non-critical devices (e.g. lights)
	OUT1	Active switch output: <ul style="list-style-type: none"> • 8 – 12 V DC depending on the power supply, max. 400 mA <ul style="list-style-type: none"> • PoE: 10V DC • adapter: source voltage -2 V • 10 to 12 V DC, max. 600 mA

Location	Name	Description
I/O module* (9155034, 01257-001)	Extension relay1	<p>Passive switch:</p> <ul style="list-style-type: none"> • make and break contact • max. 30 V / 1 A AC/DC • only used to connect non-critical devices (e.g. lights)
	Extension relay2	<p>Passive switch:</p> <ul style="list-style-type: none"> • make and break contact • max. 30 V / 1 A AC/DC • only used to connect non-critical devices (e.g. lights)

Multiple modules marked with an asterisk (*) can be used.



DANGER

If a coil containing device is connected, e.g. relays/electromagnetic locks, it is necessary to protect the device output against voltage peak while switching off the induction load. For this way of protection we recommend a 1 A / 1000 V diode (e.g., 1N4007, 1N5407, 1N5408) connected antiparallel to the device.

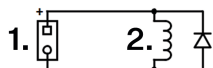

1. Terminals
2. Coil. e.g. relay or electromagnetic lock



WARNING

The 12V output is used for lock connection. If the device is installed in a location where there is a danger of unauthorized access (building front, e.g.), we strongly recommend the use of the 2N Security Relay (9159010, 01386-001) to ensure the maximum installation security.

Relay Terminal Wiring Diagrams

It is possible to connect a device to the **2N IP Verso** relay terminals to be controlled by this relay, e.g. an electric/electromechanical door lock.

The elements are designated as follows in the diagrams below:

1. Device relay

2. Controlled device

Wiring diagram for the relay terminal output for switching the electric circuit of the controlled device

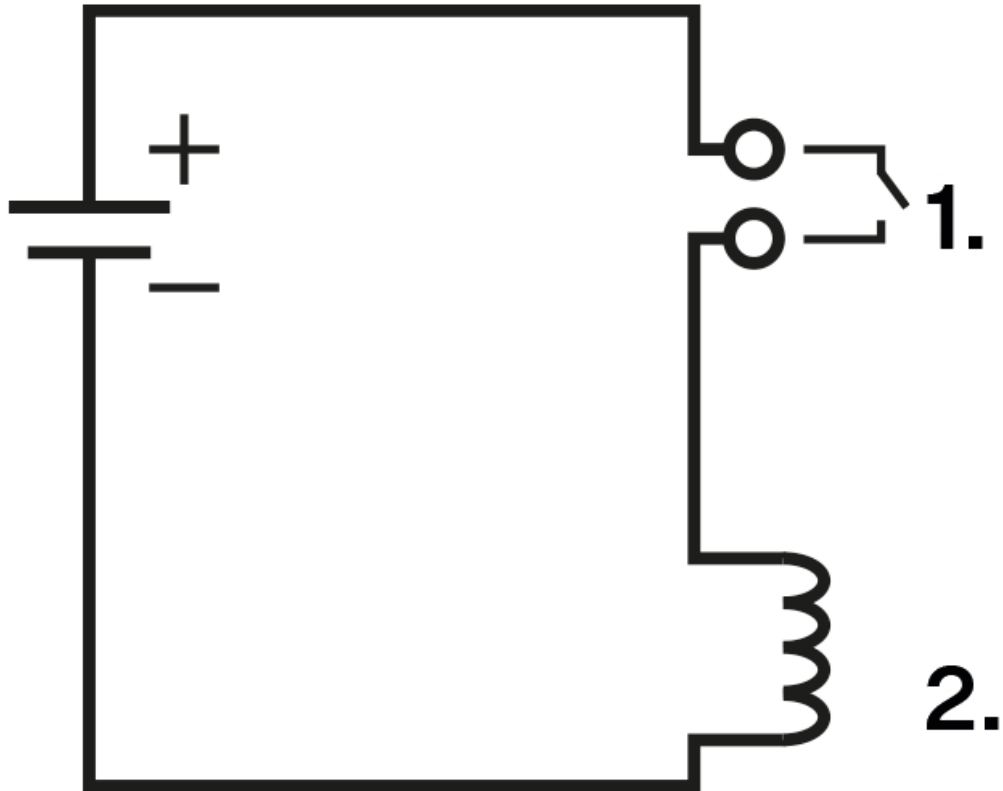

Connection of IN1 inputs (or IN2)

It is possible to connect an external button, e.g. a departure button or door open sensor, to the IN1 or IN2 terminals of device **2N IP Verso**.

The following wiring diagrams apply both to IN1 and IN2.

Wiring diagram of IN1 terminals in active mode

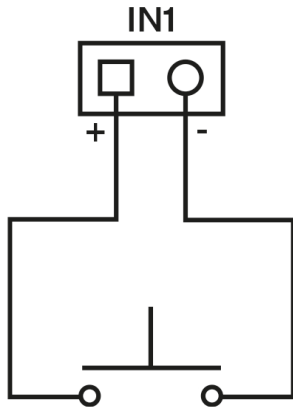

Wiring diagram of IN1 terminals in passive mode

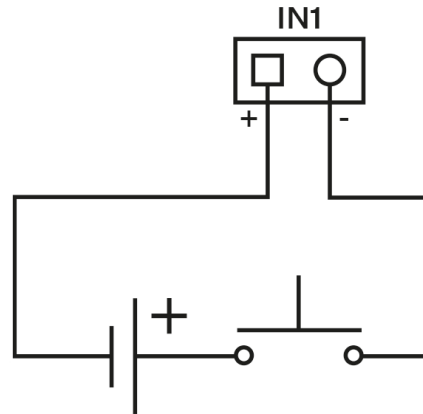

LAN Connection

2N IP Verso is connected to the LAN by inserting a SSTP cable (Cat-5e or higher) terminated with an RJ-45 plug into the marked LAN connector on the device. As the device is equipped with the Auto-MDIX function, you can use either the straight or crossed cable version.

This device must be deployed within a network infrastructure that provides adequate protection against Denial-of-Service (DoS) attacks and similar network-based threats. The device does not include built-in protection against high-volume or malicious traffic and relies on the surrounding network environment—such as firewalls, intrusion prevention systems, or rate limiting—for defense. Failure to implement appropriate network security measures may lead to service degradation or unavailability. The equipment's user documentation shall contain a [description of all exposed network interfaces and all services exposed via network interfaces](#), which are delivered as part of the factory default state.



WARNING

This device cannot be connected directly to telecom lines (or public wireless networks) of any telecom service providers (i.e. mobile providers, landline providers or Internet providers). A router has to be used for the device Internet connection.



CAUTION

- We recommend the use of a LAN [surge protection](#) (p. 110).
- We recommend the use of a shielded SSTP Ethernet cable.



TIP

Remove the protective connector cover to facilitate the threading of the SSTP cable RJ terminal into the device box.

Overvoltage Protection

The 2N device cables have to be protected against atmospheric overvoltage caused by external causes (lightning, e.g.). A surge can damage a device installed outside/inside the building if the wires are unprotected.

Therefore, we recommend that additional overvoltage protectors (OVP) be installed on the outer walls or roof for all the wires leading outside the building. Keep the following instructions while installing overvoltage protectors:

- Make sure that the overvoltage protector is installed as close as possible to the device installed outside the building.
- Make sure that the overvoltage protector is installed as close as possible to the device installed on an external part of the building.
- Make sure that the overvoltage protector is installed as close as possible to the point where the cabling leaves the building.

Examples of Overvoltage Protection Installation

Overvoltage protection installation diagram for a device installed on the building facade and cables outside the building

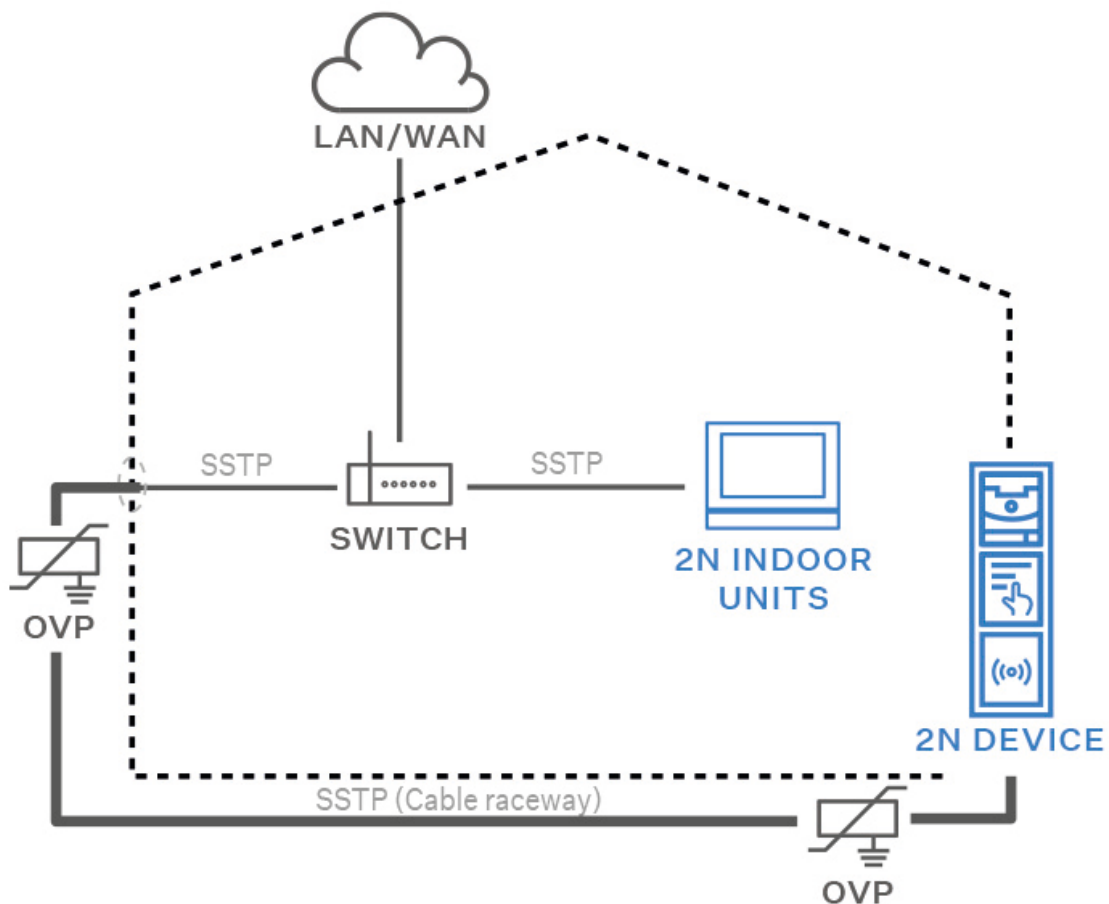

Overvoltage protection installation diagram for a device installed on the building facade and cables inside the building

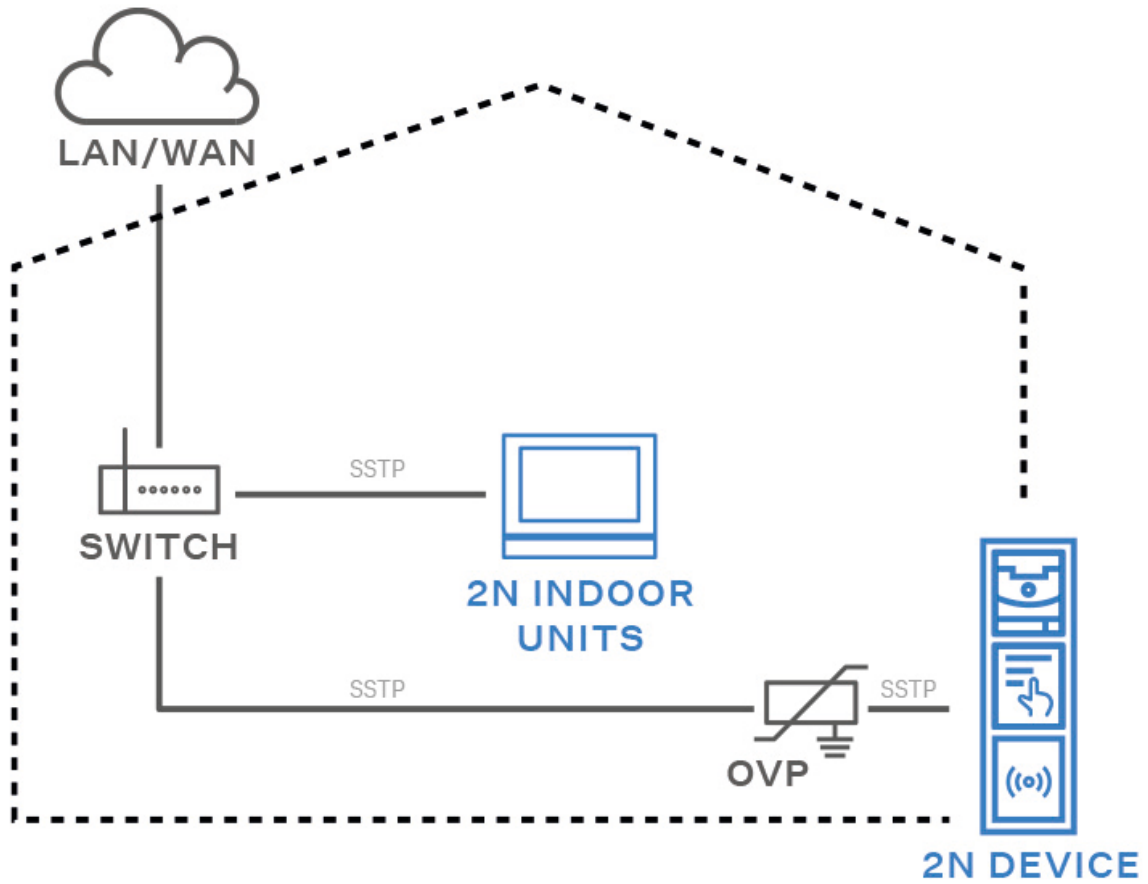

Overvoltage protection installation diagram for a device and cables installed outside the building

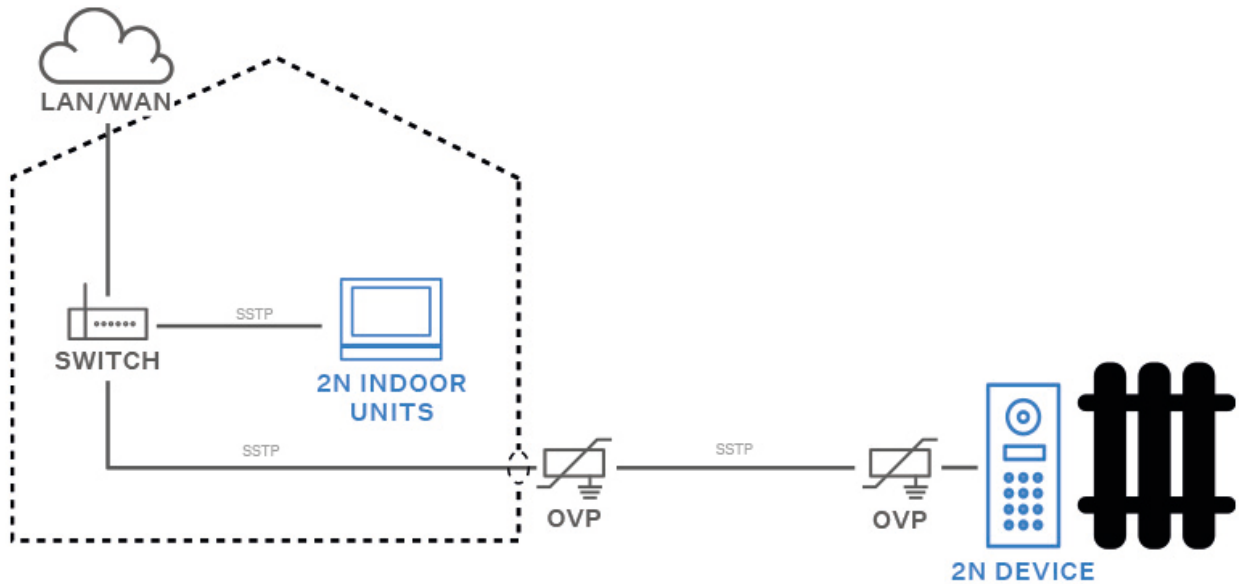

Installation Completion

Check the connection of all the wires and the RJ-45 plug insertion in the board connector.



WARNING

- Make sure that all the terminals of the unused connectors are properly tightened to avoid vibrations caused by sound.
- An incorrectly made installation may compromise the device waterproofness. Water infiltration may damage the electronic part.
- Make sure that all the holes are filled with some waterproof material – the top part, around the cables and the screws.
- Use silicone or some other sealant to seal the box against an uneven wall. Thus, you prevent water leakage and wall damping.

Installation

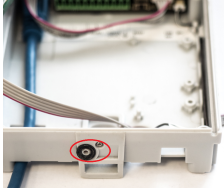

Make sure before mounting that the black sealing ring is placed properly. We recommend that the microphone is fitted with the screw included in the delivery.

Frame Attachment

Check the frame sealing before fitting the frame.

Screw the flush mounting frame in the upper and bottom parts.

Hang the surface mounting frame on the hook in the upper part and then screw it tight in the bottom part.

Most Frequent Installation Errors

Always mount the metal bolts and level the bases on an even surface **before** tightening the screws.



WARNING

Make sure that the bases are levelled properly to avoid water leakage and electronic damage.



See the side view in the drawing above for the right/wrong connection of the bases. Pay particular attention to the base connection detail. You may have a situation especially when the instructions are neglected and the screws are tightened first.

Name Tags

Name Tag Printing

1. A sheet of translucent foil is enclosed to every device. Print it using a laser printer.
2. Cut the printed foil into individual labels.



TIP

Refer to the [Support & Download Center](#) section at 2N.com for the name tag printing template.

- 1 button: 52.0 (W) x 15.2 (H) mm (dimensional tolerance: +0; -0.5 mm)
- 5-button: 57.5 (W) x 89.0 (H) mm (dimensional tolerance: +0; -0.5 mm)
- Infopanel module nametag sizes: 69.2 (W) x 86.7 (H) mm (dimensional tolerance: +0; - 0.5 mm).



CAUTION

- The area where the name tags are located is a so-called wet zone. It is because water may get onto the film during heavy rainfalls. Water in this area does not affect the function of the device and evaporates spontaneously.
- Always use waterproof foil (enclosed or other) for the nametags. Never use paper to avoid damage due to water leakage! Never use ink jet printing for the same reason!

Name Tag Insertion/Replacement

1. Remove the module frame.
2. Lift up the button door. Lift up the button door for all the buttons on the 5-button module.
3. Remove the used nametag and insert a new one.
4. Close the button door.
5. Replace the module frame.
 - a. Fit the flush mounting frame top and bottom with screws.
 - b. Hitch the surface mounting frame on the hook on top and screw it in the bottom.

Name Tag Insertion/Replacement

The advantage of **2N IP Verso** is its intuitive, simple access to name tags. There is no need to remove the front panel for replacement and so there is no risk of losing parts.

1. Loosen the name plate screw using the wrench enclosed, for example. You can open the name plate window like a door without losing the tightened screw.
2. Remove the used or blank name tag and insert a new tag.
3. Close the name plate window and tighten the screw appropriately.
4. Check the click effect of the button: if the button fails to click properly when pressed (when moved by approx. 0.5 mm), the tag is too thick or thin. Make sure that the button clicks when you press it on both ends.

Nametag Insertion/Replacement

1. Remove the module frame.
2. Lift up the button door. Lift up the button door for all the buttons on the 5-button module.
3. Remove the used nametag and insert a new one.
4. Close the button door.
5. Replace the module frame.
 - a. Fit the flush mounting frame top and bottom with screws.
 - b. Hitch the surface mounting frame on the hook on top and screw it in the bottom.



WARNING

- Make sure that all the terminals of the unused connectors are properly tightened to avoid vibrations caused by sound.
- An incorrectly made installation may compromise the device waterproofness. Water infiltration may damage the electronic part.
- Make sure that all the holes are filled with some waterproof material – the top part, around the cables and the screws.
- Use silicone or some other sealant to seal the box against an uneven wall. Thus, you prevent water leakage and wall damping.

Tactile stickers

Special tactile stickers with raised surfaces are included in the package. These stickers help people with visual impairments to recognize the basic controls of the device.

We recommend placing the sticker on the primary quick dial button. Place the sticker on the button edge and adjust the text on the label as needed to make it legible and not obscured by the sticker.



NOTE

Clean the device surface from dust and dirt before applying the sticker.

Main and Extending Modules



CAUTION

In case the firmware versions of the module to be connected and the main unit are incompatible, the module will not be detected. Therefore, update the device firmware after connecting the modules. Update firmware via the web configuration interface in System > Maintenance.



TIP

To accelerate access card reading, we recommend that the used card types are only selected in the module settings.

2N IP Verso can be interconnected with the following modules:

- [125 kHz RFID card reader \(p. 122\)](#)
- [13.56 MHz NFC RFID card reader \(p. 123\)](#)
- [Secured 13.56 MHz, NFC RFID card reader \(p. 123\)](#)
- [125 kHz, 13.56 MHz, NFC Bluetooth & RFID card reader \(p. 124\)](#)
- [125 kHz, secured 13.56 MHz, NFC Bluetooth & RFID card reader \(p. 124\)](#)
- [125kHz, 13.56MHz, NFC touch keypad & RFID card reader \(p. 125\)](#)
- [125kHz, secured 13.56MHz, NFC touch keypad & RFID card reader \(p. 125\)](#)
- [125 kHz, 13.56 MHz, NFC touch keypad & Bluetooth & RFID card reader \(p. 126\)](#)
- [125 kHz, secured 13.56 MHz, NFC touch keypad & Bluetooth & RFID card reader \(p. 127\)](#)
- [Touch keypad](#)
- [Biometric fingerprint reader \(p. 127\)](#)
- [5-button \(p. 129\)](#)
- [Keypad \(p. 129\)](#)
- [I/O module \(p. 129\)](#)
- [Wiegand module \(p. 131\)](#)
- [Security Relay \(p. 135\)](#)
- [Tamper Switch module \(p. 137\)](#)
- [OSDP module \(p. 139\)](#)
- [Induction Loop module \(p. 143\)](#)
- [Infopanel \(p. 143\)](#)
- [Blind panel module \(p. 144\)](#)

Module Interconnection

All the modules that can be connected to the device are interconnected via a bus. The bus starts on the main unit and goes over all the modules. The order of the modules on the bus is irrelevant. And it is also irrelevant which bus connector is used as the input and which is used as the output on the module.

The modules include a 220 mm long bus interconnecting cable.

The Wiegand, OSDP and I/O modules include an 80 mm long bus cable. These modules can be hidden inside one of the modules described below (Infopanel, Keypad, RFID card reader, Bluetooth) or can be

freely placed behind the device (in a mounting box, e.g.). The Tamper Switch, which is not on the bus, is interconnected with one of these modules.

It is possible to order separate bus cables of the length of 1 m, 3 m or 5 m (9155050/9155054/9155055, 01267-001/01268-001/01269-001 respectively), which are intended for remote module installations. Typically, they help install an RFID card reader on the opposite side of the wall on which the device communicator is installed. This cable may only be used once on the bus. The total length of all the bus cables used in these extended installations may not exceed 7 m.

The modules can be combined in each base as follows:

Module	External mounting into the device base (the module is visible):	Internal mounting into the device base (the module is not visible):	Internal mounting on the base bottom edge
Infopanel	✓	✗	✗
Keypad	✓	✗	✗
Touch keypad	✓	✗	✗
125 kHz RFID card reader	✓	✗	✗
13.56 MHz RFID card reader	✓	✗	✗
13.56 MHz, NFC RFID card reader	✓	✗	✗
Secured 13.56 MHz, NFC RFID card reader	✓	✗	✗
125 kHz, 13.56 MHz, NFC Bluetooth & RFID card reader	✓	✗	✗
125kHz, secured 13.56MHz, NFC Bluetooth & RFID card reader	✓	✗	✗
125kHz, 13.56MHz, NFC touch keypad & RFID card reader	✓	✗	✗

Main and Extending Modules

Module	External mounting into the device base (the module is visible):	Internal mounting into the device base (the module is not visible):	Internal mounting on the base bottom edge
125kHz, secured 13.56MHz, NFC touch keypad & RFID card reader	✓	✗	✗
Bluetooth reader	✓	✗	✗
Touch display	✓	✗	✗
Induction loop	✓	✗	✗
Fingerprint reader	✓	✗	✗
I/O	✗	✓	✗
5-Button	✓	✗	✗
OSDP	✗	✓	✗
Wiegand	✗	✓	✗
Tamper Switch	✗	✗	✓
Blind panel	✓	✗	✗

Module Power Supply

All the modules connected to the device, except for the Tamper Switch, are powered from the bus. The available bus power output depends on the power supply type.

The 571v3 main unit allows an external power supply to be used to increase the available power output for the modules connected.

Power Supply	Specification	Available power output
External supply	LPS/PS2 rated, 12 V \pm 15 % / 2 A DC (3 A for multiple modules)	24 W (36 W)
PoE	802.3af (Class 0 – 12.95 W)	12 W
Combined	External supply + PoE	30 W (42 W)

Sample Calculations

The count of modules on the bus is limited by the available power supply output. The maximum count of the modules on the bus is 30.

Main unit (571v3)	Maximum consumption [W]
At relax	2.376
Infrared illumination	3.06
LED – call	0.072
LED – ringing	0.072
LED – lock	0.072
LED – secured	0.096
Button backlight	0.072
Nametag backlight	0.072
Unit backlight	0.072
Relay 1	0.132

Main and Extending Modules

Main unit (571v3)	Maximum consumption [W]
OUT1	4.8
Audio	2.94
Total	13.84

Module	Maximum idle consumption [W]	Full load [W]
Main unit with camera	2.36	11.57
Main unit without camera	2.12	11.57
Infopanel	0.17	0.35
Keypad	0.12	1.54
Touch keypad	0.12	1.54
Fingerprint reader	0.73	1.54
125 kHz RFID card reader	0.52	1.31
13.56 MHz RFID card reader	0.44	0.82
RFID card reader 13.56 MHz, NFC	0.44	0.82
Secured 13.56 MHz NFC RFID card reader	0.44	0.82
Touch display	1.16	2.02

Main and Extending Modules

Module	Maximum idle consumption [W]	Full load [W]
Induction loop	0.18	2.99
Fingerprint scanner	0.73	1.54
I/O module	0.31 (+ 0.13 for relay activation)	0.65
5-button	0.19	0.19
OSDP	0.52	0.52
Wiegand module	0.46	0.46
Tamper Switch	0.31	0.65
Blind panel	×	×

Specimen configuration consumption computation

Module	Maximum consumption [W]	Maximum consumption [W]
Main unit with camera	2.36	11.57
13.56 MHz RFID card reader	0.44	0.82
I/O	0.31	0.65
5-button	0.19	1.16
Touch display	1.16	2.02
Tamper Switch	0.31	0.65
Wiegand	0.46	0.46

Module	Maximum consumption [W]	Maximum consumption [W]
Bluetooth reader	0.2	0.67
Total	5.43	18

It is obvious from the specimen configuration that all the modules have sufficient outputs when an external power supply is used. When a PoE supply is used, the power output is insufficient for all the modules, which results in automatic decrease in the backlight level, active output current supply, volume level and LED intensity.

Some modules need a specific power output for their specific activities: the I/O module, e.g., requires 0.13 W for relay activation (not included in the minimum consumption).

Module Specifications



CAUTION

2N IP Verso supports connection of just one Bluetooth module. If connected, multiple Bluetooth modules may result in a undesired behavior.



TIP

To accelerate access card reading, we recommend that the used card types are only selected in the module settings.

125 kHz RFID Card Reader Module

The 125 kHz RFID card reader module (91550941, 02140-001) is used for reading RFID card IDs in the 125 kHz bandwidth.

To accelerate access card reading, we recommend that the used card types are only selected in the module settings.



CAUTION

We recommend that the M-Bus and LAN cable are not crossed but carried separately through separate bushings to increase the reading distance of this reader & touch display installation.

Features

- The module contains two bus connectors for the **2N IP Verso** bus.
- These two connectors are fully interchangeable and can be used either as inputs from the main unit or outputs to other modules.
- If this module is the last one on the bus, one of the connectors remains unconnected.
- The module package includes a 220 mm long interconnecting cable.

Supported RFID cards 125 kHz:

- EM4x02
- NXP HiTag2

13.56 MHz, NFC RFID Card Reader Module

The 13.56 MHz RFID card reader (91550942, 02139-001) is used for reading RFID card IDs in the 13.56 kHz bandwidth.

To accelerate access card reading, we recommend that the used card types are only selected in the module settings.

Features

- The module contains two bus connectors for the **2N IP Verso** bus.
- These two connectors are fully interchangeable and can be used either as inputs from the main unit or outputs to other modules.
- If this module is the last one on the bus, one of the connectors remains unconnected.
- The module package includes a 220 mm long interconnecting cable.

Supported RFID cards 13.56 MHz:

- **ISO14443A** (MIFARE Classic, MIFARE Plus, MIFARE Mini, MIFARE Ultralight, MIFARE DESFire CSN only)
- **PicoPass** (HID iClass CSN, Picopass)
- **FeliCa** (Standard, Lite)
- **ST SR** (SR, SRI, SRIX)
- **My2N**
- **2N PICard**

Secured 13.56 MHz NFC RFID Card Reader Module

The 13.56 MHz RFID card reader (91550942-S/9155086, 02141-001/01712-001) is used for reading secured RFID card IDs in the 13.56 MHz bandwidth.

Features

- The module contains two bus connectors for the **2N IP Verso** bus.
- These two connectors are fully interchangeable and can be used either as inputs from the main unit or outputs to other modules.
- If this module is the last one on the bus, one of the connectors remains unconnected.
- The module package includes a 220 mm long interconnecting cable.

Supported RFID cards 13.56 MHz:

- **ISO14443A** (MIFARE Classic, MIFARE Plus, MIFARE Mini, MIFARE Ultralight, MIFARE DESFire CSN only)
- **PicoPass** (HID iClass CSN, Picopass)
- **FeliCa** (Standard, Lite)
- **ST SR** (SR, SRI, SRIX)

- **HID PAC** (HID SEOS, HID iClass SE, iClass SR, HID MIFARE DESFire with SIO, HID MIFARE Classic with SIO)
- **My2N**
- **2N PICard**

Bluetooth & 125 kHz, 13.56 MHz, NFC RFID Card Reader Module

The Bluetooth & 125 kHz and 13.56 MHz card reader module (91550945, 02778-001) is used for access control using a smartphone/tablet with **My2N** or an access card, for making user calls and/or controlling other functions.

To accelerate access card reading, we recommend that the used card types are only selected in the module settings.

Features

- NFC – for **2N My2N** for Android only, a licensed function.
- The module contains two bus connectors for the **2N IP Verso** bus.
- These two connectors are fully interchangeable and can be used either as inputs from the main unit or outputs to other modules.
- If this module is the last one on the bus, one of the connectors remains unconnected.
- The module package includes a 220 mm long interconnecting cable.

Supported RFID cards 125 kHz:

- EM4x02
- NXP HiTag2

Supported RFID cards 13.56 MHz:

- **ISO14443A** (MIFARE Classic, MIFARE Plus, MIFARE Mini, MIFARE Ultralight, MIFARE DESFire CSN only)
- **PicoPass** (HID iClass CSN, Picopass)
- **FeliCa** (Standard, Lite)
- **ST SR** (SR, SRI, SRIX)
- **My2N**
- **2N PICard**

Bluetooth & 125 kHz, secured 13.56 MHz, NFC RFID Card Reader Module

The Bluetooth & 125 kHz and secured 13.56 MHz card reader module (91550945-S, 02444-001) is used for access control using a smartphone/tablet with **2N My2N** or an access card, for making user calls and/or controlling other functions.

To accelerate access card reading, we recommend that the used card types are only selected in the module settings.

Features

- NFC – for **2N My2N** for Android only, a licensed function.
- The module contains two bus connectors for the **2N IP Verso** bus.
- These two connectors are fully interchangeable and can be used either as inputs from the main unit or outputs to other modules.
- If this module is the last one on the bus, one of the connectors remains unconnected.
- The module package includes a 220 mm long interconnecting cable.

Supported RFID cards 125 kHz:

- EM4x02

- NXP HiTag2

Supported RFID cards 13.56 MHz:

- **ISO14443A** (MIFARE Classic, MIFARE Plus, MIFARE Mini, MIFARE Ultralight, MIFARE DESFire CSN only)
- **PicoPass** (HID iClass CSN, Picopass)
- **FeliCa** (Standard, Lite)
- **ST SR** (SR, SRI, SRIX)
- **HID PAC** (HID SEOS, HID iClass SE, iClass SR, HID MIFARE DESFire with SIO, HID MIFARE Classic with SIO)
- **My2N**
- **2N PICard**

Touch Keypad & 125 kHz, 13.56 MHz, NFC RFID Card Reader Module

The touch keypad & 125 kHz and 13.56 MHz card reader module (91550946, 02779-001) is used for code/card access control, making user calls and/or controlling other functions. The touch keypad surface is very sensitive yet weatherproof at the same time.

To accelerate access card reading, we recommend that the used card types are only selected in the module settings.

Features

- NFC – for **2N My2N** for Android only, a licensed function.
- The module contains two bus connectors for the **2N IP Verso** bus.
- These two connectors are fully interchangeable and can be used either as inputs from the main unit or outputs to other modules.
- If this module is the last one on the bus, one of the connectors remains unconnected.
- The module package includes a 220 mm long interconnecting cable.

Supported RFID cards 125 kHz:

- EM4x02
- NXP HiTag2

Supported RFID cards 13.56 MHz:

- **ISO14443A** (MIFARE Classic, MIFARE Plus, MIFARE Mini, MIFARE Ultralight, MIFARE DESFire CSN only)
- **PicoPass** (HID iClass CSN, Picopass)
- **FeliCa** (Standard, Lite)
- **ST SR** (SR, SRI, SRIX)
- **My2N**
- **2N PICard**

Touch Keypad & 125 kHz, secured 13.56 MHz, NFC RFID Card Reader Module

The touch keypad with a combined 125 kHz and secured 13.56 MHz card reader (91550946-S, 02443-001) is used for code/card access control, making user calls and/or controlling other functions. The touch keypad surface is very sensitive yet weatherproof at the same time.

To accelerate access card reading, we recommend that the used card types are only selected in the module settings.

Features

- NFC – for **2N My2N** for Android only, a licensed function.

- The module contains two bus connectors for the **2N IP Verso** bus.
- These two connectors are fully interchangeable and can be used either as inputs from the main unit or outputs to other modules.
- If this module is the last one on the bus, one of the connectors remains unconnected.
- The module package includes a 220 mm long interconnecting cable.

Supported RFID cards 125 kHz:

- EM4x02
- NXP HiTag2

Supported RFID cards 13.56 MHz:

- **ISO14443A** (MIFARE Classic, MIFARE Plus, MIFARE Mini, MIFARE Ultralight, MIFARE DESFire CSN only)
- **PicoPass** (HID iClass CSN, Picopass)
- **FeliCa** (Standard, Lite)
- **ST SR** (SR, SRI, SRIX)
- **HID PAC** (HID SEOS, HID iClass SE, iClass SR, HID MIFARE DESFire with SIO, HID MIFARE Classic with SIO)
- **My2N**
- **2N PICard**

Touch Keypad & Bluetooth & 125 kHz, 13.56 MHz, NFC RFID Card Reader Module

The touch keypad with Bluetooth and a combined 125 kHz and 13.56 MHz card reader (91550947, 02781-001) is used for access control using a smartphone/tablet with **2N My2N** or code/access card, for making user calls and/or controlling other functions. The touch keypad surface is very sensitive yet weather-proof at the same time.

To accelerate access card reading, we recommend that the used card types are only selected in the module settings.

Features

- NFC – for **2N My2N** for Android only, a licensed function.
- The module contains two bus connectors for the **2N IP Verso** bus.
- These two connectors are fully interchangeable and can be used either as inputs from the main unit or outputs to other modules.
- If this module is the last one on the bus, one of the connectors remains unconnected.
- The module package includes a 220 mm long interconnecting cable.

Supported RFID cards 125 kHz:

- EM4x02
- NXP HiTag2

Supported RFID cards 13.56 MHz:

- **ISO14443A** (MIFARE Classic, MIFARE Plus, MIFARE Mini, MIFARE Ultralight, MIFARE DESFire CSN only)
- **PicoPass** (HID iClass CSN, Picopass)
- **FeliCa** (Standard, Lite)
- **ST SR** (SR, SRI, SRIX)
- **My2N**
- **2N PICard**

Touch Keypad & Bluetooth & 125 kHz, secured 13.56 MHz, NFC RFID Card Reader Module

The touch 02781-001 keypad & Bluetooth & 125 kHz and secured 13.56 MHz card reader module (91550947-S, 02782-001) is used for access control using a smartphone/tablet with **2N My2N** or code/access card, for making user calls and/or controlling other functions. The touch keypad surface is very sensitive yet weatherproof at the same time.

To accelerate access card reading, we recommend that the used card types are only selected in the module settings.

Features

- NFC – for **2N My2N** for Android only, a licensed function.
- The module contains two bus connectors for the **2N IP Verso** bus.
- These two connectors are fully interchangeable and can be used either as inputs from the main unit or outputs to other modules.
- If this module is the last one on the bus, one of the connectors remains unconnected.
- The module package includes a 220 mm long interconnecting cable.

Supported RFID cards 125 kHz:

- EM4x02
- NXP HiTag2

Supported RFID cards 13.56 MHz:

- **ISO14443A** (MIFARE Classic, MIFARE Plus, MIFARE Mini, MIFARE Ultralight, MIFARE DESFire CSN only)
- **PicoPass** (HID iClass CSN, Picopass)
- **FeliCa** (Standard, Lite)
- **ST SR** (SR, SRI, SRIX)
- **HID PAC** (HID SEOS, HID iClass SE, iClass SR, HID MIFARE DESFire with SIO, HID MIFARE Classic with SIO)
- **My2N**
- **2N PICard**



CAUTION

Press the “key” button on the card reader (without having entered any numbers) on the touch keypad & Bluetooth & RFID card reader module to start Bluetooth authentication.

Biometric Fingerprint Reader Module

The Biometric fingerprint reader module (9155045, 01276-001) is used for verification of human fingers for access control and 2N/third party equipment control.



WARNING

The fingerprint reader may not be installed on places exposed to direct sunlight. If exposed to direct sunlight, the device may report errors.

Features

- The module contains two bus connectors for the **2N IP Verso** bus.
- These two connectors are fully interchangeable and can be used either as inputs from the main unit or outputs to other modules.
- If this module is the last one on the bus, one of the connectors remains unconnected.
- The module package includes a 220 mm long interconnecting cable.

Important module properties:

- FBI PIV and Mobile ID certification – FAP20
- durable glass touch surface
- rejection of spoof fingerprints
- operating temperature range: –20 to 55 °C
- 0–90 % relative humidity, noncondensing



CAUTION

- A higher moisture may deteriorate the finger papillary line scanning. You are advised to dry your finger and the reader scanning surface for successful authentication.
- Fingerprint scanning may be more difficult for seniors whose finger papillary lines are not so distinctive (skin elasticity drops with age and a higher scanning pressure may lead to fingerprint blurring).

Touch Display Module

The Touch display (9155036, 01275-001) can be used as:

- Infopanel Module – displays the user defined image sequence
- Keypad module – virtual touch keypad
- Button module – virtual phone directory

Specification

Resolution	320 px x 214 px H x V
Slideshow resolution	214 px x 214 px
Contrast ratio	400
Brightness	350 cd/m ²
Viewing angle	80 ° from any direction
Weight	280 g

Operating temperature	-20 to +60°C
-----------------------	--------------

Resistance level	IK07
------------------	------

Connectors and Installation

Connection Options:

- The module contains two bus connectors for the **2N IP Verso** bus.
- These two connectors are fully interchangeable and can be used either as inputs from the main unit or outputs to other modules.
- If this module is the last one on the bus, one of the connectors remains unconnected.
- The module package includes a 220 mm long interconnecting cable.

5-Button Module

The 5-Button module (9155035, 01258-001) is used for selected Automation functions. Refer to 2N.com for the printing [template](#).

The buttons are backlit and can include nametags.

Features

- The module contains two bus connectors for the **2N IP Verso** bus.
- These two connectors are fully interchangeable and can be used either as inputs from the main unit or outputs to other modules.
- If this module is the last one on the bus, one of the connectors remains unconnected.
- The module package includes a 220 mm long interconnecting cable.

Specification

Nametag dimensions (W x H)	• 1 button: 52.0 (W) x 15.2 (H) mm (dimensional tolerance: +0; -0.5 mm)
	• 5-button: 57.5 (W) x 89.0 (H) mm (dimensional tolerance: +0; -0.5 mm)

Keypad Module

The Keypad module (Part No. 9155031/9155031B, 01253-001/01254-001) is used for numeric access to the system.

Features

- The module contains two bus connectors for the **2N IP Verso** bus.
- These two connectors are fully interchangeable and can be used either as inputs from the main unit or outputs to other modules.
- If this module is the last one on the bus, one of the connectors remains unconnected.
- The module package includes a 220 mm long interconnecting cable.

I/O Module

The I/O module (9155034, 01257-001) is used for extending the inputs and outputs. The module is designed for integration of sensors or other devices. The module is installed below another module, i.e. needs no separate position.

Features

- The module contains two bus connectors for the **2N IP Verso** bus.
- These two connectors are fully interchangeable and can be used either as inputs from the main unit or outputs to other modules.
- If this module is the last one on the bus, one of the connectors remains unconnected.
- The module package includes a 80 mm long interconnecting cable.
- The inputs / outputs are addressed as follows: <module_name>.<input/output_name>, e.g. "module5.relay1". Configure the module name in the Module Name parameter in **Hardware > Extending modules**.

Connectors and Installation

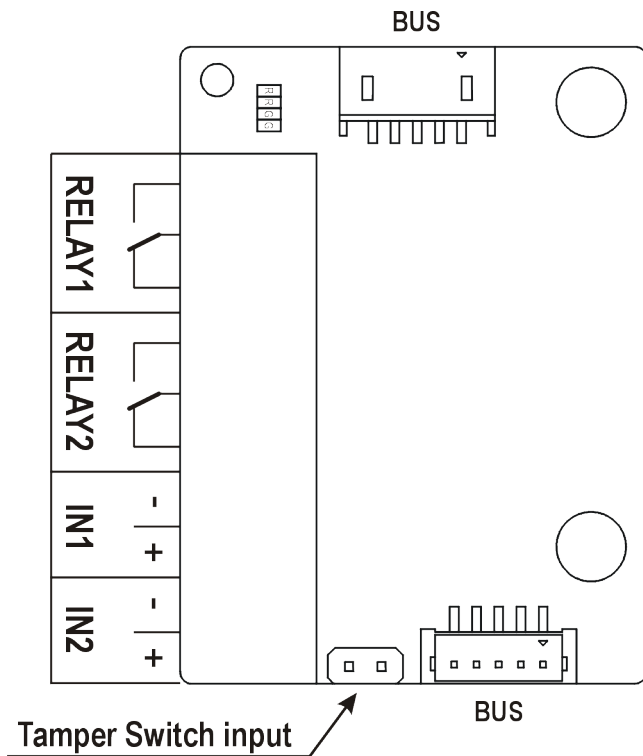

RELAY1/2 RELAY1/2 terminals with accessible 30 V / 1 A AC/DC NO/NC contact

IN1/2 IN1/2 terminals for input in passive / active mode (-30 V to +30 V DC)

- OFF = open or $U_{IN} > 1.5 \text{ V}$
- ON = short-circuited or $U_{IN} < 1.5 \text{ V}$

TAMPER Tamper Switch (9155038, 01260-001) input

The module is installed under another module, i.e. needs no separate position.

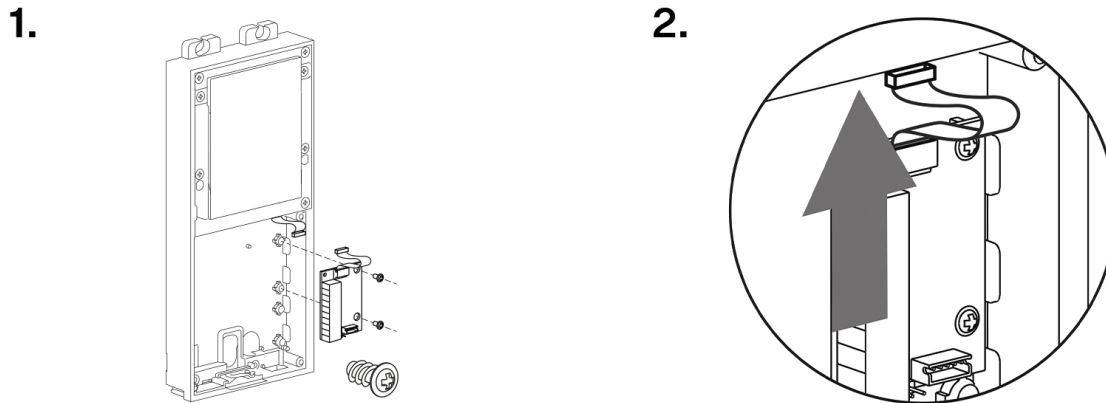

Wiegand Module

The Wiegand module (9155037, 01259-001) is used for connecting an external Wiegand device (RFID card reader, fingerprint/biometric data scanner) and/or connecting **2N IP Verso** to an external security exchange.

Features

- The module contains two bus connectors for the **2N IP Verso** bus.
- These two connectors are fully interchangeable and can be used either as inputs from the main unit or outputs to other modules.
- If this module is the last one on the bus, one of the connectors remains unconnected.
- The module package includes a 80 mm long interconnecting cable.
- Configure the module name in the Module Name parameter in **Hardware > Extending modules**.
 - LED IN is addressed as follows: <module_name>.<input1>, e.g. “module2.input1”.
 - The Tamper input is addressed as follows: <module_name>.<tamper>, e.g. “module2.tamper”.
 - LED OUT (negated) is addressed as follows: <module_name>.<output1>, e.g. “module2.output1”.

Specification

Technical Parameters of Wiegand Input

Current	5 mA
.....	
Input resistance	680 Ω
.....	
Pulse length	50 μs
.....	
Inter-pulse interval	approx. 2 ms

Connectors and Installation

All the inputs and outputs are galvanically isolated from the device with the insulation strength of 500 V DC. It is necessary to feed +U_{IN} on Wiegand W0_{OUT} from the Control Panel.

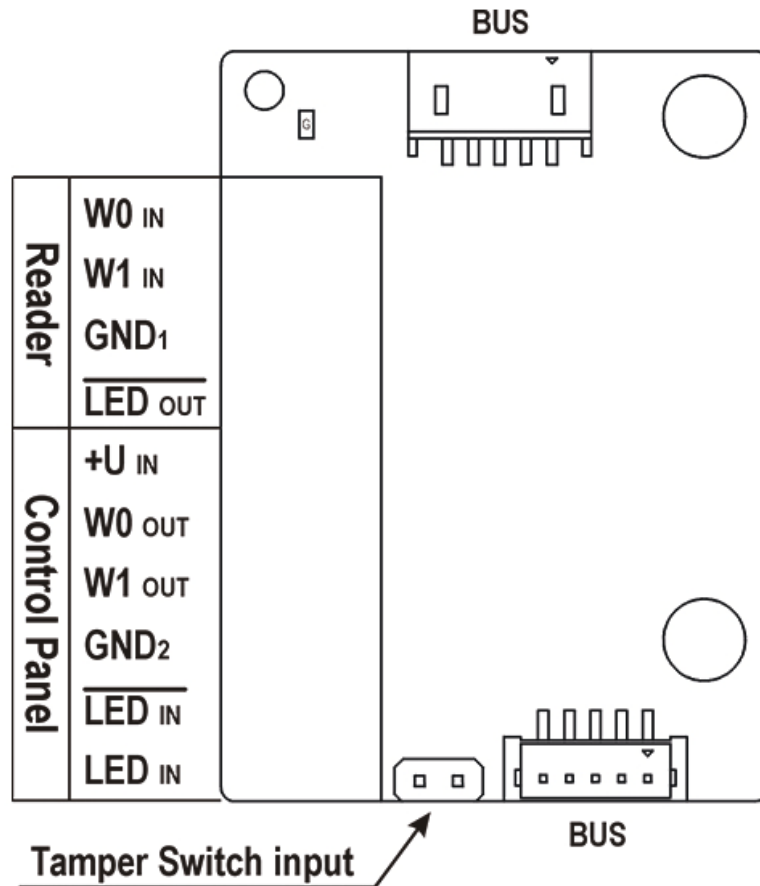

Reader helps connect an external Wiegand-supporting reader. The reader sends the device card ID.

The Control Panel is used for connection to the security PBX / access system to which the device sends the card ID information.

The module contains two BUS connectors for device bus connection. These two connectors are fully interchangeable and can be used either as inputs from the main unit or outputs to other modules.

Reader	W0 _{IN} , W1 _{IN} , GND ₁	Isolated 2-wire WIEGAND IN
	LED _{OUT}	Isolated open LED OUT switched against GND ₁ (up to 24 V / 50 mA)

Main and Extending Modules

Control Panel	+U _{IN}	+U _{IN} (5 to 15 V DC) for WIEGAND OUT power supply
	W0 _{OUT} , W1 _{OUT} , GND ₂	Isolated 2-wire WIEGAND OUT
	LED _{IN} (nega- ted)	Isolated input for open LED IN, input activated by GND ₂ connec- tion
	LED _{IN}	Isolated input for open LED IN, input activated after +U connec- tion
	G	+U _{IN} WIEGAND OUT active supply LED indicator
	TAMPER	Tamper Switch (9155038, 01260-001) input

The module is installed under another module, i.e. needs no separate position.

1.

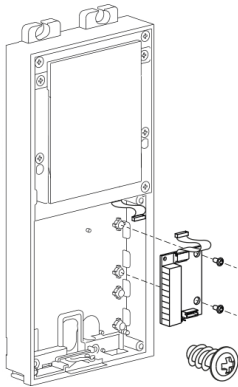

2.

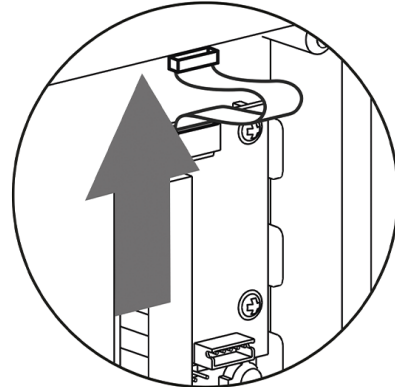

Recommended Wiegand bus wiring diagram, 2N device as a receiver.

1. **2N IP Verso**
2. External RFID Card Reader

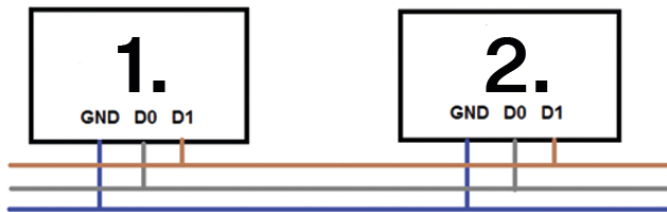

Recommended Wiegand bus wiring diagram, 2N device as a transmitter.

1. External RFID Card Reader
2. **2N IP Verso**

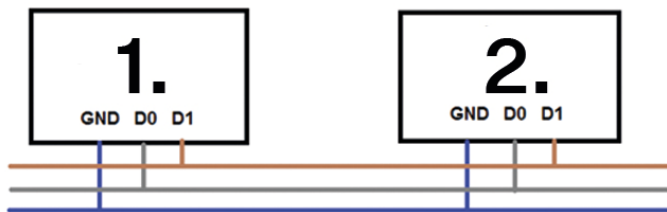

Recommended reader & OC output wiring diagram

1. **2N IP Verso**
2. External RFID Card Reader
3. 5 V power supply

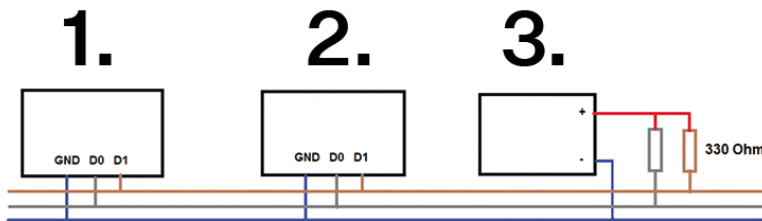

Security Relay

The Security Relay (9159010, 01386-001) is used for enhancing security between **2N IP Verso** and the connected electric lock. The Security Relay significantly enhances security of the connected electric lock by preventing unlocking due to device tampering.



TIP

FAQ: [2N Security Relay – description of the device and use with the 2N intercoms](#)

Specification

Passive switch NO/NC contact, up to 30 V / 1 A AC/DC

Switched out-
put

- Where the Security Relay is fed from the device, 8 to 12 V DC is available on the output depending on the power supply, 400 mA DC.
 - PoE: 10 V
 - adapter: source voltage of minus 2 V
- Where the Security Relay is fed from an external power supply, 12 V / 700 mA DC is available on the output.

Dimensions 66.5 × 32.5 × 20.5 mm

Weight 24 g

Connectors and Installation

The Security Relay is installed between the device (outside the secured area) and the electric lock (inside the secured area). The Security Relay includes a relay that can only be activated if a valid access card/code is detected on the unit.

The Security Relay is installed on a two-wire cable between the device and the electric lock inside the area to be secured (typically behind the door). The Security Relay is powered and controlled via this two-wire cable and can thus be added to an existing installation. Thanks to its compact dimensions, the device can be installed into a standard mounting box.

The Security Relay is designed with holes for surface anchoring. It is recommended that a screw of the diameter of 3 mm with a lens head of the diameter of 6 mm is used. Using a countersunk head may cause irreversible damage to the plastic cover!

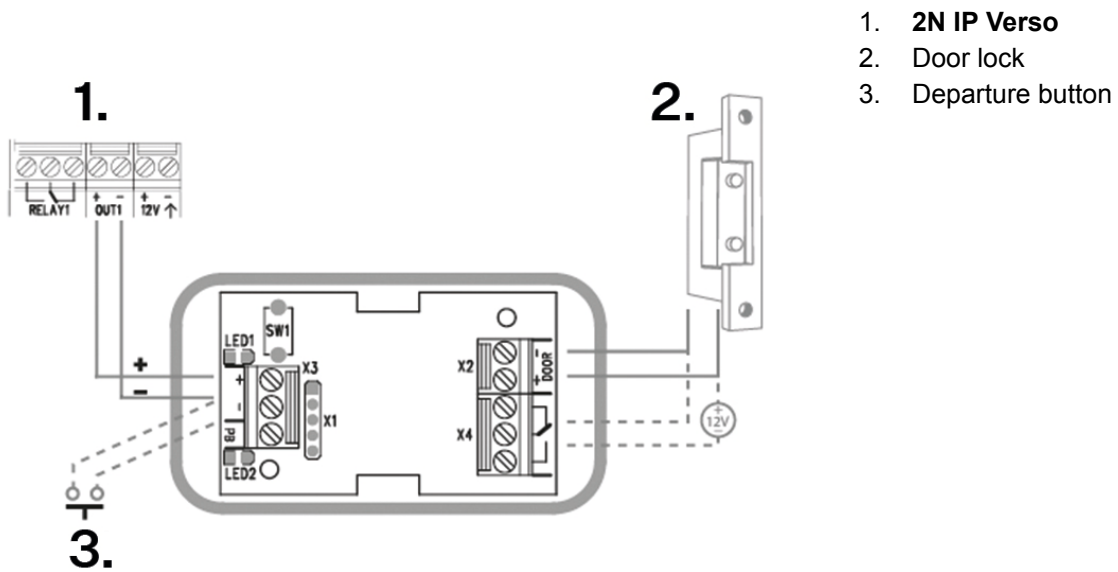

Connect the Security Relay to the access unit as follows:

- To the Active output

Connect the electric lock to the Security Relay as follows:

- to the switched output
- to the passive output in series with the external power supply

The Security Relay also supports the Departure button connected to the 'PB' and '- 2N IP intercom' terminals. Once the Departure button is pressed, the output is activated for 5 seconds.

<https://www.youtube.com/embed/ardukvQzw5A>

Status Signaling

Green LED	Red LED	State
flashing	off	Operational mode
on	off	Activated output
flashing	flashing	Programming mode – waiting for initialization
on	flashing	Error – wrong code

Configuration

1. Connect the Security Relay to the properly set Security output of the device. Refer to the Configuration Manual for details. Make sure that one LED at least is on or flashing.
2. Press and hold the Relay RESET button for 5 seconds to switch the device in the programming mode (red and green LEDs flashing).
3. Activate the output switch using the keypad, telephone, etc. The first code sent from the device will be stored in the memory and considered valid. After code initialization, the Security Relay will pass into the operational mode (green LED flashing).



CAUTION

Having reset the factory defaults on a device with firmware 2.18 or higher, remember to reprogram Security Relay using the instructions above.

Tamper Switch Module

The Tamper Switch module (9155038, 01260-001) of **2N IP Verso** is used for securing the system against unauthorized tampering.



CAUTION

Remember to purchase [I/O Module \(p. 129\)](#), [OSDP Module \(p. 139\)](#) or [Wiegand Module \(p. 131\)](#) along with the Tamper Switch.

Features

The module contains two switches that open whenever the front frame is removed:

- One switch leads directly to the terminal board and is designed for connection to an external security exchange (32 V DC / 50 mA max).
- The other switch, in combination with the [I/O module \(p. 129\)](#), [OSDP module \(p. 139\)](#) or [Wiegand module \(p. 131\)](#), can be used for alarm triggering via the Automation interface in the **2N IP Verso** configuration.

Connectors and Installation

This module is not connected to the bus.



Jumpers are used for interconnecting the Tamper Switch pins with the I/O / OSDP / Wiegand module.

1.

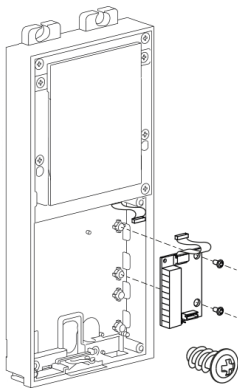

2.

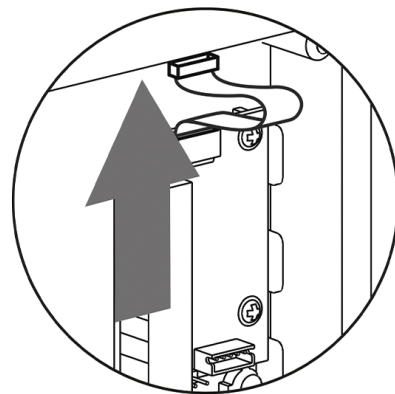

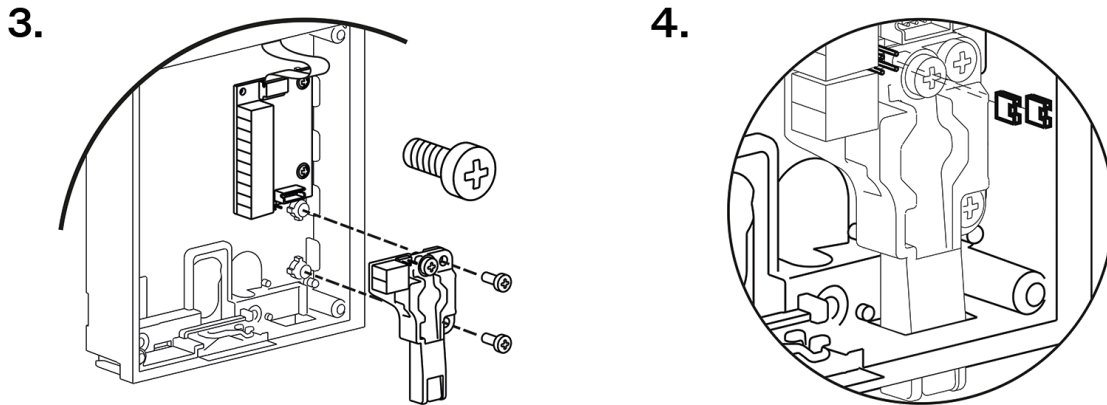

OSDP Module

The OSDP module (91550371, 02577-001) of **2N IP Verso** provides OSDP communication between a connected OSDP device (control panel, door controller) and the device. The OSDP module provides secure sending of such access data as the access card ID or PIN code.

Features

- The module contains two bus connectors for the **2N IP Verso** bus.
- These two connectors are fully interchangeable and can be used either as inputs from the main unit or outputs to other modules.
- If this module is the last one on the bus, one of the connectors remains unconnected.
- The module package includes a 80 mm long interconnecting cable.

The module also includes:

- Isolated OSDP bus
- Power and pairing mode signaling LED
- Tamper Switch (9155038, 01260-001) input

Connectors and Installation

All the inputs and outputs are galvanically isolated from **2N IP Verso** with the insulation strength of 1500 V DC.

2. Connect the OSDP device as instructed (A to B or B to A) keeping the correct order to avoid malfunction.



CAUTION

- Mounting jumpers JP2 and JP3 results in a connection of strong pull-up/pull-down resistors (560 ohms) to the RS-485 bus. These jumpers must be mounted/unmounted together, i.e. one jumper cannot be mounted alone. Strong pull-up and pull-down resistors can be connected only and exclusively to one arbitrary device on the OSDP bus.
- Mounting JP4 results in a connection of the terminating 120 ohm resistor between wires A and B of the OSDP bus. The terminating resistors may be connected exclusively on the first and last modules on the OSDP bus. We recommend the connection of these resistors on the first and last modules.

1.

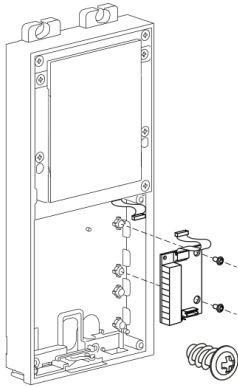

2.

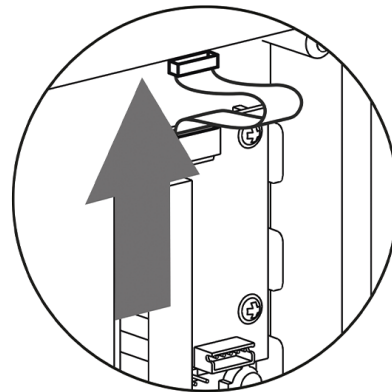

Connection Recommendations

Wiring diagram for two-wire connection

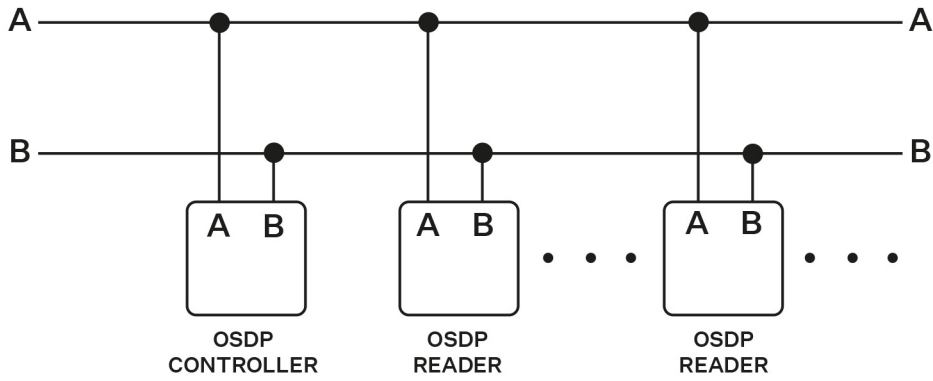

Wiring diagram for three-wire connection

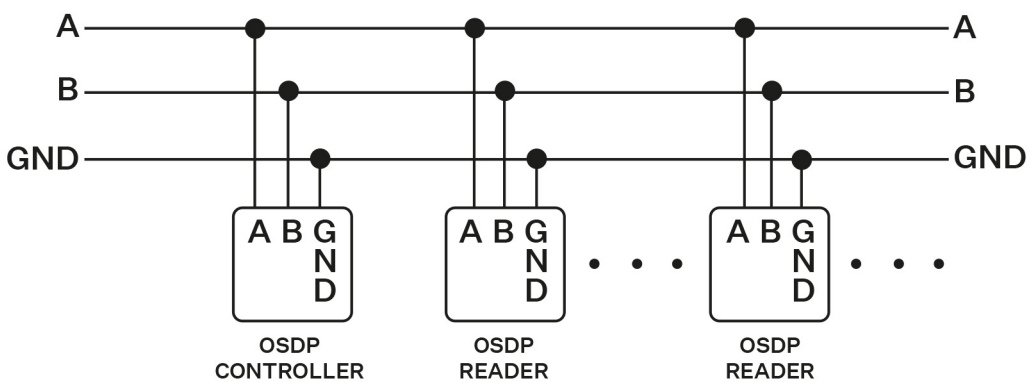

Configuration

Having logged in to the device web interface, use the **Hardware > Extending modules** menu to set the following:

1. Name the module for user identification (optional).
2. Choose a group for access data resending, making sure that the settings are identical with those of the access readers from which the data are to be resent (card ID, PIN).
3. The setting of the codes to be transmitted is optional.
4. Enter the OSDP address between 0 and 126 to set the OSDP module address on the OSDP line.
5. Set the communication rate in accordance with the requirements of the device to be connected.
6. Enter your own encryption key into **2N IP Verso** and the opponent's device to ensure encrypted communication.
7. Enable forced encryption just for encrypted communication.

Any unencrypted communication from the OSDP device will be rejected if forced encryption is enabled.

If the OSDP device enables remote encryption key setting on a peripheral, you can use the installation mode. Once the encryption key is received, the common mode is automatically switched on. The installation mode is signaled by a LED fast flashing on the OSDP module.

Induction Loop Module

The Induction Loop module (9155041, 01263-001) on **2N IP Verso** is used for transmitting audio signals via the magnetic field directly into the hearing aids.

Features

- The module contains two bus connectors for the **2N IP Verso** bus.
- These two connectors are fully interchangeable and can be used either as inputs from the main unit or outputs to other modules.
- If this module is the last one on the bus, one of the connectors remains unconnected.
- The module package includes a 220 mm long interconnecting cable.

Specification

Used mode	T
Maximum power	2 W
Frequency range	100 Hz – 5 kHz / \pm 3 dB
Antenna output short circuit resistance	without restriction

Infopanel Module

The Infopanel module (9155030, 0159-7891) is used for inserting and backlighting printed information. It helps place a company logo or opening hours, e.g., to the device. The Infopanel is backlit, the backlight is software controlled. Refer to 2N.com for the printing template.

Features

- The module contains two bus connectors for the **2N IP Verso** bus.
- These two connectors are fully interchangeable and can be used either as inputs from the main unit or outputs to other modules.

Main and Extending Modules

- If this module is the last one on the bus, one of the connectors remains unconnected.
- The module package includes a 220 mm long interconnecting cable.

Specification

Nametag dimensions (W x H) 69.2 x 86.7 mm (tolerance: +0; -0.5 mm)

Blind Panel Module

The Blind panel module (Part Nos. 9155039, 01261-001) is used for occupying an empty position.

Brief Guidelines

- [Device Configuration Interface Access \(p. 145\)](#)
- [Configuration via Hardware](#)
- [IP Address Retrieval \(p. 148\)](#)
- [Dynamic/Static IP Address Switching](#)
- [Firmware Update \(p. 151\)](#)
- [Device Restart \(p. 151\)](#)
- [Factory Default Reset \(p. 153\)](#)
- [Call Connection](#)

Device Configuration Interface Access

2N IP Verso is configured via a web configuration interface. You have to know the device IP address or the device domain name. Make sure that the device is connected to the local IP network and powered.

Refer to the Configuration [Manual for 2N IP Intercoms](#) for the device configuration details.

Domain Name

Enter the device domain name as “hostname.local” to connect to the device. The hostname of a new device consists of the device name and serial number. Enter the serial number into the domain name without dashes. Change the hostname anytime in **System > Network**.

Default domain name 2N IP Verso: 2NIPVerso-{serial number without dashes}.local (e.g.: “2NIPVerso-0000000001.local”)

Login based on a domain name is advantageous if the dynamic IP address is used. While the dynamic IP address changes, the domain name remains the same. It is possible to generate certificates signed by a trusted certification authority for the domain name.

IP address

To retrieve the device IP address, take the following steps, see :

- Use the freely accessible **2N Network Scanner**.
- Use hardware (RESET button).
- Use the Speed Dial button.

Web Configuration Interface Login

1. Fill in the **2N IP Verso** address or domain name into the internet browser.

The login screen is now displayed.

Should the login screen fail to appear, make sure that you have typed the correct IP address, port or domain name. The login screen also does not appear when the administration web server is off. If you do not have a certificate generated for the IP address / domain name, an invalid security certificate warning may be displayed. In this case, you have to confirm that you want to go to the web configuration interface.

2. Enter the login data.

The default login data are:

Username: **Admin**

Password: **2n**

It is necessary to change the password immediately upon the first login.

After login using the default password, the access to the web configuration interface functions is limited.

**TIP**

It is recommended that a password is used that is difficult to break. It is not recommended that names, places or things, especially those closely related to the user, are used in the password.

For increased password security, it is recommended that:

- the random password generator is used,
- the password length is 12 characters at least,
- various characters from different character sets are combined (small/capital letters, digits, special characters, etc.).

Configuration via Hardware

Where software configuration is unavailable, make basic settings using the RESET button (refer to [Device Connectors \(p. 105\)](#)).

The RESET button helps you reset the factory default values, restart the device, retrieve the device IP address and switch the IP address static/dynamic mode.

Device Restart

Press the button shortly (< 1 s) to restart the system without changing configuration.

IP Address Retrieval Using Hardware

Follow the instructions below to retrieve the current IP address:

1. Press the button RESET and keep it pressed.
 - a. Wait until the red and green LEDs go on simultaneously on the device and the acoustic signal can be heard  (approx. 15–35 s).
2. Release the RESET button.
3. The device announces the current IP address via the speaker automatically.

**NOTE**

The delay after pressing RESET till the first light and sound signaling is set to 15–35 s depending on the device model used.

Dynamic/Static IP Address Switching

Follow the instructions below to switch on the Static IP address mode (DHCP OFF):

1. Press the button RESET and keep it pressed.
 - a. Wait until the red and green LEDs go on simultaneously on the device and the acoustic signal can be heard 🗣️ (approx. 15–35 s).
 - b. Wait until the red LED goes off and the acoustic signal can be heard 🗣️ (approx. for another 3 s).
2. Release the RESET button.

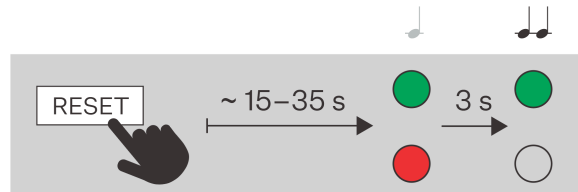

NOTE

The following network parameters will be set after restart:

- IP address: 192.168.1.100
- Network mask: 255.255.255.0
- Default gateway: 192.168.1.1

Dynamic IP Address Setting

Follow the instructions below to switch on the Static IP address mode (DCHP ON):

1. Press the button RESET and keep it pressed.
 - a. Wait until the red and green LEDs go on simultaneously on the device and the acoustic signal can be heard 🗣️ (approx. 15–35 s).
 - b. Wait until the red LED goes off and the acoustic signal can be heard 🗣️ (approx. for another 3 s).
 - c. Wait until the green LED goes off and the red LED goes on again and the acoustic signal can be heard 🗣️ (approx. for another 3 s).
2. Release the RESET button.

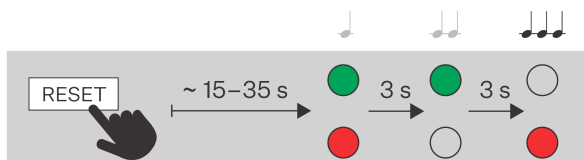

Factory Default Reset

1. Press the button RESET and keep it pressed.
 - a. Wait until the red and green LEDs go on simultaneously on the device and the acoustic signal can be heard 🗣️ (approx. 15–35 s).
 - b. Wait until the red LED goes off and the acoustic signal can be heard 🗣️ (approx. for another 3 s).
 - c. Wait until the green LED goes off and the red LED goes on again and the acoustic signal can be heard 🗣️🗣️ (approx. for another 3 s).
 - d. Wait until the red LED goes off and the acoustic signal can be heard 🗣️🗣️🗣️ (approx. for another 3 s).
2. Release the RESET button.

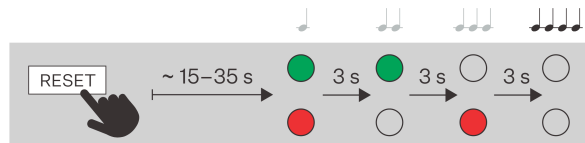

IP Address Retrieval

To retrieve the device IP address, take the following steps:

- Use the freely accessible **2N Network Scanner**.
- Use hardware (RESET button).
- Use the Speed Dial button.

IP Address Retrieval Using 2N Network Scanner

The application helps you find the IP addresses of all the 2N devices in the LAN. Download **2N Network Scanner** from the [2N.com](https://www.2n.com) website. Make sure that Microsoft .NET Framework 2.0 is installed for successful app installation.

1. Run the **2N Network Scanner** installer.
2. The Installation Wizard will help you with the installation.

- Having installed **2N Network Scanner**, start the application using the Microsoft Windows Start menu. Once started, the application begins to automatically search the LAN for all the 2N devices which have been DHCP/statically assigned IP addresses. These devices are then shown in a table.

The screenshot shows the '2N® Network Scanner (version 3.0.4)' application window. It features a menu bar with 'File' and 'Help', and a 'Filter' input field. Below is a table with four columns: 'IP Address', 'Serial Number', 'Display Name', and 'Version'. The table contains 15 rows of data. The row with IP address 10.0.24.105 is highlighted in blue, indicating it is the selected device. The status bar at the bottom indicates 'Count: 15'.

IP Address	Serial Number	Display Name	Version
10.0.24.69	54-1921-5022	2N IP Verso Mobile Team	2.29.0.38.6
10.0.24.73	52-1953-0073	2N Indoor Touch 2.0	4.0.0
10.0.24.74	54-0956-0004	2N Indoor Touch	3.4.0.1.0
10.0.24.75	52-1953-0064	2N Indoor Touch 2.0	999.4.3.0 (eng.378...
10.0.24.78	52-1953-0079	2N Indoor Touch 2.0	999.4.4.0 (eng.502...
10.0.24.79	52-2339-0077	2N Indoor Compact	2.30.0.39.0
10.0.24.87	52-2101-0046	2N Indoor Touch 2.0	4.3.0 (rc.4.3.x)
10.0.24.102	52-1953-0098	2N Indoor Touch 2.0	999.4.4.0 (eng.496...
10.0.24.105	52-2656-0067	2N Indoor View	2.29.0.38.6
10.0.24.108	52-2700-0559	2N Indoor Touch 2.0	999.4.4.0 (eng.494...
10.0.24.116	52-2667-0295	2N Indoor Touch 2.0	4.2.2 (release.4.2.2)
10.0.24.123	99-8888-0035	2N Indoor Touch 2.0	999.4.1.7 (eng.root...

- Select the device to be configured and right-click it. Select *Browse...* to open the device administration web interface login box for configuration.



CAUTION

If the found device is grey highlighted, its IP address cannot be configured using this application. In that case, click Refresh to find the device again and check whether multicast is enabled in your network.



TIP

- Double click the selected row in the **2N Network Scanner** list to access the device web interface easily.
- To change the device IP address, select *Config* and enter the required static IP address or activate DHCP.

The default login data are:

Username: **Admin**

Password: **2n**

It is necessary to change the password immediately upon the first login.

**TIP**

It is recommended that a password is used that is difficult to break. It is not recommended that names, places or things, especially those closely related to the user, are used in the password.

For increased password security, it is recommended that:

- the random password generator is used,
- the password length is 12 characters at least,
- various characters from different character sets are combined (small/capital letters, digits, special characters, etc.).

IP Address Retrieval Using Hardware

Follow the instructions below to retrieve the current IP address:

1. Press the button RESET and keep it pressed.
 - a. Wait until the red and green LEDs go on simultaneously on the device and the acoustic signal can be heard (approx. 15–35 s).
2. Release the RESET button.
3. The device announces the current IP address via the speaker automatically.

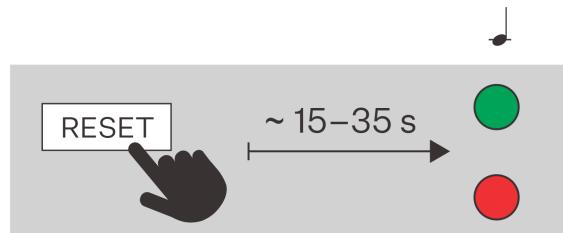
**NOTE**

The delay after pressing RESET till the first light and sound signaling is set to 15–35 s depending on the device model used.

IP Address Retrieval Using Speed Dial Button

Take the following steps to retrieve the **2N IP Verso** IP address:

1. Connect the device to the power supply (if connected, disconnect and reconnect it).
2. Wait for the second sound signal.
3. Press the Quick dial button 5 times on the main unit.
4. The device reads its IP address.

**NOTE**

- If the address is 0.0.0.0, it means that the device has not obtained the IP address from the DHCP server.
- Press the button sequence within 30 seconds after the sound signal for security reasons. Up to 2 s intervals are allowed between the presses.

Dynamic/Static IP Address Switching and Network Parameter Reset

Take the following steps to reset the network settings and switch the static IP address (DHCP OFF) / dynamic IP address (DHCP OFF) mode in the device network configuration:

1. Connect the device to the power supply (if connected, disconnect and reconnect it).
2. Wait for the first sound signal.
3. Press the Quick dial button 15 times on the main unit.

Resetting the network parameters and switching DHCP are indicated by a sound signal. In devices with FW version 2.33 and lower, wait until the device restarts automatically. Upon restart, the static IP address mode will be switched to the dynamic IP address mode and vice versa. By doing this, you reset all the System > Network parameters to the default values. This is useful when it is impossible to connect to the device due to erroneous VPN configuration, for example.

**NOTE**

After the static address mode is switched on, the basic network parameters are reset to the following default values:

- IP address: 192.168.1.100
- Network mask: 255.255.255.0
- Default gateway: 192.168.1.1

Firmware Update

We recommend that the firmware is also updated during the **2N IP Verso** installation. Refer to [2N.com](https://www.2n.com) for the latest FW version.

Update firmware via the web configuration interface in System > Maintenance, refer to the device Configuration Manual.

Once the firmware is uploaded successfully, the device is restarted automatically.

**TIP**

You can make bulk updates for multiple devices via **2N Access Commander**.

Device Restart

To restart the device choose one of the following options:

- using the RESET button,
- using disconnection from the power supply,
- via the web configuration interface.

**NOTE**

The device restart does not result in any change in the configuration settings.

Restart Using RESET Button



Press the button shortly (< 1 s) to restart the system without changing configuration.

Restart Using Web Configuration Interface

You can restart the device via the web configuration interface. Refer to [Web Configuration Interface Login \(p. 145\)](#) for login details. Restart the device in System > Maintenance > System using [Restart device](#).

Dynamic/Static IP Address Switching

Follow the instructions below to switch on the Static IP address mode (DHCP OFF):

1. Press the button RESET and keep it pressed.
 - a. Wait until the red and green LEDs go on simultaneously on the device and the acoustic signal can be heard  (approx. 15–35 s).
 - b. Wait until the red LED goes off and the acoustic signal can be heard  (approx. for another 3 s).
2. Release the RESET button.

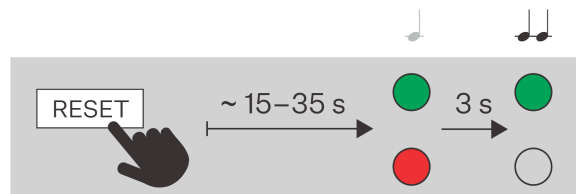
**NOTE**

The following network parameters will be set after restart:

- IP address: 192.168.1.100
- Network mask: 255.255.255.0
- Default gateway: 192.168.1.1

Dynamic IP Address Setting

Follow the instructions below to switch on the Static IP address mode (DCHP ON):

1. Press the button RESET and keep it pressed.
 - a. Wait until the red and green LEDs go on simultaneously on the device and the acoustic signal can be heard 🎵 (approx. 15–35 s).
 - b. Wait until the red LED goes off and the acoustic signal can be heard 🎵 (approx. for another 3 s).
 - c. Wait until the green LED goes off and the red LED goes on again and the acoustic signal can be heard 🎵 (approx. for another 3 s).
2. Release the RESET button.

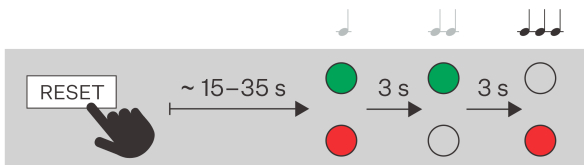

Factory Default Reset

Reset the device factory default values via software in System > Maintenance > Default reset.

Follow the instructions below **2N IP Verso** to reset the factory default values via hardware:

Factory Default Reset

1. Press the button RESET and keep it pressed.
 - a. Wait until the red and green LEDs go on simultaneously on the device and the acoustic signal can be heard 🎵 (approx. 15–35 s).
 - b. Wait until the red LED goes off and the acoustic signal can be heard 🎵 (approx. for another 3 s).
 - c. Wait until the green LED goes off and the red LED goes on again and the acoustic signal can be heard 🎵 (approx. for another 3 s).
 - d. Wait until the red LED goes off and the acoustic signal can be heard 🎵 (approx. for another 3 s).
2. Release the RESET button.

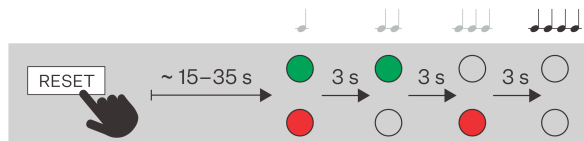

CAUTION

In case the factory default values are reset on the device with a firmware version 2.18 or higher, it is necessary to reprogram the 2N Security Relay using the instructions given in [Security Relay \(p. 135\)](#).

Device Control

2N IP Verso is an intercom allowing you to:

- call other devices
 - use quick dial buttons
 - dial phone book position
 - dial phone number
- receive and reject incoming calls
- activate switch (e.g. door opening, lift control, etc.)

The device works as an authorization intermediary, which authenticates the user access rights and, if the user access is valid, activates the switch. The door lock, lifts etc. can be controlled by the switch.

The device control depends on the product version:

- using RFID cards and chips – by tapping a card/chip on the device,
- using the **2N My2N** application – by pressing the device touchscreen in the vicinity of a mobile device with **2N My2N** logged in,
- using NFC,
- using biometric data (fingerprint)
- by entering a numeric access code via a keypad , touch keypad or in the 2N My2N application
- control the device using a touch display
- activate/deactivate users or profiles using the **2N My2N** mobile application

Speed Dial Buttons

By pressing the speed dial button on the main unit, you can make a quick call to the assigned position in the phone book, see the Intercom Configuration > Calling > Dialing chapter in the Configuration Manual.

Use extending modules to extend the number of quick dial buttons to up to 146.

Call setup is signaled by a long intermittent tone or otherwise as configured in the PBX connected.

Pressing the same button repeatedly during or while making a call can be assigned the function of hanging up or hanging up simultaneously with a call to the next phone number of the called party. Alternatively, pressing the same button repeatedly may have no function, see **Intercom Configuration > Calling > General Settings** in the Configuration Manual.

For keypad equipped models, you can also hang up the call at any time by pressing  if enabled so by the Button function during an outgoing call parameter, see **Intercom Configuration > Calling > General Settings** in the Configuration Manual.

Calling to Phone Book Position



The Phonebook **2N IP Verso** can contain up to 10 000 pre-programmed positions. Depending on the number of speed dial buttons actually installed, you can call a given number of positions in the phone book. The remaining positions can be retrieved via the numeric keypad if the **Speed dial using digits** is enabled in configuration.

1. Enter the position number using your numeric keypad (05, 15, 200 e.g. – two digits at least and four digits at most) and press  for confirmation.



- For keypad equipped models, you can also hang up the call at any time by pressing  if enabled so by the Button function during an outgoing call parameter, see **Intercom Configuration > Calling > General Settings** in the Configuration Manual.

Calling to User-Defined Phone Number

If the **Phone Function Enable** parameter is set, you can use the numeric keypad to call a user-entered phone number.

- Press the  button.
- You will hear a continuous tone from the speaker.
- Enter the telephone number using the numerical keypad and repress  for confirmation.
- For keypad equipped models, you can also hang up the call at any time by pressing  if enabled so by the Button function during an outgoing call parameter, see **Intercom Configuration > Calling > General Settings** in the Configuration Manual.

Incoming Call Answering/Rejecting

If the automatic incoming call answering function is turned off, an incoming call is signaled by a loud ringing tone. Push the  button to answer the call and the  button to reject the call.

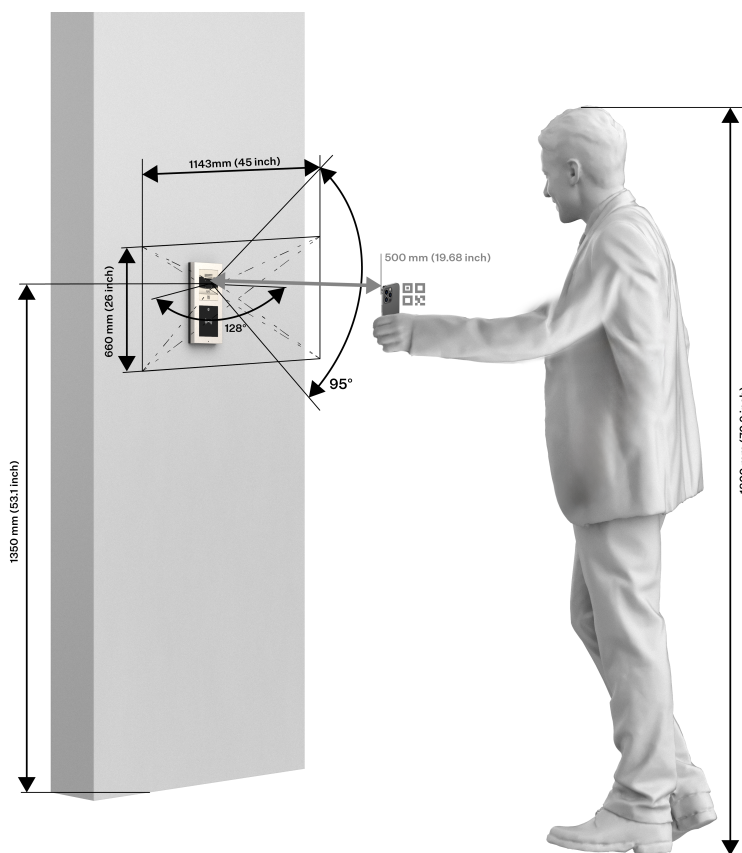

Switch-Off Using QR Code

The visualization below shows the (range of the) field of view and optimum installation height for the device camera. It is recommended that the QR code is placed 50 cm in front of the camera for optimum reading.



Door Opening (Switch Activation) by Code

2N IP Verso is equipped with a door unlocking switch. Enter the valid code (refer to Subs. [Switches](#) of the Configuration Manual for IP Intercoms) using the numeric keypad to activate this switch.

1. Enter the switch activating numeric code using the numeric keypad and press the  button for confirmation.
2. A valid code is notified visually and by a continuous switch activation tone or a predefined unlocking user sound. An invalid code or interruption longer than as defined in **Timeout for Entering Numbers** is signaled acoustically  or using a user sound.

Door Opening (Switch Activation) by Biometric Reader

The Fingerprint reader is used for verification of human fingers for access control and intercom control. Refer to the Directory > [Users](#) subsection in the Configuration Manual for IP Intercoms for how to load a fingerprint into a user profile.

1. Apply your finger to the reader scanning area.
2. Reader authentication light signalling indicates the status of:
 - **Green** – the fingerprint has been recognised successfully.
 - **Green flashes to red** – the fingerprint has been recognised but access is denied. Check the user time profile setting state and multiple authentication setting. Access can also be blocked by a previous tamper switch blocking.
 - **Red** – the fingerprint has not been recognised.



CAUTION

A higher moisture may deteriorate the finger papillary line scanning. You are advised to dry your finger and the reader scanning surface for successful authentication.

LED pictograms

The following photo shows the location of the elements on the front of the device.

HW version 4 and higher

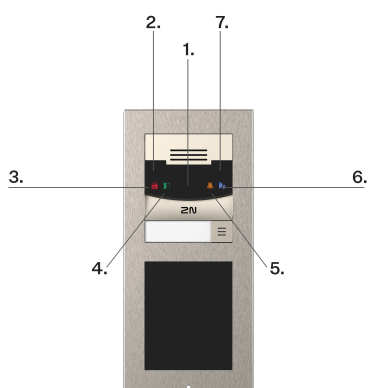

HW version 3 and lower

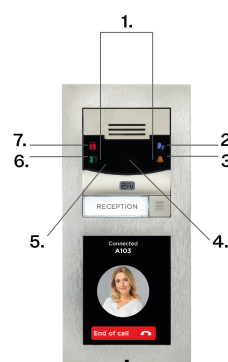

HW version 4 and higher	HW version 3 and lower
1. Camera	1. IR Illumination
2. Light sensor	2. Call
3. Secured	3. Ringing
4. Enabled entry	4. Camera
5. Ringing	5. Light sensor
6. Call	6. Enabled entry
7. IR Illumination	7. Secured

Colour Signalling

Devices with a display or LED pictograms display different statuses in color.

Status Signaling

Color	State	Description
Red	Active Access Blocking	Occurs if access is not allowed (it is not possible to activate the door switch) or occurs again after a specified period of time after the door switch is deactivated.
	Switch Locking	Applies to a switch that is configured as a door switch.
	Secured Status	Display of this status is only allowed on the device main unit if signaling is available.
Blue	Entering Access Code	Occurs when the user is entering the code and signals the possibility to confirm the code.
Green	Access Enable	Occurs when the access lock is deactivated and signals door opening or switch activation.

Maintenance - Cleaning

2N IP Verso contains no environmentally harmful components. Dispose of the device in accordance with the applicable legal regulations.

If used frequently, the device surface gets dirty. Use a piece of soft cloth moistened with clean water to clean the device. Use appropriate cleaning agents suitable for glasses, optical devices, screens, etc. We recommend that IT cleaning wipes are used.



CAUTION

Use the product for the purposes it was designed and manufactured for, in compliance herewith. The manufacturer reserves the right to modify the product in order to improve its qualities.

If used frequently, the device surface gets dirty. Use a piece of soft cloth moistened with clean water to clean the device. Use appropriate cleaning agents suitable for glasses, optical devices, screens, etc. We recommend that IT cleaning wipes are used.

- Do not use aggressive and alcohol/peroxide based detergents.
- For cleaning the glass lens, use suitable cleaning agents designed for cleaning glasses, optics, screens, etc.



TIP

To disinfect the surface of the device against bacteria and viruses (Anti-Covid) and maintain the hygienic conditions of critical surfaces and touch points, we recommend that you use the Zoono – Microbe Shield Surface Sanitiser spray.

Troubleshooting

Refer to <https://www.2n.com/faqs> for the most frequently solved problems.

Technical Parameters

Power supply types in compliance with LPS/PS2:

PoE IEEE PoE 802.3af (Class 0, max. 12,95 W) (Class 0, max. 12.95 W)

External supply LPS/PS2 rated, 12 V \pm 15 % / 2 A DC (3 A for multiple modules)

Signaling protocol

SIP UDP, TCP, TLS

Buttons

Button design Transparent, white backlit buttons with easily replaceable nametags

Button count 1 to multiples of 5 (depending on the configuration)

Button extenders Up to 29 modules (limited by power supply)

Numeric Keypad Optional

Audio

Microphone Integrated

Amplifier 2 W (class D)

Speaker 2 W / 8 Ω

Technical Parameters

Audio

Sound pressure level (SPL max) 78 dB (for 1 kHz, distance 1 m)

LINE OUT 1 VRMS / 600 Ω

Volume Control Adjustable with automatic adaptive mode

Full duplex Yes (AEC)

Audio power output 0.89

Audio stream

Protocols

- RTP
- SRTP

Codecs and Used Bandwidth

- G.711 (PCMA, PCMU) – 64 kbps (with 85.6 kbps headers)
- G.729 – 16 kbps (with 29.6 kbps headers)
- G.722 – 64 (with 85.6 kbps headers)
- L16/16kHz – 256 kbps (with 277.6 kbps headers)

Camera

Sensor 1/3" color CMOS

JPEG resolution Up to 1280 x 960

Video resolution 640 x 480

Frame rate 30 fps

Sensor sensitivity 5.6 V/lux-sec (550 nm)

Viewing angle 128° (H), 95° (V)

Technical Parameters

Camera

Infrared illumination	Yes
Sensor sensitivity without IR light	0.1 Lux ± 20 %
Focal length	2.25 mm

Video stream

Protocols	<ul style="list-style-type: none">• RTP• RTSP• HTTP
-----------	---

Video call codecs	<ul style="list-style-type: none">• H.263• H.264
-------------------	---

Set the video codec data flows in **Services > Phone > Video** for calls and in **Services > Streaming > RTSP** for streaming. The set bit rate represents the value that the codec has to approach on a long-time average. The data flow can vary depending on the scene to be scanned.

ONVIF/RTSP streaming codecs	<ul style="list-style-type: none">• H.264• MPEG-4• MJPEG
-----------------------------	--

IP Camera Function	Yes – compatible profiles: <ul style="list-style-type: none">• ONVIF v2.4 profile S
--------------------	---

Bandwidth used

Audio codecs	<ul style="list-style-type: none">• PCMA, PCMU – 64 kbps (with 85.6 kbps headers)• G.729 kbps – 16 bps (with 29.6 kbps headers)• G.722 – 64 kbps (with 85.6 kbps headers)• L16 / 16 kHz – 256 kbps (with 277.6 kbps headers)
--------------	---

Bandwidth used

Video Codecs

Set the video codec data flows for calls in **Services > Calls > SIP 1/2**. Set streaming in **Services > Streaming > RTSP**. The set bit rate represents the value that the codec has to approach on a long-time average. The data flow can vary depending on the scene to be scanned.

Interface

LAN

10/100BASE-TX with Auto-MDIX, RJ-45

Recommended cabling

Cat-5e or higher

Passive switch (relay)

NO/NC contact, up to 30 V / 1 A AC/DC

Active switch output

8 to 12 V DC according to power supply, up to 400 mA

- PoE: 10 V
- adapter: source voltage –2 V

Passive / active input

–30 V to +30 V DC

Bluetooth

Bluetooth

in compliance with BLE (Bluetooth Low Energy)

Security

Encoding:

- asymmetric RSA-1024
- symmetric AES-128

Range

Adjustable:

- short ~ 0.5 m
- medium ~ 2 m
- long ~ up to 10 m

RX sensitivity

up to –93 dBm

Technical Parameters

Bluetooth

Consumption	20 mA at 12 V DC
Operating temperature	-40 °C ~ +60 °C
Storing temperature	-40 °C ~ +70 °C
Dimensions	97 x 105 x 30 mm
Support of mobile applications	Android 10.0 and higher, iOS 17.0 and higher

Touch Display Module

Resolution	78 dB (for 1 kHz, distance 1 m)
Slideshow mode resolution	214 × 320 px, 214 x 214 px
Contrast ratio	400 : 1
Brightness	78 dB (for 1 kHz, distance 1 m)
Viewing angle	80° from all directions
Weight	280 g
Minimum consumption	1.36 W
Maximum consumption	2.40 W
Operating temperature	-20°C to 60°C
Resistance level	IK07
Directory	residential / business (for 10 000 users)

Technical Parameters

I/O module, Wiegand module

Dimensions 43 x 31.5 x 1.5 mm

Mechanical Parameters

Cover Robust zinc casting with surface finish (minor surface shade nuances are acceptable).

Body material Versions:

- Light version - Nickel:
 - Material - Zamak 410 - Zn95Al4Cu1
 - Surface treatment - Zn/Cu20/Ni25b max. 80 µm
- Black version:
 - Material - Zamak 410 - Zn95Al4Cu1
 - Surface treatment – PUR Wet coating 15–25 µm, RAL 25 Jet black, inner side - passivated zinc

Surface installation dimensions	One-module	107 x 130 x 28 mm
---------------------------------	------------	-------------------

	Two-module	107 x 234 x 28 mm
--	------------	-------------------

Flush installation dimensions	Frame – one-module	130 x 153 x 5 mm
-------------------------------	--------------------	------------------

	Frame – two-module	130 x 257 x 5 mm
--	--------------------	------------------

	Box (minimum wall hole) – one-module	108 x 131 x 45 mm
--	--------------------------------------	-------------------

	Box (minimum wall hole) – two-module	108 x 238 x 45 mm
--	--------------------------------------	-------------------

Technical Parameters

Mechanical Parameters

Weight (depending on configuration)

Max. net

2 kg

Max. gross

2.5 kg

Operating temperature

-40 °C to 60 °C

Relative humidity

10 to 95 % (non-condensing)

Storing temperature

-40 °C to 70 °C

Protection class

IP54

Resistance level

IK08

General Instructions and Cautions

Please read this User Manual carefully before using the product and follow the instructions and recommendations included therein.

Any use of the product that is in contradiction with the instructions provided herein may result in malfunction, damage or destruction of the product.

The manufacturer shall not be liable and responsible for any damage incurred as a result of a use of the product other than that included herein, namely undue application and disobedience of the recommendations and warnings.

Any use or connection of the product other than those included herein shall be considered undue and the manufacturer shall not be liable for any consequences arisen as a result of such misconduct.

Moreover, the manufacturer shall not be liable for any damage or destruction of the product incurred as a result of misplacement, incompetent installation and/or undue operation and use of the product in contradiction herewith.

The manufacturer assumes no responsibility for any malfunction, damage or destruction of the product caused by incompetent replacement of parts or due to the use of reproduction parts or components.

The manufacturer shall not be liable and responsible for any loss or damage incurred as a result of a natural disaster or any other unfavorable natural condition.

The manufacturer shall not be held liable for any damage of the product arising during the shipping thereof.

The manufacturer shall not make any warrant with regard to data loss or damage.

The manufacturer shall not be liable and responsible for any direct or indirect damage incurred as a result of a use of the product in contradiction herewith or a failure of the product due to a use in contradiction herewith.

All applicable legal regulations concerning the product installation and use as well as provisions of technical standards on electric installations have to be obeyed. The manufacturer shall not be liable and responsible for damage or destruction of the product or damage incurred by the consumer in case the product is used and handled contrary to the said regulations and provisions.

The consumer shall, at its own expense, procure software protection of the product. The manufacturer shall not be held liable for any damage incurred as a result of the use of deficient security software.

The consumer shall, without delay, change the access password for the product after installation. The manufacturer shall not be held liable or responsible for any damage incurred in connection with the use of the original password.

The manufacturer also assumes no responsibility for additional costs incurred by the consumer as a result of making calls to increased tariff lines.

Directives, Laws and Regulations

2N IP Verso conforms to the following directives and regulations:

EU

- 2012/19/EU on waste electrical and electronic equipment

- 2014/53/EU for radio equipment
- 2011/65/EU on the restriction of the use of certain hazardous substances in electrical and electronic equipment

Industry Canada

This Class B digital apparatus complies with Canadian ICES-003/NMB-003.

Compliance with DDA:

The 2N Telekomunikace devices comply with the Disability Discrimination Act (DDA) of 2005 stipulating the following conditions:

1. The devices are mounted in such a manner that their bottom edges are 100 to 120 centimeters above the ground.
2. The devices use keypads with a mechanical protrusion on digit 5.
3. The devices use an electromagnetic loop as the hearing aid.

Legislation of Japan

本製品は、特定無線設備の技術基準適合証明を受けています。

この装置は、クラス A 機器です。この装置を住宅環境で使用すると電波妨害を引き起こすことがあります。この場合には使用者が適切な対策を講ずるよう要求されることがあります。VCCI-A

本製品は、シールドネットワークケーブル(STP)を使用して接続してください。また適切に接地してください。

本製品は電気通信事業者（移動通信会社、固定通信会社、インターネットプロバイダ等）の通信回線（公衆無線 LAN を含む）に直接接続することができません。本製品をインターネットに接続する場合は、必ずルータ等を経由し接続してください。

Electric Waste and Used Battery Pack Handling



Do not place used electric devices and battery packs into municipal waste containers. An undue disposal thereof might impair the environment!

Deliver your expired household electric appliances and battery packs removed from them to dedicated dumpsites or containers or give them back to the dealer or manufacturer for environmental-friendly disposal. The dealer or manufacturer shall take the product back free of charge and without requiring another purchase. Make sure that the devices to be disposed of are complete.

Do not throw battery packs into fire. Battery packs may not be taken into parts or short-circuited either.



2N IP Verso – Installation Manual

© 2N Telekomunikace a. s., 2025

2N.com