



# 2N LTE Verso

## Installation Manual



# Table of Contents

<b>Symbols and Terms Used</b> .....	<b>4</b>
<b>Product Description</b> .....	<b>5</b>
Basic Features .....	5
Accessories .....	6
Accessories for Installation .....	6
External Antennas .....	9
Diagnostic device .....	9
Frames .....	10
Extenders .....	12
Power Supply .....	26
Licenses .....	27
Other accessories .....	27
Package Completeness Check .....	32
Module / Frame Package Completeness Check .....	33
<b>Installation</b> .....	<b>34</b>
Mechanical Installation .....	34
Flush mounting .....	36
Surface Installation .....	74
Stand Installation .....	93
Electric Installation .....	95
Power Supply .....	95
Power Supply Installation .....	96
Device Connectors .....	97
LTE Mobile Network Connection .....	101
Installation Completion .....	101
Frame Attachment .....	102
Name Tags .....	102
Nametag Insertion/Replacement .....	103
Tactile stickers .....	103
Most Frequent Installation Errors .....	104
<b>Main and Extending Modules</b> .....	<b>105</b>
Module Interconnection .....	105
Module Power Supply .....	107
Module Specifications .....	111
125 kHz RFID Card Reader Module .....	111
13.56 MHz, NFC RFID Card Reader Module .....	112
Secured 13.56 MHz NFC RFID Card Reader Module .....	112
Bluetooth & 125 kHz, 13.56 MHz, NFC RFID Card Reader Module .....	112
Bluetooth & 125 kHz, secured 13.56 MHz, NFC RFID Card Reader Module .....	113
Touch Keypad & 125 kHz, 13.56 MHz, NFC RFID Card Reader Module .....	114
Touch Keypad & 125 kHz, secured 13.56 MHz, NFC RFID Card Reader Module .....	114
Touch Keypad & Bluetooth & 125 kHz, 13.56 MHz, NFC RFID Card Reader Module .....	115
Touch Keypad & Bluetooth & 125 kHz, secured 13.56 MHz, NFC RFID Card Reader Module .....	115
Touch Keypad Module .....	116
Biometric Fingerprint Reader Module .....	116
Touch Display Module .....	117
5-Button Module .....	118
Keypad Module .....	118
I/O Module .....	118
Wiegand Module .....	120
Security Relay .....	124
Tamper Switch Module .....	126
OSDP Module .....	128

Induction Loop Module .....	132
Infopanel Module .....	132
Blind Panel Module .....	133
<b>Brief Guidelines .....</b>	<b>134</b>
Device Configuration Interface Access .....	134
Web Configuration Interface Login .....	134
Recommended browsers .....	134
Configuration via Hardware .....	135
Device Restart .....	135
Factory Default Reset with RESET Button .....	135
Firmware Update .....	135
Device Restart .....	135
Restart Using RESET Button .....	136
Restart Using Web Configuration Interface .....	136
Factory Default Reset with RESET Button .....	136
Factory Default Reset with RESET Button .....	136
<b>Device Control .....</b>	<b>137</b>
LED pictograms .....	139
Device Configuration via SMS Commands .....	139
<b>Maintenance - Cleaning .....</b>	<b>143</b>
<b>Troubleshooting .....</b>	<b>144</b>
<b>Technical Parameters .....</b>	<b>145</b>
<b>General Instructions and Cautions .....</b>	<b>153</b>
Directives, Laws and Regulations .....	153
EU .....	153
Industry Canada .....	154
Compliance with DDA: .....	154
Electric Waste and Used Battery Pack Handling .....	154

## Symbols and Terms Used

The following symbols and pictograms are used in the manual:



**DANGER**

**Always abide** by this information to prevent persons from injury.



**WARNING**

**Always abide** by this information to prevent damage to the device.



**CAUTION**

**Important information** for system functionality.



**TIP**

**Useful information** for quick and efficient functionality.



**NOTE**

Routines or advice for efficient use of the device.

# Product Description

In this section, we introduce the **2N LTE Verso** product, outline its application options and highlight the advantages following from its use.

## Basic Features

**2N LTE Verso** is an elegant and reliable LTE intercom equipped with HD camera, which can be assembled exactly according to your needs thanks its modularity. It ensures reliable control of the entrance to the building and allows you to easily connect with other systems, thus achieving even greater security of the building. Thanks to SIP support and compatibility with major IP PBX and phone manufacturers, it can benefit from using VoIP networks.

The device can be used as a door or special purpose intercom for office buildings, residential areas and/or other applications.

Thanks to its mobile LTE connection, the device can be installed on sites where no LAN cable connection is available. Thanks to its My2N connection, the device helps you call mobile phones and 2N answering units without complicated configuration.

The device is a modular system, allowing the user to choose a configuration that perfectly meets their individual needs. Unlike other intercoms, **2N LTE Verso** is not delivered as a compact unit. After choosing the installation mode and particular modules, the user gets separate parts to be assembled using the plug&play connections. This approach allows for unique individual combinations and also leaves space for adding of additional modules later on.



### CAUTION

- If combined with RFID readers, **2N LTE Verso** fails to meet the conditions of a supplementary regulation to the EU Radio Equipment Directive – effective from August 1, 2025. **2N LTE Verso 2.0** meets the conditions.  
Refer to [Impacts of the EU Radio Equipment Directive](#) for more details.
- Removing and displacing the LTE antenna stuck in the blind into another device part, e.g. under any card reader module, results in interference and device functionality deterioration.

## The main advantages of this device are:

**Wide Angle Camera with HD Resolution** – the calling persons can be displayed to the called user on the 2N answering units, the user phone or PC. The camera is elegantly hidden behind darkened glass, so it is not visible. The device is also equipped with a night vision system, which automatically selects the night/day mode according to the ambient light.

**Speed Dial Buttons** – the device can be equipped with a button module with up to 146 buttons. You can set up to three telephone numbers and call time profiles for each of the buttons to make the called user accessible any time. The buttons are backlit with a clear mechanical response and backlit metal finger pad. The nametag surface is resistant to mechanical damage.

**Keypad** – the device can be equipped with a numeric keypad module, which allows the user to use the device as a code lock for lock switch activation and/or dialing a defined phone number or user number.

**Card Reader** – the device can be equipped with a card reader module, which provides access control functionality based on RFID cards or chips. With additional software features, functions other than the door lock can be RFID card controlled too.

**Electric Lock Switch** – this switch can be controlled via a numeric keypad, PC application or any phone during a call. If necessary, more modules with required outputs can be added. A wide range of switch settings allows for a variety of applications.

**Robustness** – the device is designed as a robust, mechanically resistant intercom, which withstands weather conditions without needing extra accessories.

**Audio Quality**– thanks to the integrated acoustic echo cancellation (AEC) system, full duplex communication provides bilateral audibility even when the calling users are speaking at the same time.

**Device Installation** – is very easy. All you have to do is assemble the required modules, insert a SIM card, connect the power supply. The modules are plug&play, so there is no need to configure them manually. The device is supplied from a 12 V power source.

**Device Configuration** – use a PC equipped with any Internet browser for configuration. Extensive installations can be easily managed in bulk using 2N Access Commander.

## Other advantages of the device

## Accessories

### Accessories for Installation

**2N LTE Verso** is designed for both outdoor and indoor applications and requires no additional roof.

Choose the proper frame and, if necessary, other accessories for your particular installation needs.

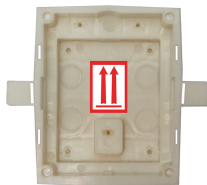

#### **Part No. 9155014**

Axis Part No. 01284-001

Flush mounting box, 1-module

The box is designed for brick/plasterboard flush mounting of 1-module.

Delivered including accessories for multiple box assemblies.

**Remember to order it together with a 1-module flush mounting frame (9155011/9155011B, 01278-001/01279-001).**



#### **Part No. 9155015**

Axis Part No. 01285-001

Flush mounting box, 2-module

The box is designed for brick/plasterboard flush mounting of 2-module.

Delivered including accessories for multiple box assemblies.

**Remember to order it together with a 2-module flush mounting frame (9155012/9155012B, 01280-001/01281-001).**

## Product Description



### **Part No. 9155016**

Axis Part No. 01286-001

Flush mounting box, 3-module

The box is designed for brick/plasterboard flush mounting of 3-module.

Delivered including accessories for multiple box assemblies.

**Remember to order it together with a 3-module flush mounting frame (9155013/9155013B, 01282-001/01283-001).**

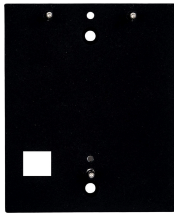

### **Part No. 9155061**

Axis Part No. 01293-001

1-module mounting backplate

Mounting backplate for glass/uneven surface mounting of 1 module.



### **Part No. 9155062**

Axis Part No. 01294-001

2-module mounting backplate

Mounting backplate for glass/uneven surface mounting of 2 modules.



### **Part No. 9155063**

Axis Part No. 01295-001

3-module mounting backplate

Mounting backplate for glass/uneven surface mounting of 3 modules.

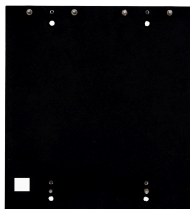

### **Part No. 9155064**

Axis Part No. 01296-001

2 x 2-module mounting backplate

Mounting backplate for glass/uneven surface mounting of 2 (w) x 2 (h) modules.

---

## Product Description

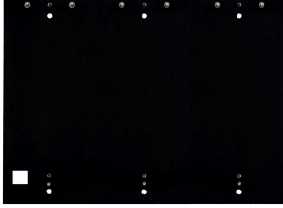

### **Part No. 9155065**

Axis Part No. 01297-001

3 x 2-module mounting backplate

Mounting backplate for glass/uneven surface mounting of 3 (w) x 2 (h) modules.

---



### **Part No. 9155066**

Axis Part No. 01298-001

2 x 3-module mounting backplate

Mounting backplate for glass/uneven surface mounting of 2 (w) x 3 (h) modules.

---

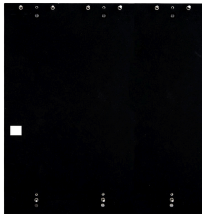

### **Part No. 9155067**

Axis Part No. 01299-001

3 x 3-module mounting backplate

Mounting backplate for glass/uneven surface mounting of 3 (w) x 3 (h) modules.

---



### **Part No. 9155072**

Axis Part No. 01940-001

2-module slope board

The 2-module slope board is used as a backplate for installations with a tilt of 25°.

---



### **Part No. 9155050/9155054/9155055**

Axis Part No. 01267-001/01268-001/01269-001

1/3/5 m interconnecting cable

Interconnection cable for distant module installation.

Only one interconnecting cable is allowed per installation.

The maximum bus length is 7 m.

---

## Product Description



### **Part No. 9155010**

Axis Part No. 03343-001

2N IP Verso – Mounting cover for stand

Mounting cover for the 2N IP Verso device for installation on a stand.

## External Antennas



### **Part No. 9155048**

Axis Part No. 01943-001

**2N LTE Verso** – external antenna

An optional accessory in case the signal is weak with an internal antenna in a blind.

- suitable for all LTE networks
- Gain: 4.1 dB
- Cable length: 2 m

## Diagnostic device



### **Part No. 9155049**

Axis Part No. 02284-001

**2N LTE Verso** – debug LAN module

The module helps you detect failures and configure the device.

- European LTE support
- HD camera

One blind module with a stuck LTE antenna is supplied with each main unit.

We do not recommend installation in places exposed to direct sunlight.

## Frames

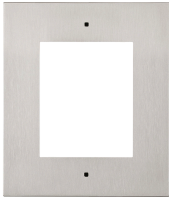

**Part No. 9155011**

Axis Part No. 01278-001

Flush mounting frame, 1 module

Covering frame for the 1-module brick/plasterboard flush mounting box.

The 1-module frame is used, for example:

- When an additional module is added to an existing installation.
- When the module is mounted onto an extended interconnecting cable, for an OUT card reader, for example.

**Remember to order the frame when you order a 1-module flush mounting box (9155014, 01284-001)**

---



**Part No. 9155011B**

Axis Part No. 01279-001

Flush mounting frame, 1 module – black

Covering frame for the 1-module brick/plasterboard flush mounting box.

The 1-module frame is used, for example:

- When an additional module is added to an existing installation.
- When the module is mounted onto an extended interconnecting cable, for an OUT card reader, for example.

**Remember to order the frame when you order a 1-module flush mounting box (9155014, 01284-001)**

---



**Part No. 9155012**

Axis Part No. 01280-001

Flush mounting frame, 2 modules

Covering frame for the 2-module brick/plasterboard flush mounting box.

**Remember to order the frame when you order a 2-module flush mounting box (9155015, 01285-001).**

---

## Product Description



### **Part No. 9155012B**

Axis Part No. 01281-001

Flush mounting frame, 2 modules – black

Covering frame for the 2-module brick/plasterboard flush mounting box.

**Remember to order the frame when you order a 2-module flush mounting box (9155015, 01285-001).**

---



### **Part No. 9155013**

Axis Part No. 01282-001

Flush mounting frame, 3 modules

Covering frame for the 3-module brick/plasterboard flush mounting box.

**Remember to order the frame when you order a 3-module flush mounting box (9155016, 01286-001).**

---



### **Part No. 9155013B**

Axis Part No. 01283-001

Flush mounting frame, 3-module – black

Covering frame for the 3-module brick/plasterboard flush mounting box.

**Remember to order the frame when you order a 3-module flush mounting box (9155016, 01286-001).**

---

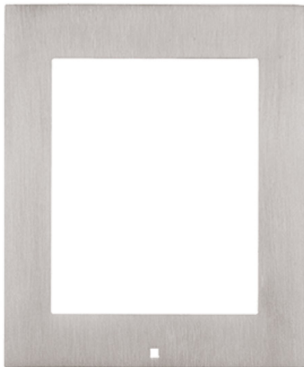

### **Part No. 9155021**

Axis Part No. 01287-001

Surface mounting frame, 1 module

The 1-module frame is used, for example:

- when an additional module is added to an existing installation,
  - when the module is mounted onto an extended interconnecting cable, for an OUT card reader, for example.
-

## Product Description



**Part No. 9155021B**

Axis Part No. 01288-001

Surface mounting frame, 1 module – black

The 1-module frame is used, for example:

- when an additional module is added to an existing installation,
- when the module is mounted onto an extended interconnecting cable, for an OUT card reader, for example.



**Part No. 9155022**

Axis Part No. 01289-001

Surface mounting frame, 2 modules



**Part No. 9155022B**

Axis Part No. 01290-001

Surface mounting frame, 2 modules – black



**Part No. 9155023**

Axis Part No. 01291-001

Surface mounting frame, 3 modules



**Part No. 9155023B**

Axis Part No. 01292-001

Surface mounting frame, 3 modules – black

## Extenders

## Product Description



### **Part No. 9155030**

Axis Part No. 01252-001

2N IP Verso – Infopanel

The Infopanel module helps you place such information into the device installation as house number, opening hours and similar data.

The Infopanel backlight is software controlled.

---



### **Part No. 9155031**

Axis Part No. 01253-001

2N IP Verso – Keypad

The numeric keypad module helps you dial users via their phonebook positions or phone numbers. Also, it helps you control the lock and other functions via a numeric code.

The digits and symbols are backlit.

---



### **Part No. 9155031B**

Axis Part No. 01254-001

2N IP Verso – Keypad – black

The numeric keypad module helps you dial users via their phonebook positions or phone numbers. Also, it helps you control the lock and other functions via a numeric code.

The digits and symbols are backlit.

---



### **Part No. 9155035**

Axis Part No. 01258-001

2N IP Verso – 5-button

A module with 5 mechanical speed dial buttons.

The buttons are backlit and can include nametags.

---



**CAUTION**

In combination with the **2N LTE Verso** intercom, this RFID reader does not meet the conditions of the supplementary regulation to the EU Radio Equipment Directive - effective from 1 August 2025. In combination with the **2N IP Verso 2.0** intercom, it meets the requirements.

Refer to [Impacts of the EU Radio Equipment Directive](#) for more details.

**Part No. 9155041**

Axis Part No. 01263-001

2N IP Verso – Induction Loop

The induction loop is used for transmitting audio signals directly into hearing aids via a magnetic field.

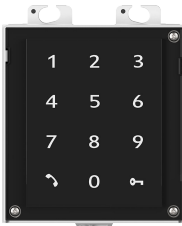

**Part No. 9155047**

Axis Part No. 01277-001

2N IP Verso – Touch Keypad

The numeric touch keypad module helps you dial users via their phonebook positions or phone numbers, Also, it helps you control the lock and other functions via a numeric code.

The digits and symbols are backlit.

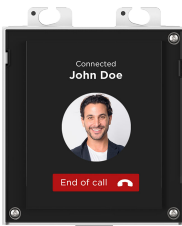

**Part No. 9155036**

Axis Part No. 01275-001

2N IP Verso – Touch Display

The touch display module allows visitors to dial users in a smartphone-like way.

In addition to a structured phonebook, the display also features a keypad.

## Product Description



### CAUTION

In combination with the **2N LTE Verso** intercom, this RFID reader does not meet the conditions of the supplementary regulation to the EU Radio Equipment Directive - effective from 1 August 2025. In combination with the **2N IP Verso 2.0** intercom, it meets the requirements.

Refer to [Impacts of the EU Radio Equipment Directive](#) for more details.

### Part No. 91550941

2N IP Verso 125 kHz

It provides access control via contactless cards or key fobs.

Supported RFID cards 125 kHz:

- EM4x02
- NXP HiTag2



### CAUTION

In combination with the **2N LTE Verso** intercom, this RFID reader does not meet the conditions of the supplementary regulation to the EU Radio Equipment Directive - effective from 1 August 2025. In combination with the **2N IP Verso 2.0** intercom, it meets the requirements.

Refer to [Impacts of the EU Radio Equipment Directive](#) for more details.

### Part No. 91550941US

Axis Part No. 02140-001

2N IP Verso 125 kHz

It provides access control via contactless cards or key fobs.

Supported RFID cards 125 kHz:

- EM4x02
  - NXP HiTag2
-



**CAUTION**

In combination with the **2N LTE Verso** intercom, this RFID reader does not meet the conditions of the supplementary regulation to the EU Radio Equipment Directive - effective from 1 August 2025. In combination with the **2N IP Verso 2.0** intercom, it meets the requirements.

Refer to [Impacts of the EU Radio Equipment Directive](#) for more details.

**Part No. 91550942**

Axis Part No. 02139-001

2N IP Verso 13.56 MHz, NFC ready

It provides access control via contactless cards or key fobs. The module supports the following 13.56 MHz cards or other carriers:

Supported RFID cards 13.56 MHz:

- **ISO14443A** (MIFARE Classic, MIFARE Plus, MIFARE Mini, MIFARE Ultralight, MIFARE DESFire CSN only)
- **PicoPass** (HID iClass CSN, Picopass)
- **FeliCa** (Standard, Lite)
- **ST SR** (SR, SRI, SRIX)
- **My2N**
- **2N PICard**

## Product Description



### CAUTION

In combination with the **2N LTE Verso** intercom, this RFID reader does not meet the conditions of the supplementary regulation to the EU Radio Equipment Directive - effective from 1 August 2025. In combination with the **2N IP Verso 2.0** intercom, it meets the requirements.

Refer to [Impacts of the EU Radio Equipment Directive](#) for more details.

### Part No. 91550942-S

Axis Part No. 02141-001

2N IP Verso 13.56 MHz, secured NFC ready

It provides access control via contactless cards or key fobs. The module supports the following 13.56 MHz cards or other carriers:

Supported RFID cards 13.56 MHz:

- **ISO14443A** (MIFARE Classic, MIFARE Plus, MIFARE Mini, MIFARE Ultralight, MIFARE DESFire CSN only)
- **PicoPass** (HID iClass CSN, Picopass)
- **FeliCa** (Standard, Lite)
- **ST SR** (SR, SRI, SRIX)
- **HID PAC** (HID SEOS, HID iClass SE, iClass SR, HID MIFARE DESFire with SIO, HID MIFARE Classic with SIO)
- **My2N**
- **2N PICard**



### Part No. 91550451

Axis Part No. 03507-001

2N IP Verso – Biometric Fingerprint Reader

Used for verification of human fingerprints for access control and intercom/third party equipment control.



**CAUTION**

In combination with the **2N LTE Verso** intercom, this RFID reader does not meet the conditions of the supplementary regulation to the EU Radio Equipment Directive - effective from 1 August 2025. In combination with the **2N IP Verso 2.0** intercom, it meets the requirements.

Refer to [Impacts of the EU Radio Equipment Directive](#) for more details.

**Part No. 9155086**

Axis Part No. 01712-001

2N IP Verso RFID – secured 13.56 MHz, NFC

It provides access control via contactless cards or key fobs. The module supports the following 13.56 MHz cards or other carriers:

Compatible with firmware version 2.13 and higher.

Supported RFID cards 13.56 MHz:

- **ISO14443A** (MIFARE Classic, MIFARE Plus, MIFARE Mini, MIFARE Ultralight, MIFARE DESFire CSN only)
  - **PicoPass** (HID iClass CSN, Picopass)
  - **FeliCa** (Standard, Lite)
  - **ST SR** (SR, SRI, SRIX)
  - **My2N**
  - **2N PICard**
-



**CAUTION**

In combination with the **2N LTE Verso** intercom, this RFID reader does not meet the conditions of the supplementary regulation to the EU Radio Equipment Directive - effective from 1 August 2025. In combination with the **2N IP Verso 2.0** intercom, it meets the requirements.

Refer to [Impacts of the EU Radio Equipment Directive](#) for more details.

**Part No. 91550945**

Axis Part No. 02778-001

2N IP Verso Bluetooth & RFID – 125 kHz, 13.56 MHz, NFC

A combined Bluetooth & card reader module helps you control access using a numeric code, contactless cards or key fobs. The module supports the 125 kHz and 13.56 MHz cards and/or other carriers.

Supported RFID cards 125 kHz:

- EM4x02
- NXP HiTag2

Supported RFID cards 13.56 MHz:

- **ISO14443A** (MIFARE Classic, MIFARE Plus, MIFARE Mini, MIFARE Ultralight, MIFARE DESFire CSN only)
  - **PicoPass** (HID iClass CSN, Picopass)
  - **FeliCa** (Standard, Lite)
  - **ST SR** (SR, SRI, SRIX)
  - **My2N**
  - **2N PICard**
-



### CAUTION

In combination with the **2N LTE Verso** intercom, this RFID reader does not meet the conditions of the supplementary regulation to the EU Radio Equipment Directive - effective from 1 August 2025. In combination with the **2N IP Verso 2.0** intercom, it meets the requirements.

Refer to [Impacts of the EU Radio Equipment Directive](#) for more details.

### Part No. 91550945-S

Axis Part No. 02444-001

2N IP Verso Bluetooth & RFID – 125 kHz, secured 13.56 MHz, NFC

A combined Bluetooth – card reader module helps you control access using an access code, My2N in your smartphone or an access card. The module supports the 125 kHz and 13.56 MHz cards and/or other carriers.

Supported RFID cards 125 kHz:

- EM4x02
- NXP HiTag2

Supported RFID cards 13.56 MHz:

- **ISO14443A** (MIFARE Classic, MIFARE Plus, MIFARE Mini, MIFARE Ultralight, MIFARE DESFire CSN only)
  - **PicoPass** (HID iClass CSN, Picopass)
  - **FeliCa** (Standard, Lite)
  - **ST SR** (SR, SRI, SRIX)
  - **HID PAC** (HID SEOS, HID iClass SE, iClass SR, HID MIFARE DESFire with SIO, HID MIFARE Classic with SIO)
  - **My2N**
  - **2N PICard**
-



### CAUTION

In combination with the **2N LTE Verso** intercom, this RFID reader does not meet the conditions of the supplementary regulation to the EU Radio Equipment Directive - effective from 1 August 2025. In combination with the **2N IP Verso 2.0** intercom, it meets the requirements.

Refer to [Impacts of the EU Radio Equipment Directive](#) for more details.

### Part No. 91550946

Axis Part No. 02779-001

2N IP Verso Touch keypad & RFID – 125 kHz, 13.56 MHz, NFC

A combined touch keypad – card reader module helps you control access using a numeric code, contactless cards or key fobs. The module supports the 125 kHz and 13.56 MHz cards and/or other carriers.

Supported RFID cards 125 kHz:

- EM4x02
- NXP HiTag2

Supported RFID cards 13.56 MHz:

- **ISO14443A** (MIFARE Classic, MIFARE Plus, MIFARE Mini, MIFARE Ultralight, MIFARE DESFire CSN only)
  - **PicoPass** (HID iClass CSN, Picopass)
  - **FeliCa** (Standard, Lite)
  - **ST SR** (SR, SRI, SRIX)
  - **My2N**
  - **2N PICard**
-



### CAUTION

In combination with the **2N LTE Verso** intercom, this RFID reader does not meet the conditions of the supplementary regulation to the EU Radio Equipment Directive - effective from 1 August 2025. In combination with the **2N IP Verso 2.0** intercom, it meets the requirements.

Refer to [Impacts of the EU Radio Equipment Directive](#) for more details.

### Part No. 91550946-S

Axis Part No. 02443-001

2N IP Verso Touch keypad & RFID – 125 kHz, secured 13.56 MHz, NFC

A combined touch keypad – card reader module helps you control access using a numeric code, contactless cards or key fobs. The module supports the 125 kHz and 13.56 MHz cards and/or other carriers.

Supported RFID cards 125 kHz:

- EM4x02
- HID Prox

Supported RFID cards 13.56 MHz:

- **ISO14443A** (MIFARE Classic, MIFARE Plus, MIFARE Mini, MIFARE Ultralight, MIFARE DESFire CSN only)
  - **PicoPass** (HID iClass CSN, Picopass)
  - **FeliCa** (Standard, Lite)
  - **ST SR** (SR, SRI, SRIX)
  - **HID PAC** (HID SEOS, HID iClass SE, iClass SR, HID MIFARE DESFire with SIO, HID MIFARE Classic with SIO)
  - **My2N**
  - **2N PICard**
-



### CAUTION

In combination with the **2N LTE Verso** intercom, this RFID reader does not meet the conditions of the supplementary regulation to the EU Radio Equipment Directive - effective from 1 August 2025. In combination with the **2N IP Verso 2.0** intercom, it meets the requirements.

Refer to [Impacts of the EU Radio Equipment Directive](#) for more details.

### Part No. 91550947

Axis Part No. 02781-001

2N IP Verso Touch keypad & Bluetooth & RFID – 125 kHz, 13.56 MHz, NFC

A combined touch keypad – Bluetooth – card reader module helps you control access using an access code, My2N in your smartphone or an access card. The module supports the 125 kHz and 13.56 MHz cards and/or other carriers.

Supported RFID cards 125 kHz:

- EM4x02
- NXP HiTag2

Supported RFID cards 13.56 MHz:

- **ISO14443A** (MIFARE Classic, MIFARE Plus, MIFARE Mini, MIFARE Ultralight, MIFARE DESFire CSN only)
  - **PicoPass** (HID iClass CSN, Picopass)
  - **FeliCa** (Standard, Lite)
  - **ST SR** (SR, SRI, SRIX)
  - **My2N**
  - **2N PICard**
-



### CAUTION

In combination with the **2N LTE Verso** intercom, this RFID reader does not meet the conditions of the supplementary regulation to the EU Radio Equipment Directive - effective from 1 August 2025. In combination with the **2N IP Verso 2.0** intercom, it meets the requirements.

Refer to [Impacts of the EU Radio Equipment Directive](#) for more details.

### Part No. 91550947-S

Axis Part No. 02782-001

2N IP Verso Touch keypad & Bluetooth & RFID - 125 kHz, secured 13.56 MHz, NFC

A combined touch keypad – Bluetooth – card reader module helps you control access using an access code, My2N in your smartphone or an access card. The module supports the 125 kHz and 13.56 MHz cards and/or other carriers.

Supported RFID cards 125 kHz:

- EM4x02
- HID Prox

Supported RFID cards 13.56 MHz:

- **ISO14443A** (MIFARE Classic, MIFARE Plus, MIFARE Mini, MIFARE Ultralight, MIFARE DESFire CSN only)
- **PicoPass** (HID iClass CSN, Picopass)
- **FeliCa** (Standard, Lite)
- **ST SR** (SR, SRI, SRIX)
- **HID PAC** (HID SEOS, HID iClass SE, iClass SR, HID MIFARE DESFire with SIO, HID MIFARE Classic with SIO)
- **My2N**
- **2N PICard**



### Part No. 9155039

Axis Part No. 01261-001

2N IP Verso – Blind Panel

The blind panel module helps fill up redundant space in installations.

The main unit is supplied with one blind panel module.

## Product Description



### **Part No. 9155034**

Axis Part No. 01257-001

I/O Module

The module provides logical inputs and outputs for integration of sensors or other devices.

The module is installed under another module, i.e. needs no separate position.

---



### **Part No. 9155037**

Axis Part No. 01259-001

Wiegand Module

The Wiegand module helps you interconnect your system with other systems via the Wiegand interface.

The module is installed under another module, i.e. needs no separate position.

---



### **Part No. 91550371**

Axis Part No. 02577-001

OSDP Module

The OSDP module provides OSDP communication with a connected OSDP device (control panel, door controller) and **2N LTE Verso** (placed outside).

The module is installed under another module, i.e. needs no separate position.

---

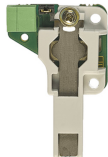

### **Part No. 9155038**

Axis Part No. 01260-001

Tamper Switch

Tamper Switch is a module which detects that the device has been opened or the top cover removed.

The module is installed under another module, i.e. needs no separate position.

Remember to purchase the I/O module (9155034, 01257-001), along with the Tamper Switch.

---

## Product Description

### Part No. 9159010



Axis Part No. 01386-001

Security Relay

A handy add-on that significantly enhances security. It prevents lock tampering.

To be installed between the protected device from which it is also powered and the lock controlled by it.

---

### Part No. 9155198SET



Axis Part No. 01975-001

Security Package for 2N Devices

The security package provides increased door security.

The safety package includes a safety relay, a protection switch and an I/O module.

---

## Power Supply

### Part No. 91341481E (with EU cable)



### Part No. 91341481US (with US cable)

Axis Part No. 02520-001

Stabilized 12 V / 2 A power supply

The supply must be used where PoE is not used.

---

### Part No. 932928



Axis Part No. 02529-001

12 V transformer

For 230 V mains voltage.

Designed for external supply of electric locks.

---

### Part No. 9159052



Axis Part No. 01393-001

12 V / 1 A power supply for 2N Induction Loop

The external induction loop power supply has 230 V AC input voltage and 12 V DC output voltage.

## Licenses



**Part No. 9137909**

Axis Part No. 01380-001

Gold License

Includes the Enhanced Video, Enhanced Integration and Lift Control licenses.

---



**Part No. 9137910**

Axis Part No. 01381-001

InformaCast License

---



**Part No. 9137921**

Axis Part No. 03160-001

MS Teams license



**TIP**

- Refer to the Configuration Manual for 2N IP Intercoms, Subs. [Function Licensing](#) for details.
- Please refer to the local 2N distributor for more accessories and recommendations.

## Other accessories



**Part No. 9159013**

Axis Part No. 02523-001

Departure button

The departure button is connected to the device logic input for opening the door from inside the building.

---

## Product Description



### **Part No. 9159012**

Axis Part No. 01388-001

Magnetic door contact

Set for installation on a door, enabling the status of door opening to be ascertained. Used where the device is used for door protection, open door detection or forced opening.

---



### **Part No. 9134173**

Axis Part No. 01384-001

MIFARE RFID chip card, 13.56 Hz

RFID chip card, MIFARE Classic 1k, 13.56 MHz.

---



### **Part No. 9134174**

Axis Part No. 01385-001

MIFARE RFID chip fob, 13.56 MHz

RFID chip fob, MIFARE Classic 1k, 13.56 MHz.

---



### **Part No. 9134165E**

Axis Part No. 01395-001

EM RFID chip card, 125 Hz

RFID chip card, type EM4100, 125 kHz.

---



### **Part No. 9134166E**

Axis Part No. 01396-001

EM RFID chip fob, 125 kHz

RFID chip fob, type EM4100, 125 kHz.

---

## Product Description

### Part No. 11202601

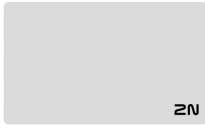

Axis Part No. 02787-001

MIFARE DESFire RFID chip card, 13.56 MHz

RFID chip fob, type MIFARE DESFire EV3 4 K, 13.56 MHz (ISO/IEC14443A).

Suitable for data encryption in PICArd Commander.

The package includes 10 pieces.

---

### Part No. 11202602



Axis Part No. 02788-001

MIFARE DESFire RFID fob, 13.56 MHz

RFID fob, type MIFARE DESFire EV3 4 K, 13.56 MHz (ISO/IEC14443A).

Suitable for data encryption in PICArd Commander.

The package includes 10 pieces.

---

### Part No. 9137420E



Axis Part No. 01399-001

External RFID reader, 125 kHz

External RFID card reader connectable to a PC via a USB interface.

Suitable for system administration and adding of EM41xx cards (125 kHz) using the device web configuration or PICArd Commander.

---

## Product Description



### Part No. 9137421E

Axis Part No. 01399-001

External RFID reader, 13.56 MHz + 125 kHz, NFC/HCE

External RFID card reader connectable to a PC via a USB interface.

Suitable for system administration and adding of 13.56 MHz/125 kHz cards and Android devices with NFC/HCE support using the device web configuration or the Access Commander.

Suitable for uploading of MIFARE DESFire cards into the PICard Commander encryption application.

The following RFID cards can be read:

Supported RFID cards 125 kHz:

- EM4x02
- NXP HiTag2

Supported RFID cards 13.56 MHz:

- **ISO14443A** (MIFARE Classic, MIFARE Plus, MIFARE Mini, MIFARE Ultralight, MIFARE DESFire CSN only)
- **PicoPass** (HID iClass CSN, Picopass)
- **FeliCa** (Standard, Lite)
- **ST SR** (SR, SRI, SRIX)
- **My2N**
- **2N PICard**

The device can also read the 13.56 MHz 2N PICard RFID cards.

---

## Product Description

### Part No. 9137424E



Axis Part No. 01527-001

External secured RFID reader, 13.56 MHz + 125 kHz, NFC/HCE

External secured RFID card reader connectable to a PC via a USB interface.

Suitable for system administration and adding of 13.56 MHz/125 kHz cards and Android devices with NFC/HCE support using the device web configuration or the Access Commander.

Suitable for uploading of MIFARE DESFire cards into the PICard Commander encryption application.

The following RFID cards can be read:

Supported RFID cards 125 kHz:

- EM4x02
- HID Prox

Supported RFID cards 13.56 MHz:

- **ISO14443A** (MIFARE Classic, MIFARE Plus, MIFARE Mini, MIFARE Ultralight, MIFARE DESFire CSN only)
- **PicoPass** (HID iClass CSN, Picopass)
- **FeliCa** (Standard, Lite)
- **ST SR** (SR, SRI, SRIX)
- **HID PAC** (HID SEOS, HID iClass SE, iClass SR, HID MIFARE DESFire with SIO, HID MIFARE Classic with SIO)
- **My2N**
- **2N PICard**

---

### Part No. 9137423E



Axis Part No. 01401-001

External fingerprint reader (USB interface)

External fingerprint reader connectable to a PC via a USB interface.

---

## Product Description

### Part No. 9159014EU/US/UK



Axis Part No. 01404-001

2N 2Wire (set of 2 adaptors and power source for EU/US/UK)

The 2N 2Wire converter allows you to use the existing 2-wire cabling from your original doorbell or door intercom for connecting any IP device. You do not have to configure anything, all you need is one 2N 2Wire unit at each end of the cable and a power supply connected to at least one of these units. The 2N 2Wire unit then provides PoE power not only to the second converter, but to all of the connected IP end devices.

---

### Part No. 9137422E



Axis Part No. 01402-001

2N IP Intercom – External Bluetooth reader (USB interface)

An external Bluetooth reader is connected to your computer via USB. It can be used for pairing the new users who want to use their smartphones with the **2N My2N** application for access to controlled areas.

A USB driver is required for the external reader to work properly.

---

### Part No. 9155051



Axis Part No. 01270-001

2N LTE VersoOne-button blind

The one-button blind helps blind a button on the main unit.

---

### Part No. 9155051B



Axis Part No. 01523-001

2N LTE VersoOne-button blind, black version

The one-button blind helps blind a button on the main unit.

## Package Completeness Check

Please check the product delivery before installation. Contents:

1x **2N LTE Verso**

---

1x Certificate of ownership

---

## Product Description

1x Brief Manual

---

1x Hex key

---

3x 3 x 8 mm stainless steel thread-forming lens head screw for plastic

---

1x stainless steel cylinder head screw into plastic

---

2x Frame fitting

## Module / Frame Package Completeness Check

The package of modules for **2N LTE Verso** includes:

3x 3 x 8 mm stainless steel thread-forming lens head screw for plastic

The package of frames for **2N LTE Verso** includes:

**Part Nos. 9155011, 9155011B, 9155012, 9155012B, 9155013, 9155013B**

**Axis Part Numbers 01278-001, 01279-001, 01280-001, 01281-001, 01282-001, 01283-001**

---

3x 4 x 20 mm stainless steel thread-forming lens head screw for plastic

**Part Nos. 9155021, 9155021B, 9155022, 9155022B, 9155023, 9155023B**

**Axis Part Numbers 01287-001, 01288-001, 01289-001, 01290-001, 01291-001, 01292-001**

---

2x 4 x 50 mm stainless steel flat head screw

---

2x 8 x 40 mm dowel



### CAUTION

If spare accessories other than the specified types are used, the device warranty might become null and void.

# Installation

For optimum functionality, it is recommended that the device is placed at a height according to the following scheme:

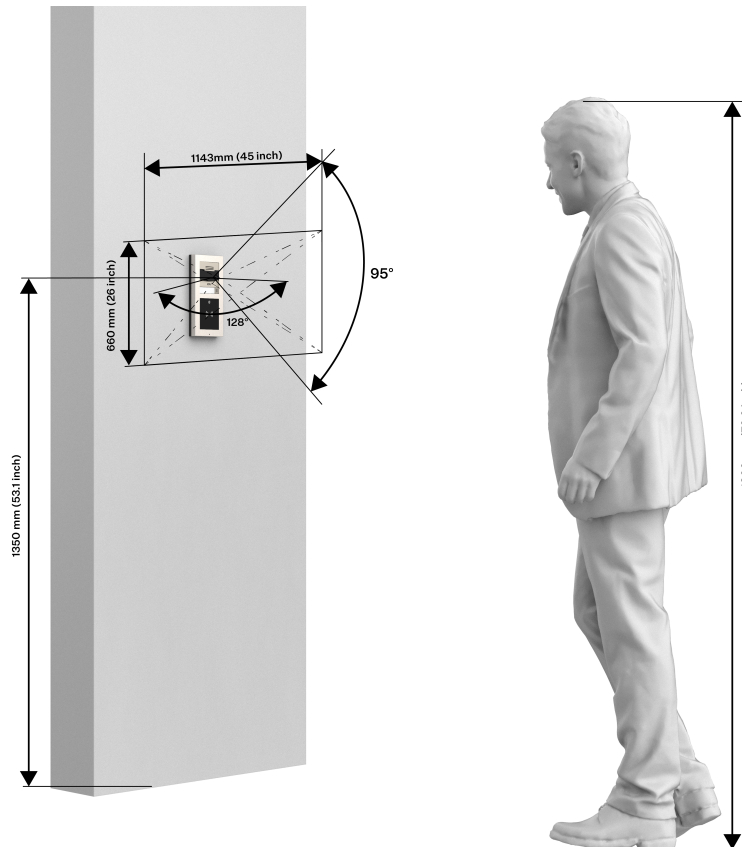

## Mechanical Installation

### Installation Conditions

**Make sure that the following 2N LTE Verso installation conditions are met.**

- There must be enough space for the device installation.
- Make sure that the dowel holes have the required diameter. If the diameters are too large, the dowels may get loose! Use the mounting glue to secure the dowels if necessary.
- Do not use low-quality dowels to avoid their falling out of the wall!
- Make sure that the depths of the dowel holes are accurate!
- Before starting the mechanical installation on a selected place, make sure carefully that the preparations associated with it (drilling, wall cutting) cannot damage the electrical, gas, water and other existing wires and pipes.
- The device is designed for vertical wall mounting (perpendicular to the floor) in the height of up to 1350 mm above the floor. If necessary, operate the device in a position other than as aforementioned for a short time only, for quick testing purposes in a servicing center, for example.
- Make sure that the plasterboard interior does not show a pressure value significantly different from that of the room, e.g. that it is not connected with overpressure ventilation. If the difference is too great, separate the device in terms of pressure (using, e.g., a mounting box) and seal the cable passage.

## Installation

- The device is not designed for environments with increased vibrations such as means of transport, machine rooms and so on.
- The device may not be exposed to aggressive gas, acid vapors, solvents, etc.
- The device is not intended for direct connection into the Internet/WAN. The device must be connected to the Internet/WAN via a separating active network element (switch/router).
- Having removed the front panel, make sure that no dirt gets inside the product, especially onto the sealing surface.
- Avoid strong electromagnetic radiation on the installation site.



### WARNING



- Make sure that the main unit is not removed from its base, that is why never remove the marked screw covered in resin in the right-hand upper corner. Any screw tampering results in the warranty becoming null and void.
- The grounding element in the left-hand upper corner of the unit must remain undamaged and stuck all the time.



- It is forbidden to use silicone or any other sealing material on the marked and hatched places.



### CAUTION

- When the proper installation instructions are not met, water might get in and destroy the electronics. As the device circuits are constantly under voltage water leakage causes electrochemical reaction. The manufacturer's warranty shall be void for products damaged in this way!
- Exceeding the allowed operating temperature may not affect the device immediately but leads to premature ageing and lower reliability. For the acceptable range of operating temperatures and relative humidity values refer to [S. Technical Parameters \(p. 145\)](#).
- Any intentional mechanical damage to the device (drilling, main unit tampering, etc.) results in a loss of warranty.
- The device installation and setting should only be performed by professionally qualified persons.

## Installation Tips

- The recommended height is 135 cm for standard installations (100–120 cm for disabled persons) from the floor to the device camera level. The installation heights may vary depending on the device use.

Viewing angle 125° (H), 105° (V)

- Flush mounting is recommended. It makes the product more elegant looking, more vandal resistant and more secure.
- The mounting box can be purchased in advance. Thus, a building company can be commissioned to do the rough work. The mounting box also helps you put your device exactly in the vertical position.

## Flush mounting

While flush mounting, make sure that the box is installed properly, i.e. with the box edge on the wall surface. There are stops on the box sides to secure a proper position. Remember to break them off after walling in. Make sure that the frame is placed precisely on the box without touching the wall to make the sealing fully functional. It is recommended that some universal/sanitary silicone, which is inert to the surface and UV and water resistant, is used to prevent water from penetrating into the device. Refer to the detailed pictorial instructions inside the package.



### WARNING



It is forbidden to use silicone or any other sealing material on the marked and hatched places (on the device bottom in particular).

**Flush mounting – into classic bricks, hollow bricks, thermally insulated fronts, etc.**

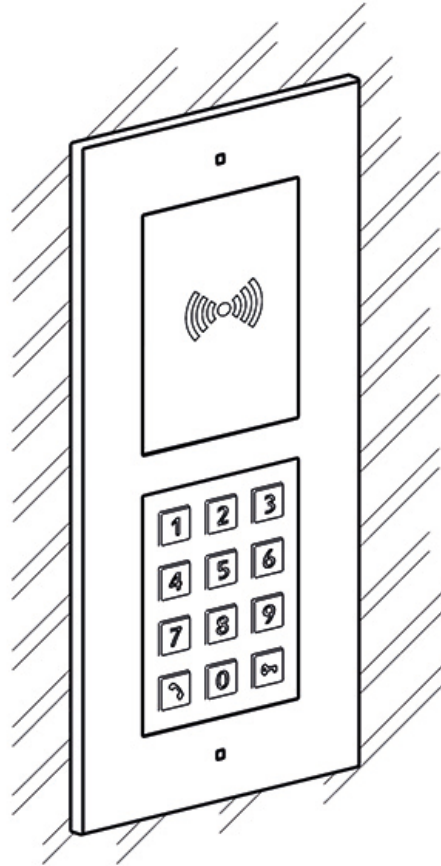

What you need for mounting:

- **2N LTE Verso**
- a properly cut hole as instructed in the box package
- plaster, mounting glue, mounting foam or mortar as necessary
- flush mounting box and frame
  - for 1-modules: box (9155014, 01284-001) frame (9155011/9155011B, 01278-001/01279-001)
  - for 2-modules: box (9155015, 01285-001), frame (9155012/9155012B, 01280-001/01281-001)
  - for 3-modules: box (9155016, 01286-001), frame(9155013/9155013B, 01282-001/01283-001)



**NOTE**

The one-module frame is designed for stand-alone installations of extending modules such as OUT readers, etc. A 2-module frame is required for the main unit installation.

To install a device **2N LTE Verso** into a wall, mount the flush mounting box first. Then install the device into it.

**1-Module Installation**

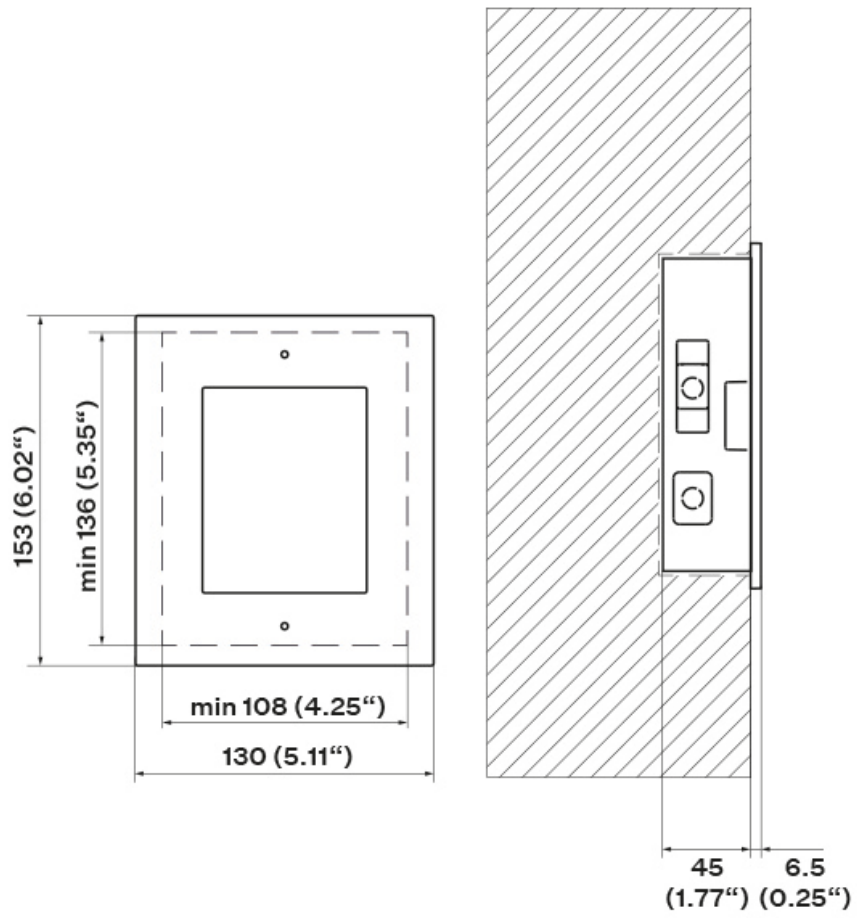

**Box Installation**

**1x**

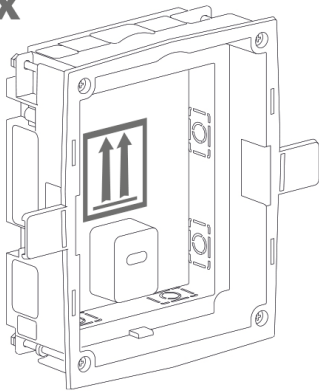

**1.**

min 108(W) x 136(H) x 45(D) mm  
min 4.25(W) x 5.35(H) x 1.77(D) in

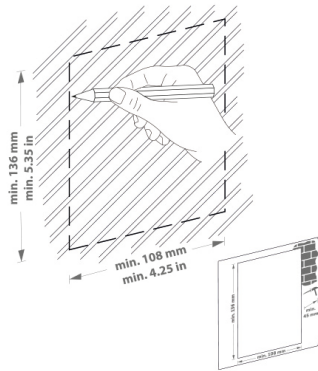

## Installation

2.

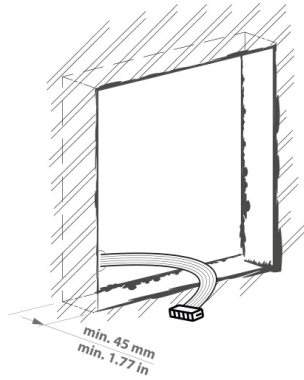

3.

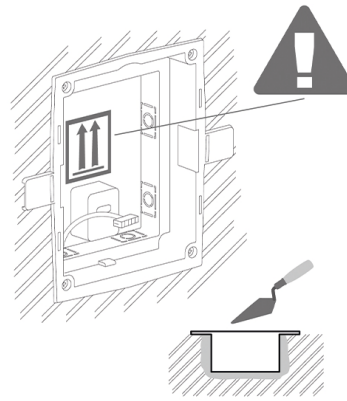

4.

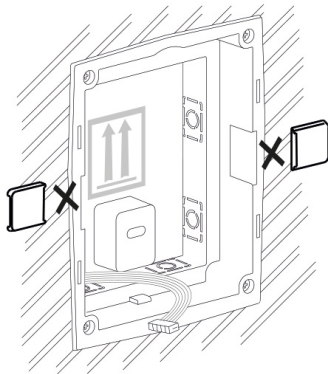

5.

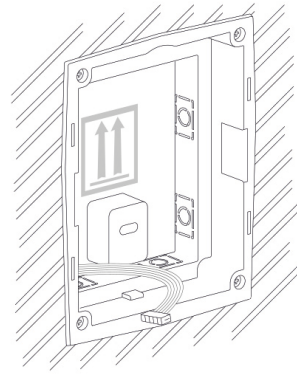

### WARNING

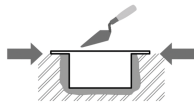

Make sure that the flush mounting box edges are not aligned with the wall but overlap the wall surface. When the proper box installation instructions are not met, water might get in and destroy the device installed. Side stops are used for a correct wall position.



### CAUTION

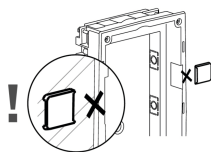

When the walling material has hardened, break off the side stops.

### 1-Module Installation into Box

1.

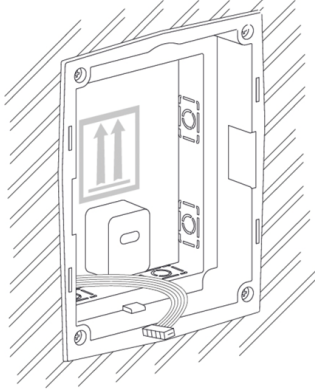

2.

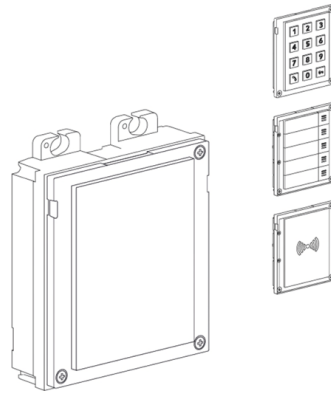

3.

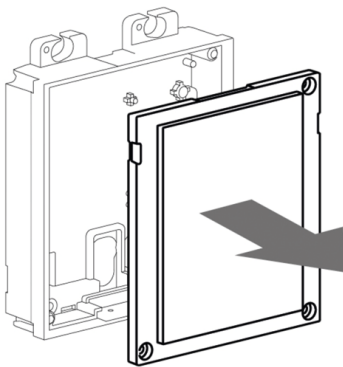

4.

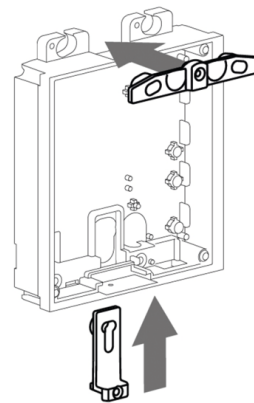

5.

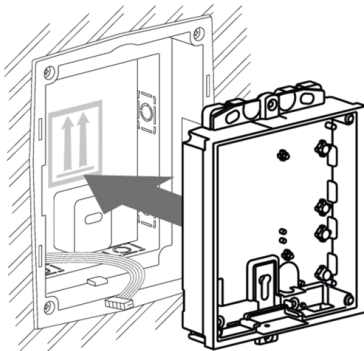

6.

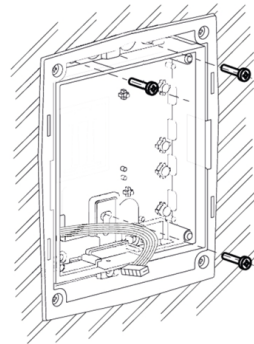

## Installation

7.

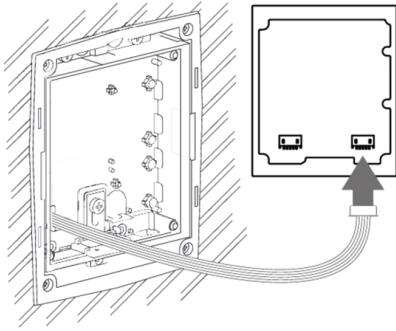

8.

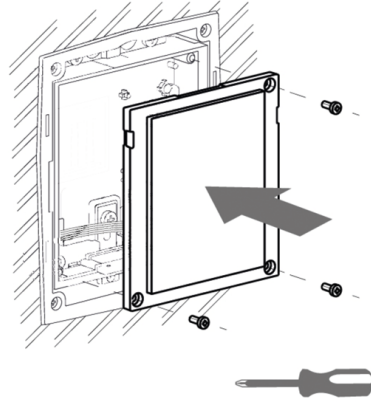

9.

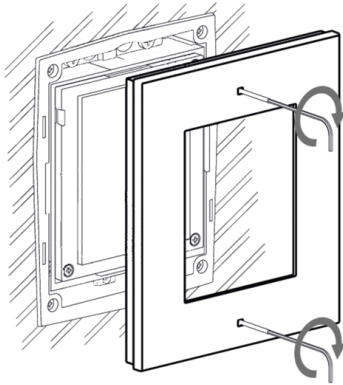

10.

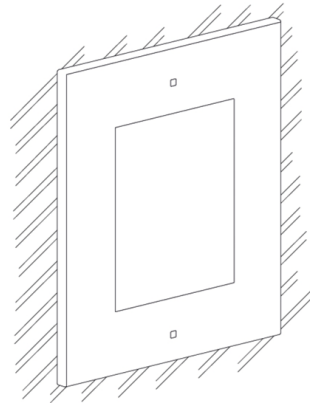

## 2-Module Installation

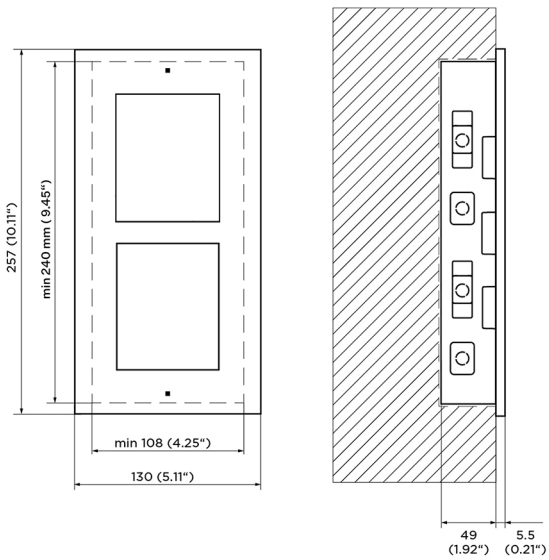

Box Installation

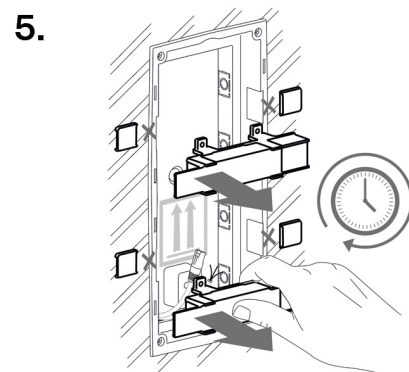
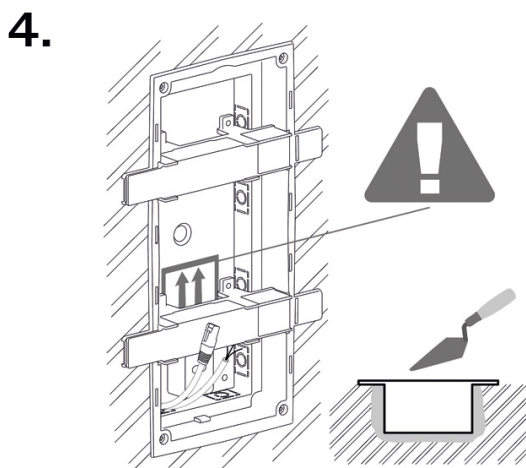
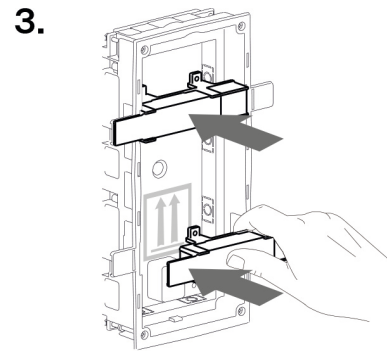
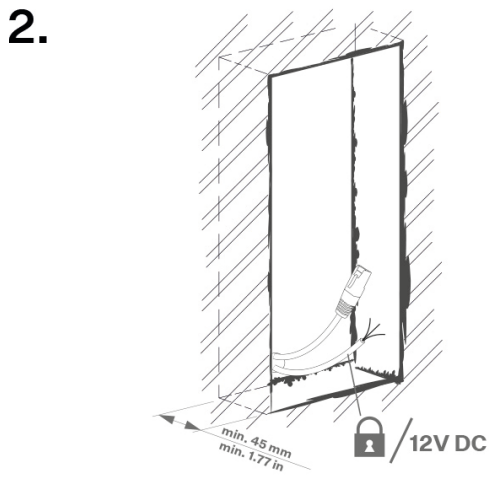
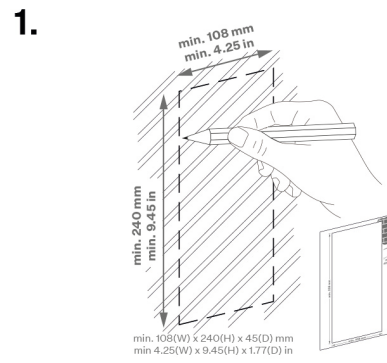
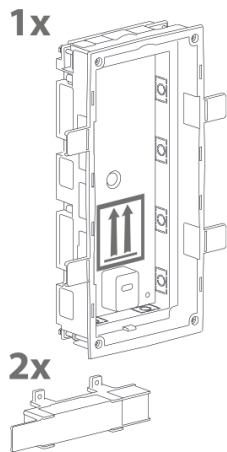

6.

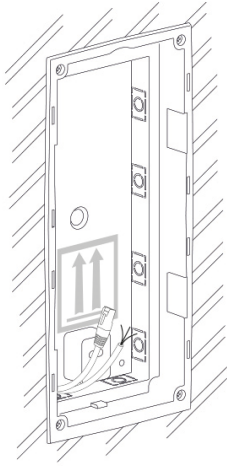

**WARNING**

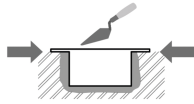

Make sure that the flush mounting box edges are not aligned with the wall but overlap the wall surface. When the proper box installation instructions are not met, water might get in and destroy the device installed. Side stops are used for a correct wall position.



**CAUTION**

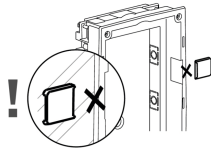

When the walling material has hardened, break off the side stops.

### 2-Module Installation into Box

1.

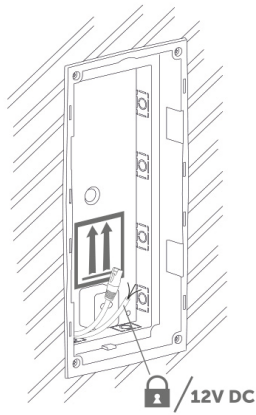

2.

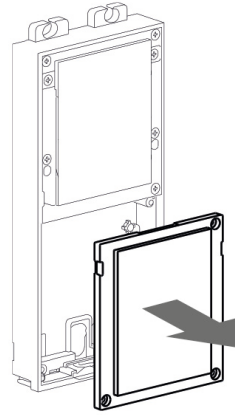

3.

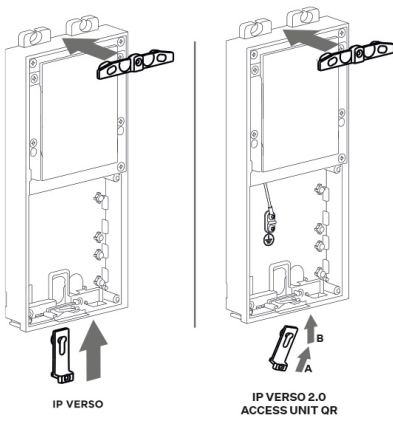

4.

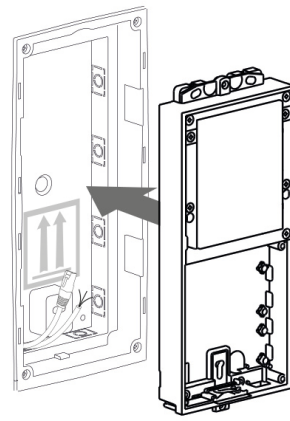

5.

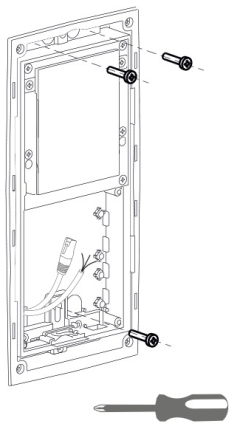

6.

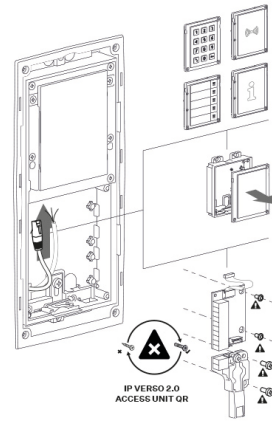

## Installation

7.

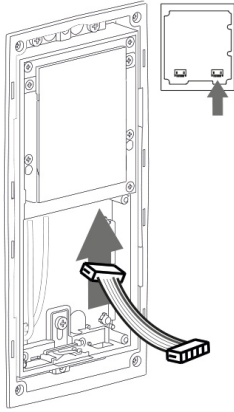

8.

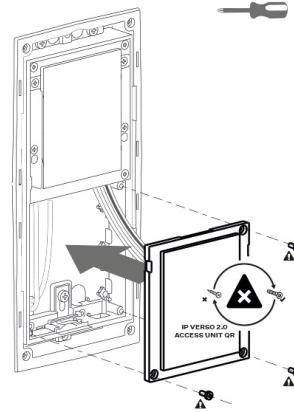

9.

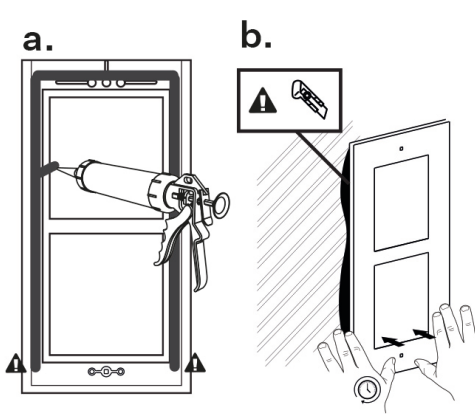

10.

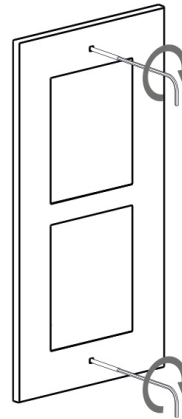

## Installing of Multiple 2-module Boxes Next to Each Other

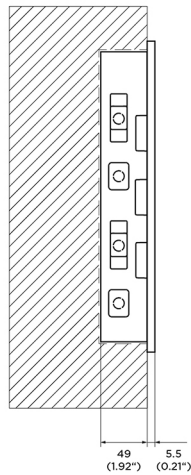
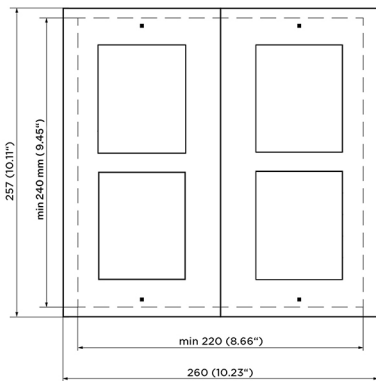

# Installation

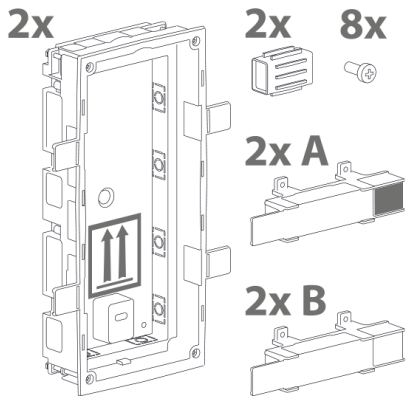

**1.**

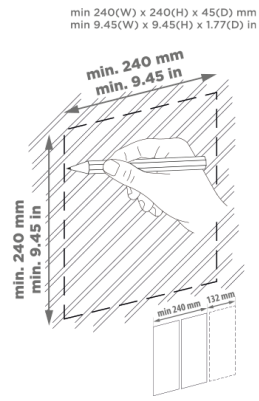

**2.**

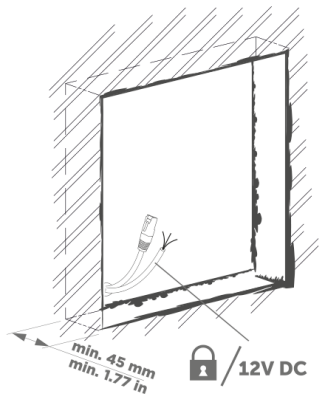

**3.**

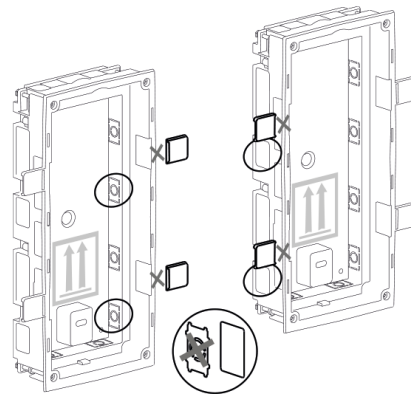

**4.**

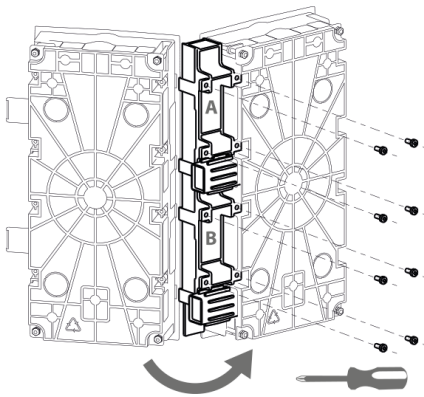

**5.**

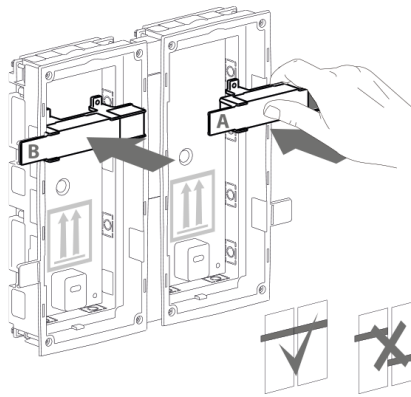

**6.**

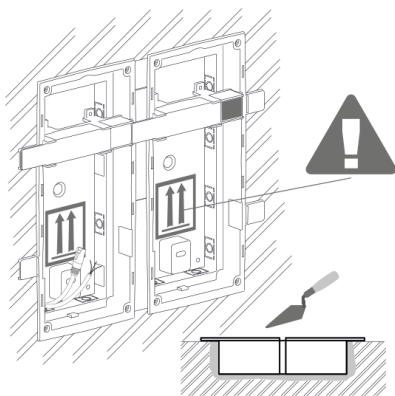

**7.**

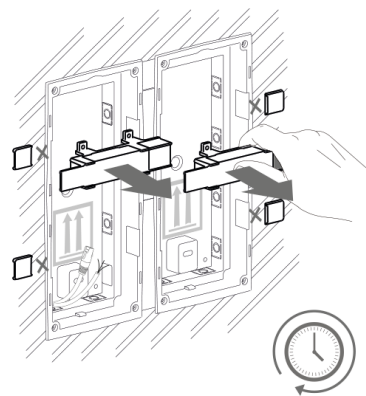



**WARNING**

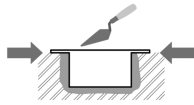

Make sure that the flush mounting box edges are not aligned with the wall but overlap the wall surface. When the proper box installation instructions are not met, water might get in and destroy the device installed. Side stops are used for a correct wall position.



**CAUTION**

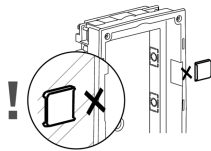

When the walling material has hardened, break off the side stops.

**Installation of Multiple 2-Modules into Box**

1.

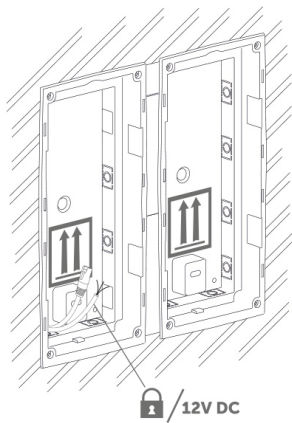

2.

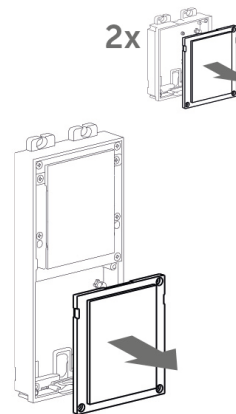

3.

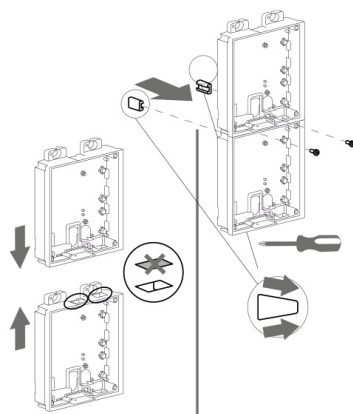

4.

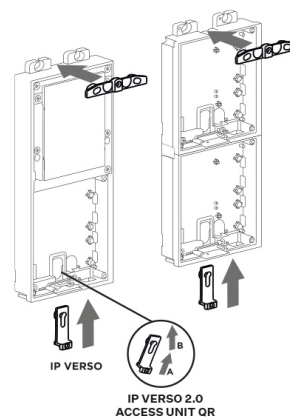

# Installation

5.



6.

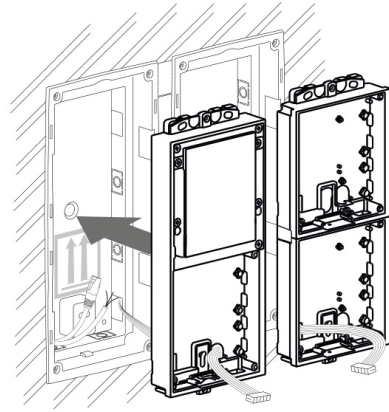

7.

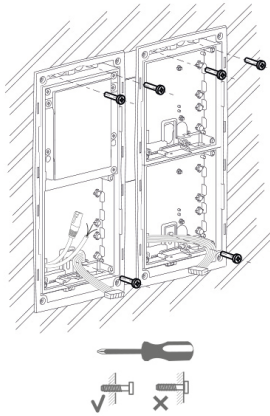

8.

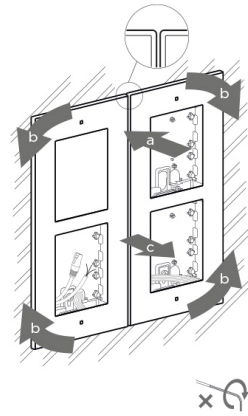

9.

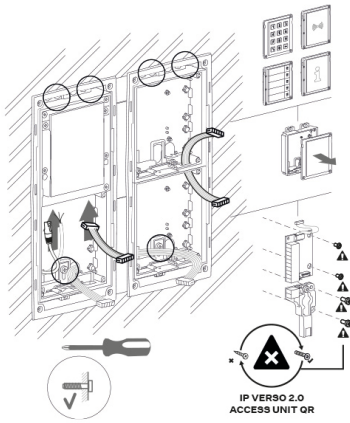

10.

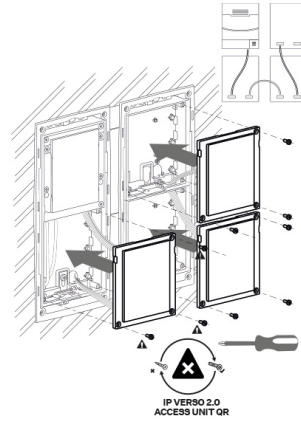

11.

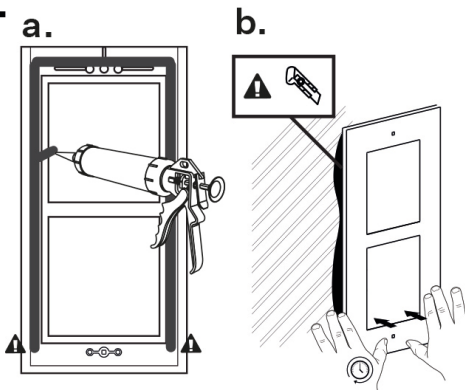

12.

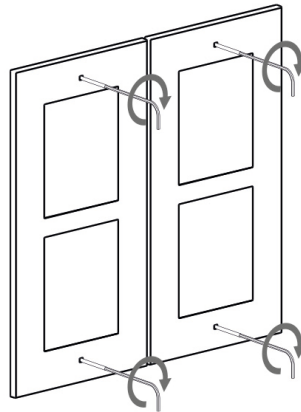

### Frame Attachment

Check the frame sealing before fitting the frame.

Screw the flush mounting frame in the upper and bottom parts.

Hang the surface mounting frame on the hook in the upper part and then screw it tight in the bottom part.

### 3-Module Installation

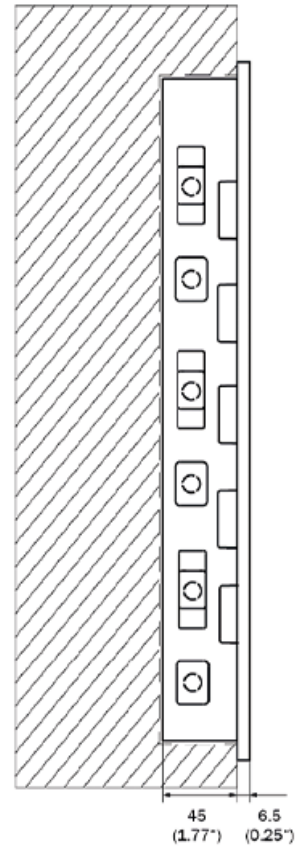
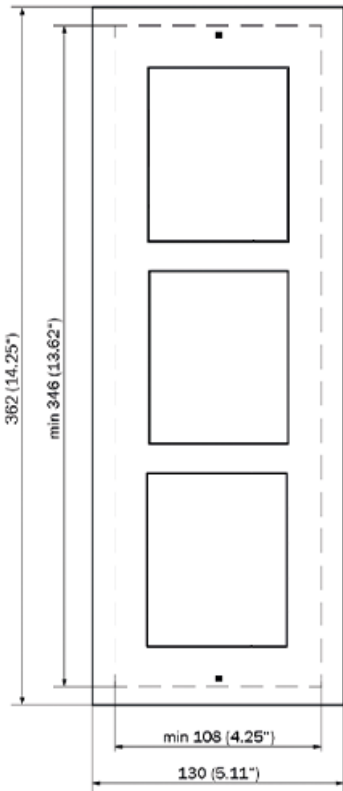

### Box Installation

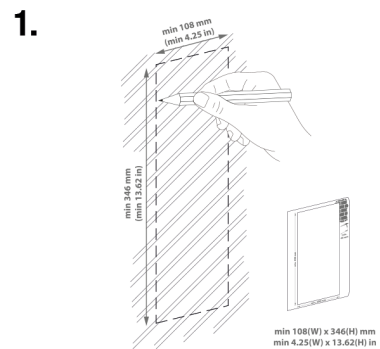
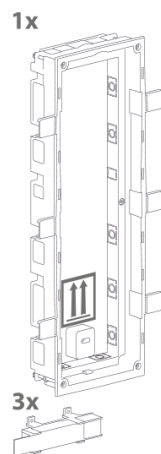

# Installation

2.

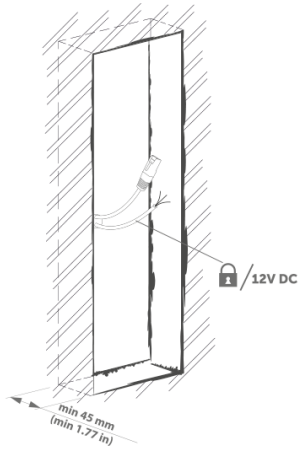

3.

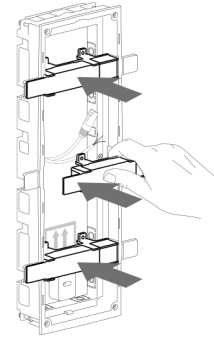

4.

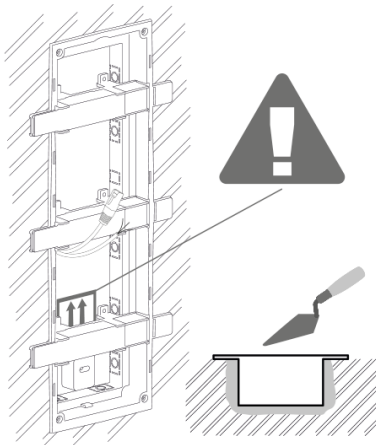

5.

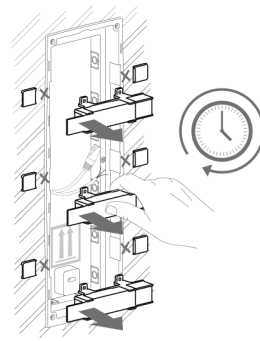

6.

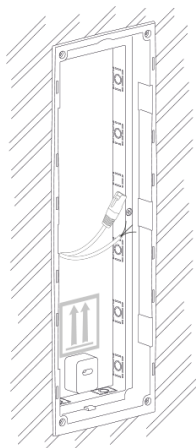



**WARNING**

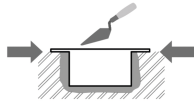

Make sure that the flush mounting box edges are not aligned with the wall but overlap the wall surface. When the proper box installation instructions are not met, water might get in and destroy the device installed. Side stops are used for a correct wall position.



**CAUTION**

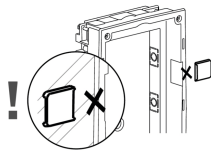

When the walling material has hardened, break off the side stops.

**Installation of Multiple 3-Module Boxes Next to Each Other**

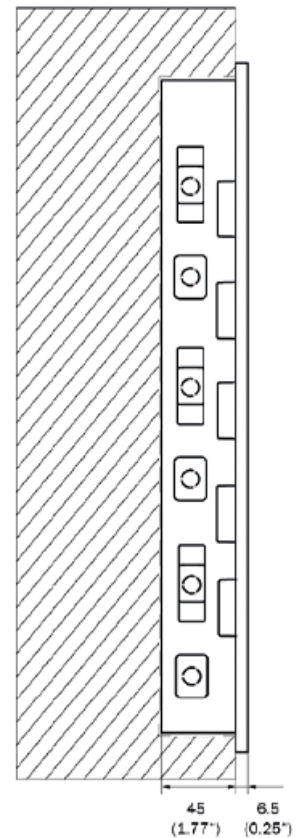
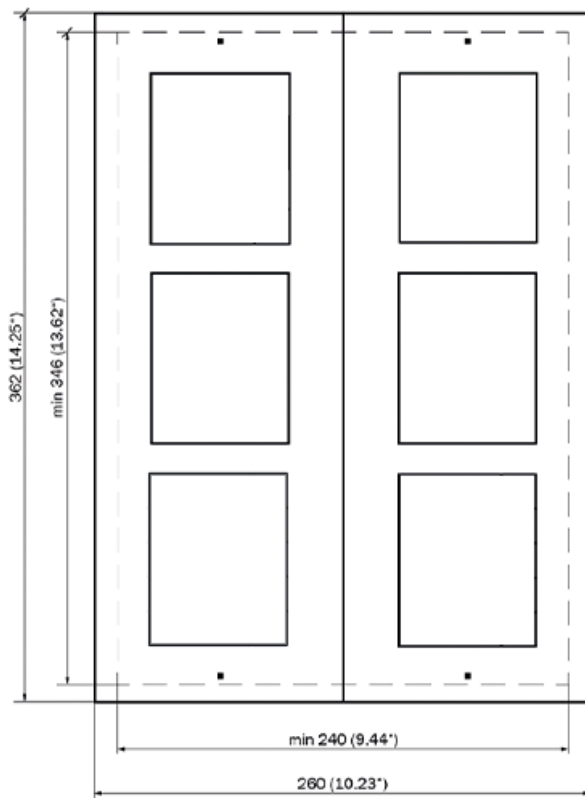

# Installation

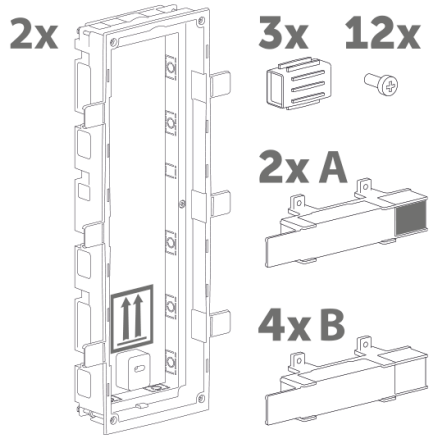

**1.**

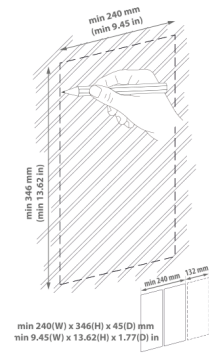

**2.**

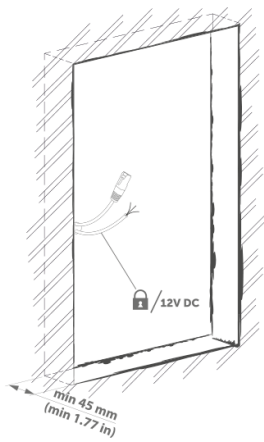

**3.**

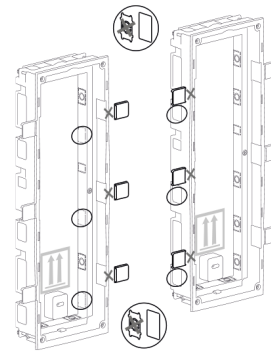

**4.**

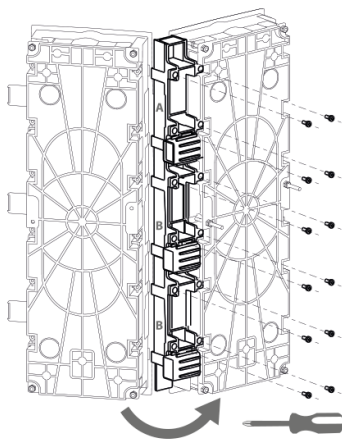

**5.**

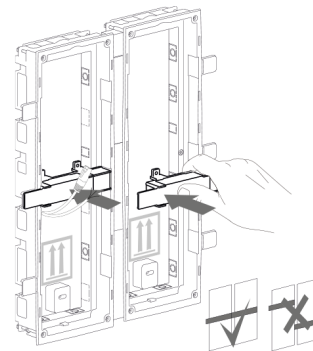

6.

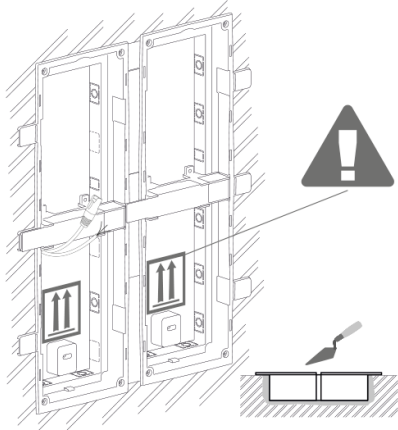

7.

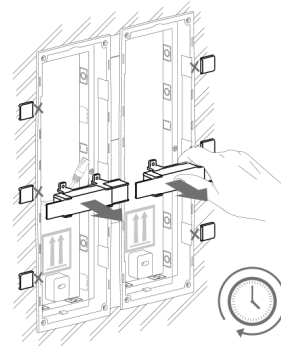

8.

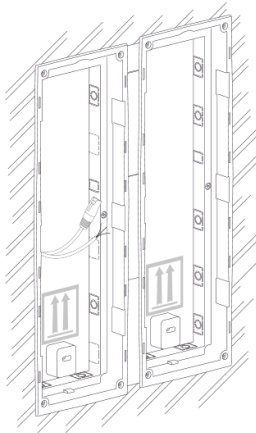

**WARNING**



Make sure that the flush mounting box edges are not aligned with the wall but overlap the wall surface. When the proper box installation instructions are not met, water might get in and destroy the device installed. Side stops are used for a correct wall position.



**CAUTION**

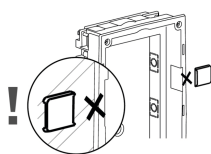

When the walling material has hardened, break off the side stops.

### 3-Module Installation into Box

1.

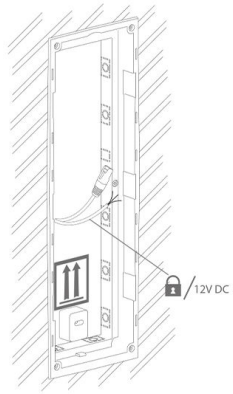

2.

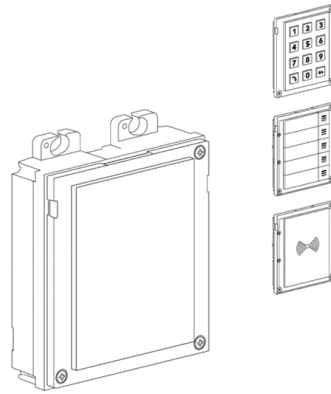

3.

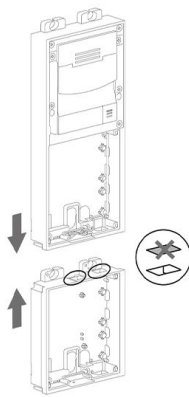

4.

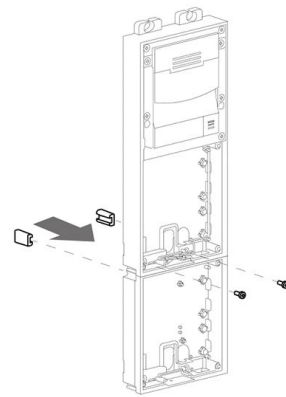

5.

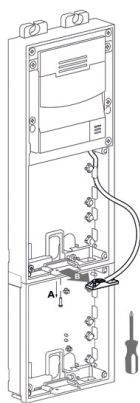

6.

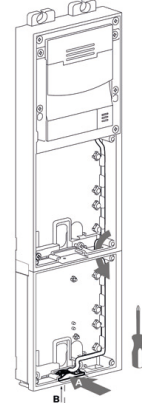

## Installation

7.

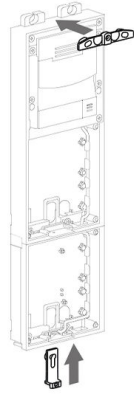

8.

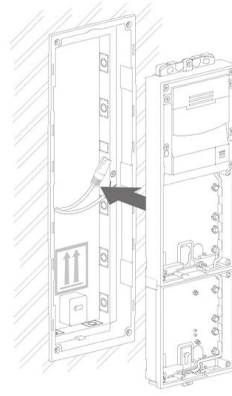

9.

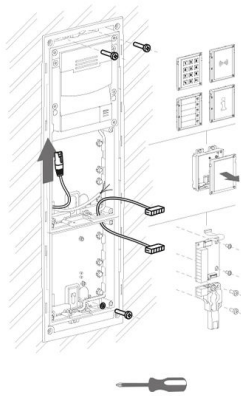

10.

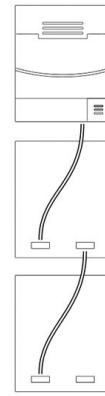

11.

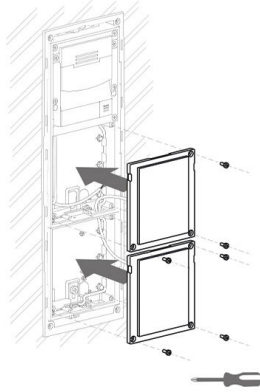

12.



### Frame Attachment

Check the frame sealing before fitting the frame.

Screw the flush mounting frame in the upper and bottom parts.

Hang the surface mounting frame on the hook in the upper part and then screw it tight in the bottom part.

## Flush mounting – into plasterboard

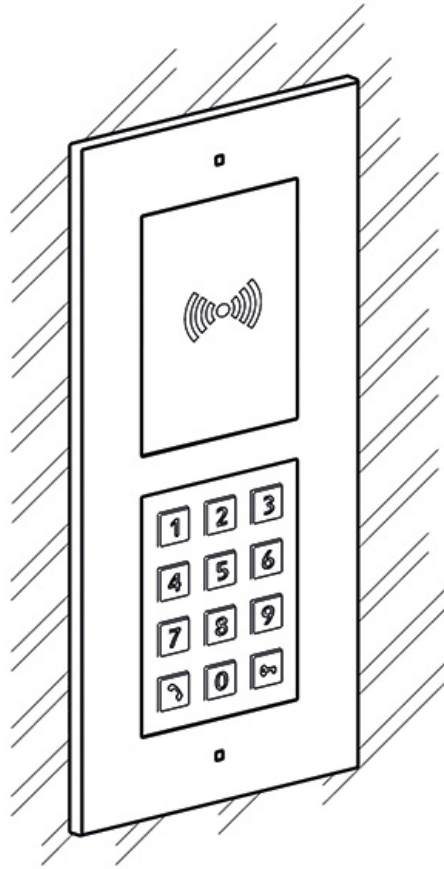

What you need for mounting:

- **2N LTE Verso**
- a properly cut hole as instructed in the box package
- flush mounting box and frame
  - for 1-modules: box (9155014, 01284-001) frame (9155011/9155011B, 01278-001/01279-001)
  - for 2-modules: box (9155015, 01285-001), frame (9155012/9155012B, 01280-001/01281-001)
  - for 3-modules: box (9155016, 01286-001), frame(9155013/9155013B, 01282-001/01283-001)



### NOTE

The one-module frame is designed for stand-alone installations of extending modules such as OUT readers, etc. A 2-module frame is required for the main unit installation.

To install a device **2N LTE Verso** into a wall, mount the flush mounting box first. Then install the device into it.

### 2-Module Installation

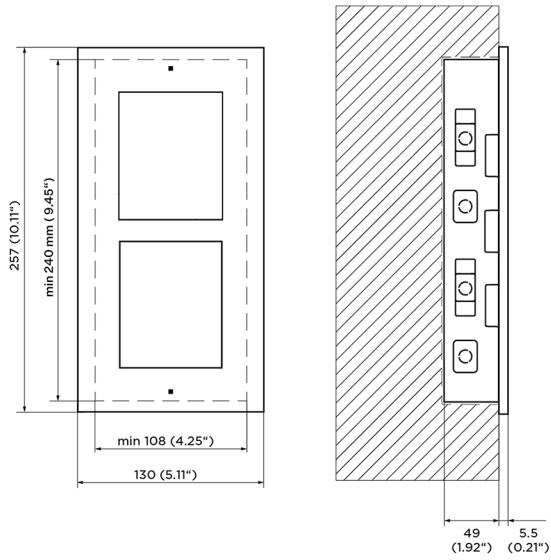

### Box Installation

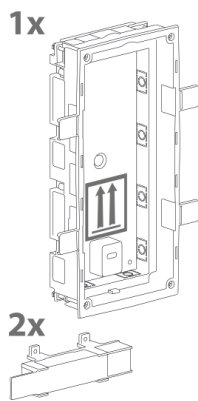

1.

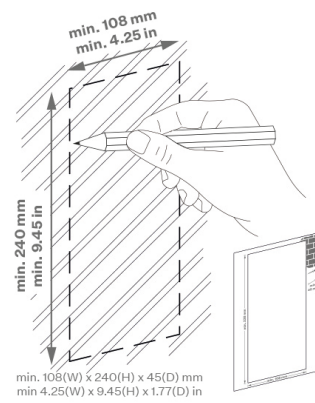

2.

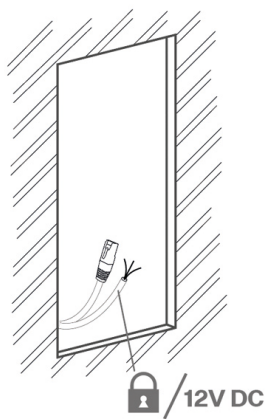

3.

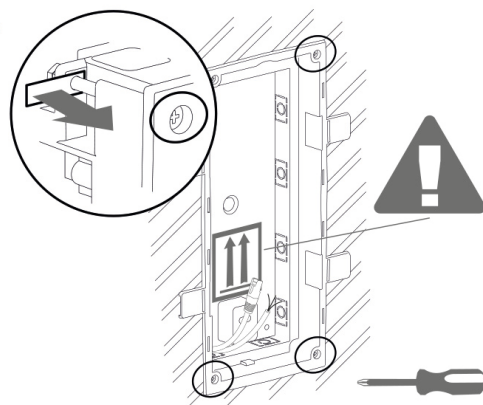

## Installation

4.

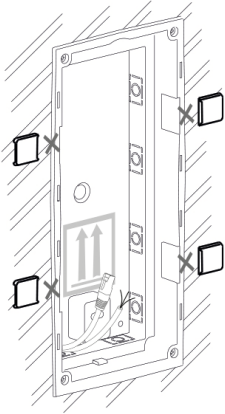

5.



### WARNING

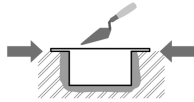

Make sure that the flush mounting box edges are not aligned with the wall but overlap the wall surface. When the proper box installation instructions are not met, water might get in and destroy the device installed. Side stops are used for a correct wall position.



### CAUTION

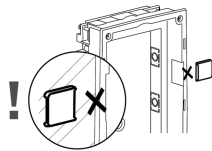

When the walling material has hardened, break off the side stops.

### 2-Module Installation into Box

1.

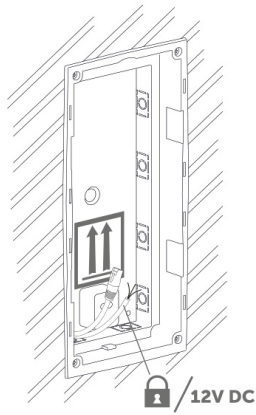

2.

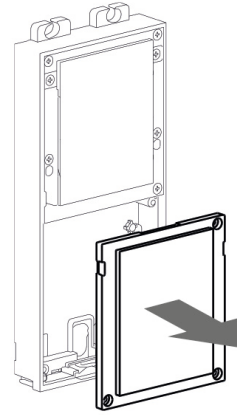

3.

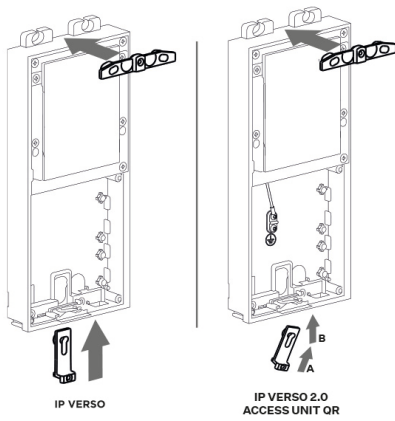

4.

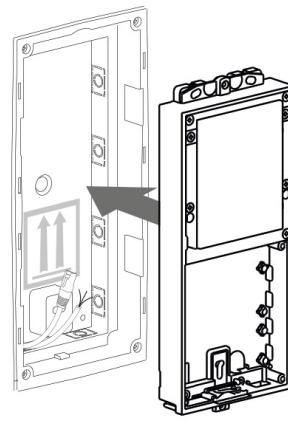

5.

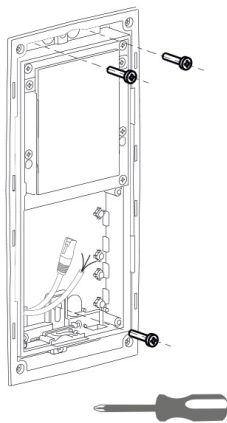

6.

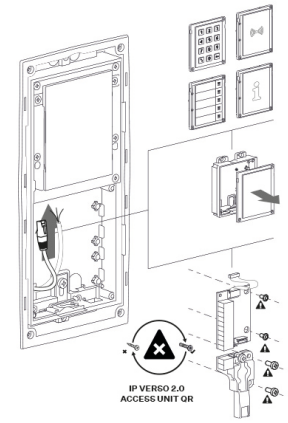

## Installation

7.

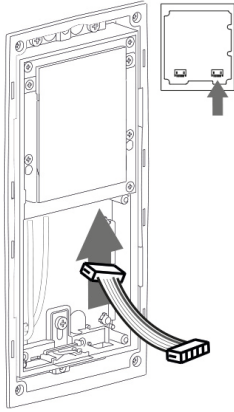

8.

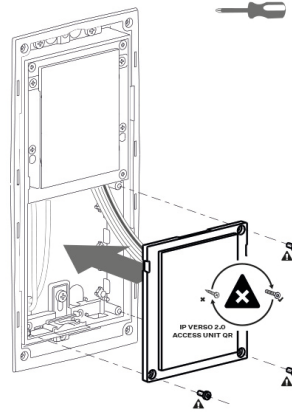

9.

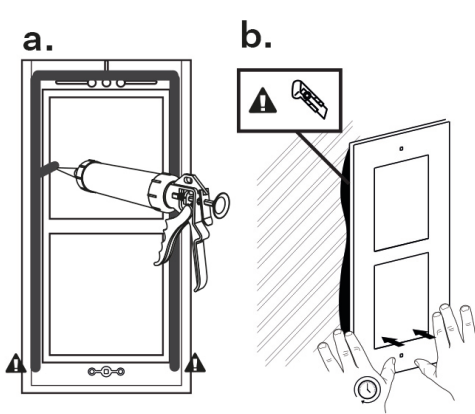

10.

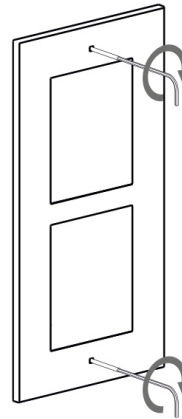

### Frame Attachment

Check the frame sealing before fitting the frame.

Screw the flush mounting frame in the upper and bottom parts.

Hang the surface mounting frame on the hook in the upper part and then screw it tight in the bottom part.

### Installation of Multiple 2-Module Boxes Next to Each Other

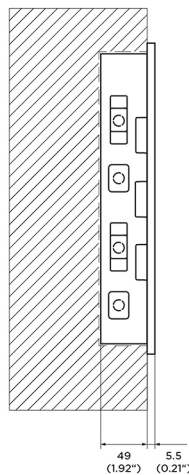
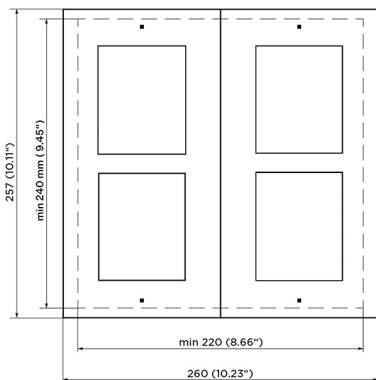

# Installation

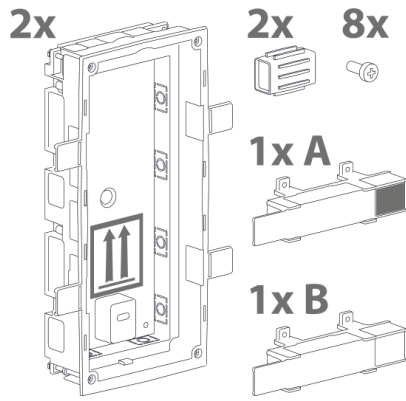

**1.**

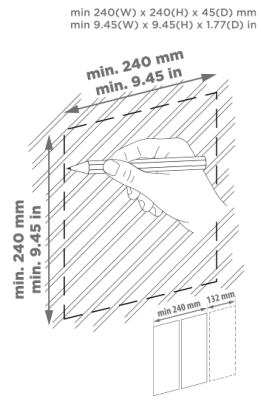

**2.**

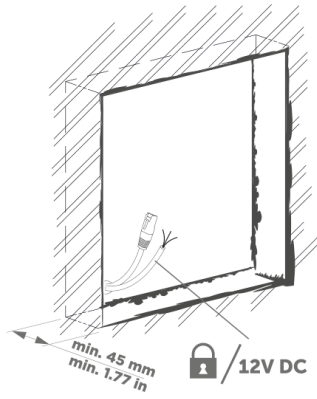

**3.**

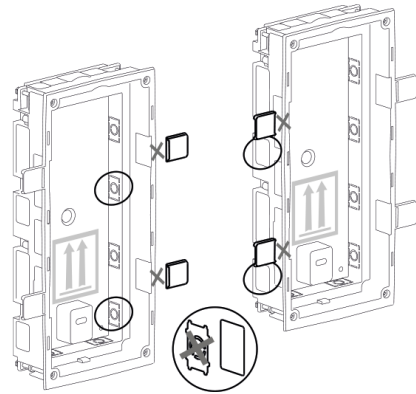

**4.**

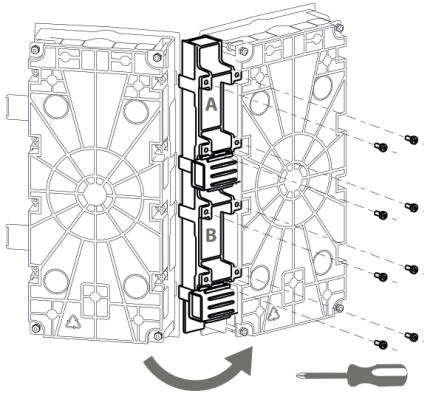

**5.**

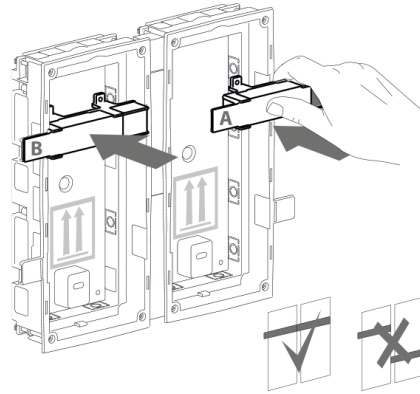

**6.**

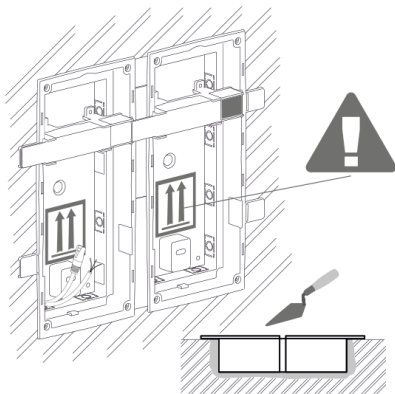

**7.**

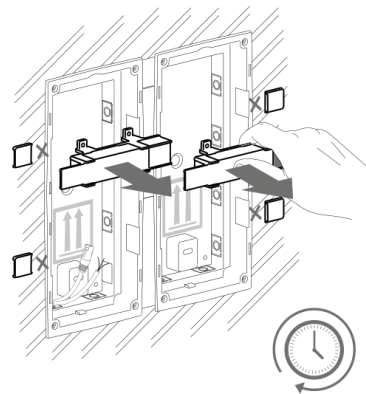



**WARNING**

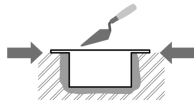

Make sure that the flush mounting box edges are not aligned with the wall but overlap the wall surface. When the proper box installation instructions are not met, water might get in and destroy the device installed. Side stops are used for a correct wall position.



**CAUTION**

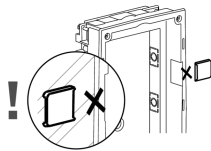

When the walling material has hardened, break off the side stops.

**Installation of Multiple 2-Modules into Box**

1.

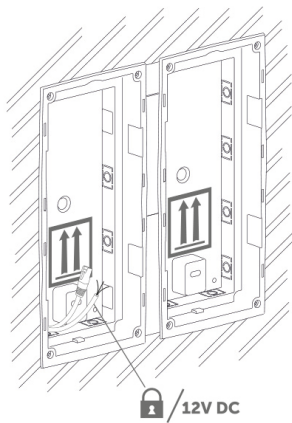

2.

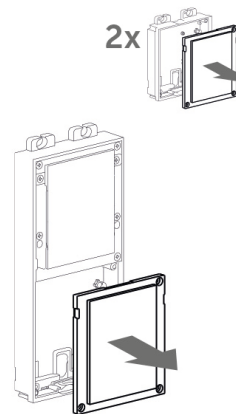

3.

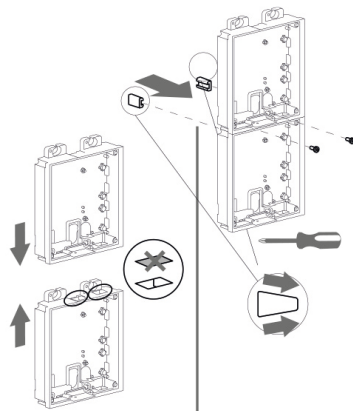

4.

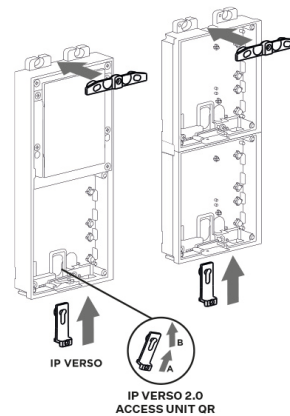

# Installation

5.



6.

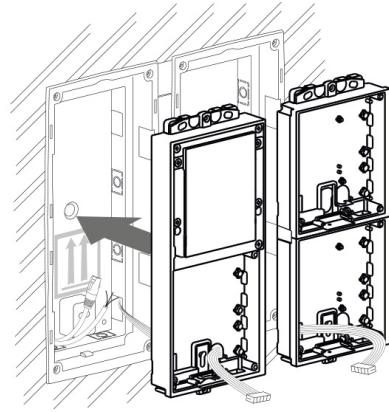

7.

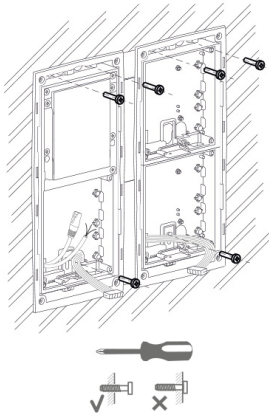

8.

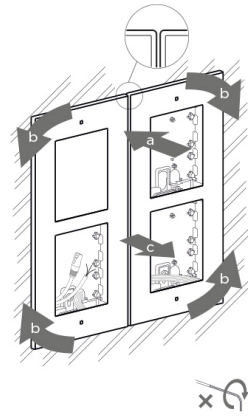

9.

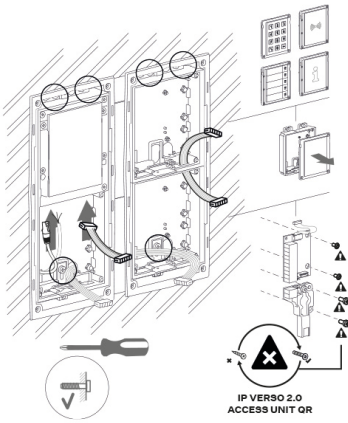

10.

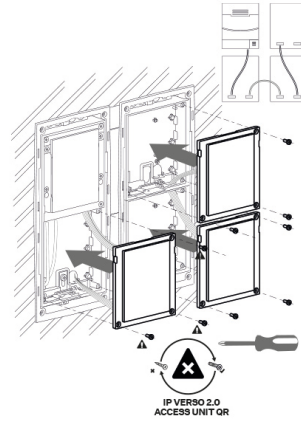

11.

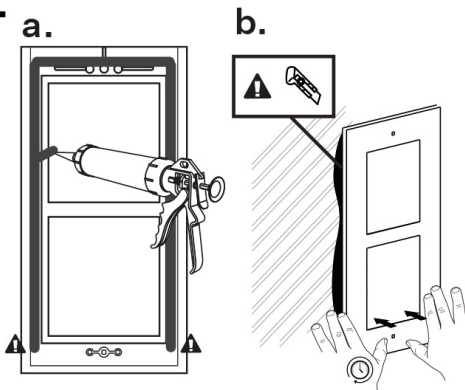

12.

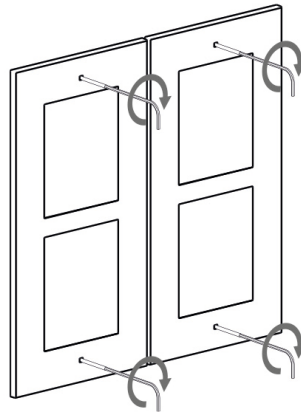

### 3-Module Installation

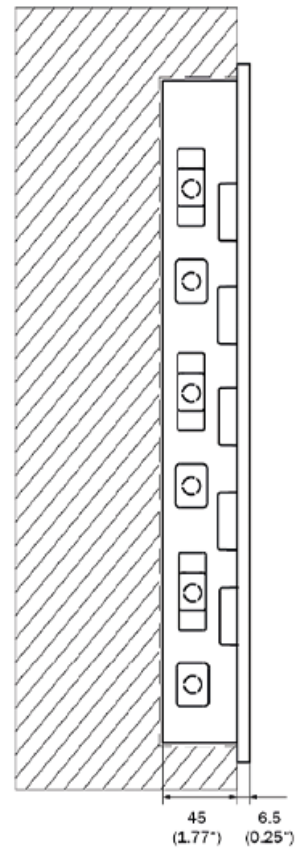
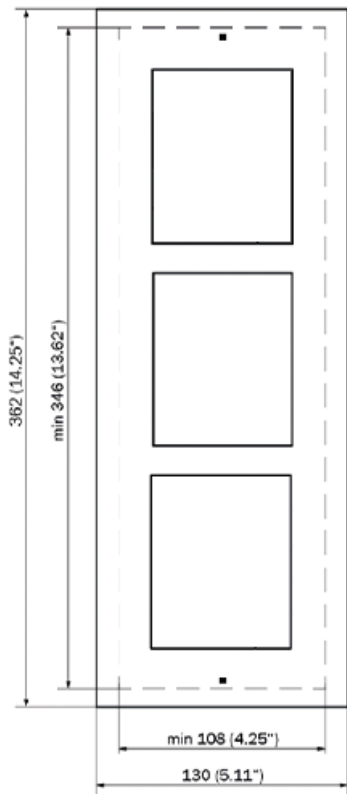

### Box Installation

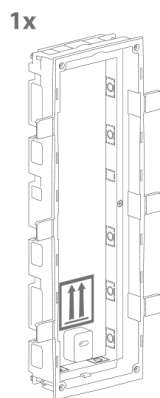

1.

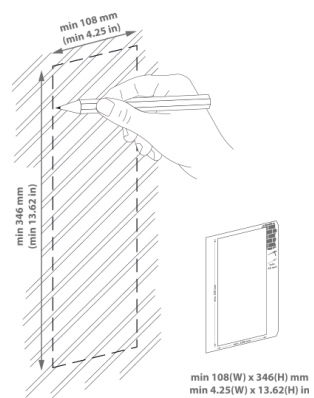

## Installation

2.

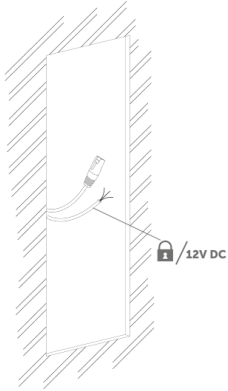

3.

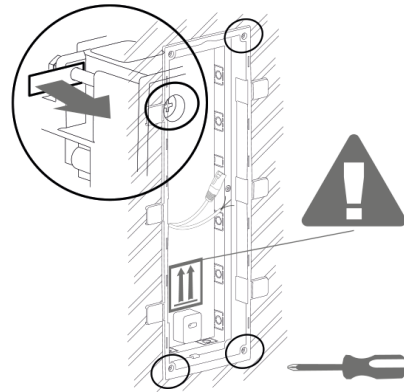

4.

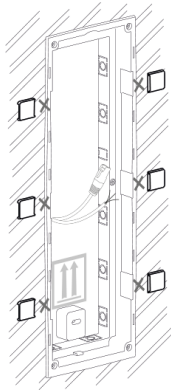

5.

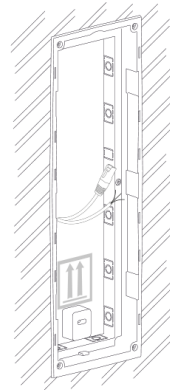

### WARNING

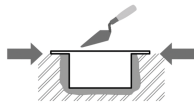

Make sure that the flush mounting box edges are not aligned with the wall but overlap the wall surface. When the proper box installation instructions are not met, water might get in and destroy the device installed. Side stops are used for a correct wall position.



### CAUTION

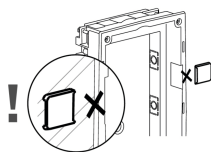

When the walling material has hardened, break off the side stops.

**Installation of Multiple 3-Module Boxes Next to Each Other**

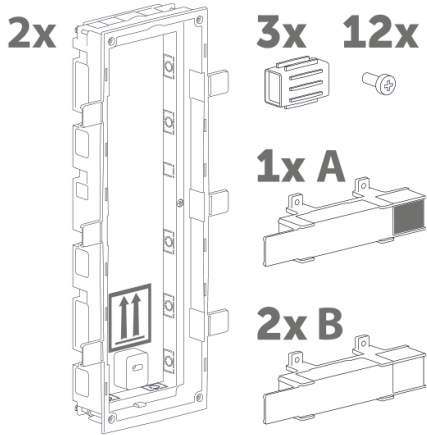
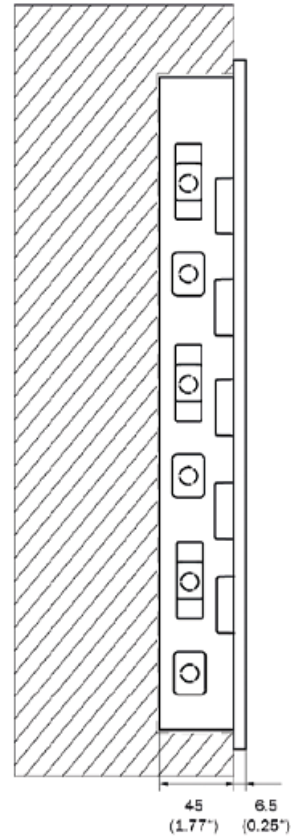
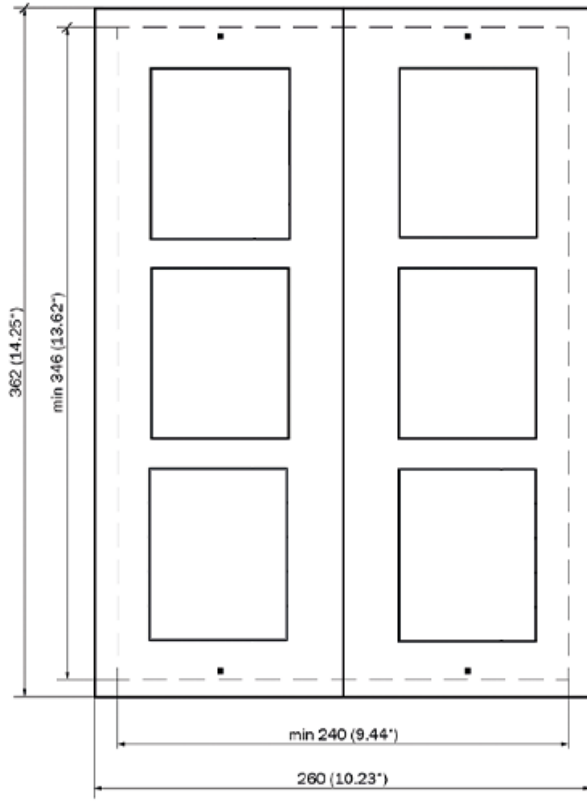

**1.**

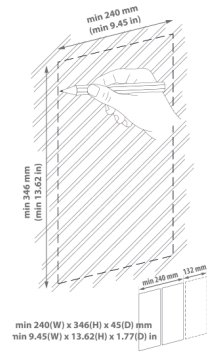

# Installation

2.

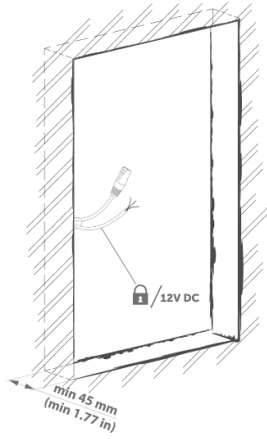

3.

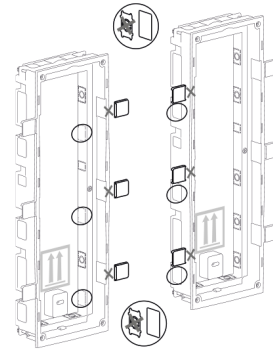

4.

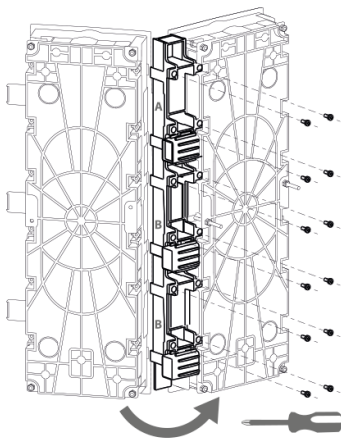

5.

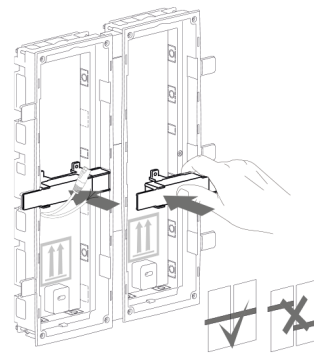

6.

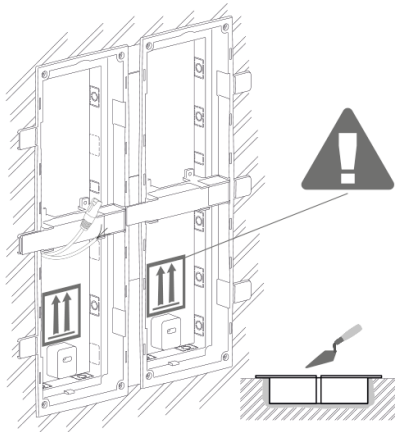

7.

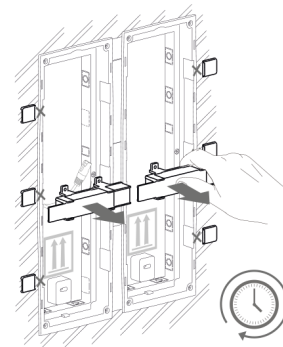

8.

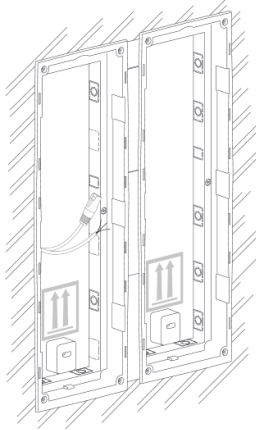

**WARNING**

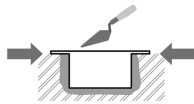

Make sure that the flush mounting box edges are not aligned with the wall but overlap the wall surface. When the proper box installation instructions are not met, water might get in and destroy the device installed. Side stops are used for a correct wall position.



**CAUTION**

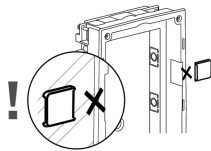

When the walling material has hardened, break off the side stops.

### 3-Module Installation into Box

1.

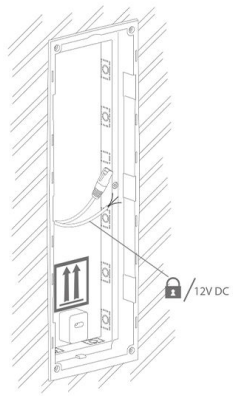

2.

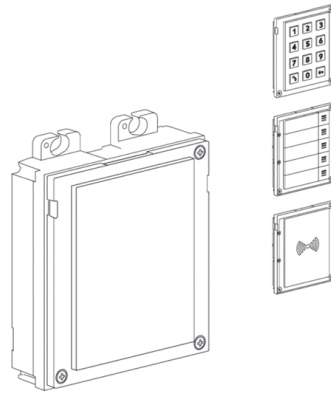

3.

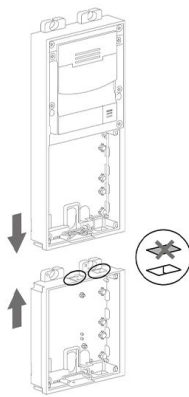

4.

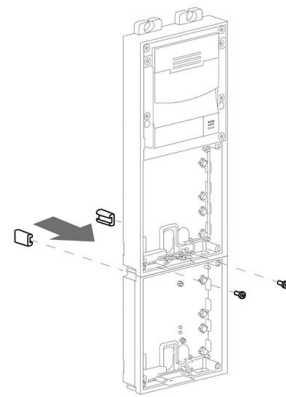

5.

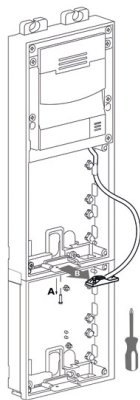

6.

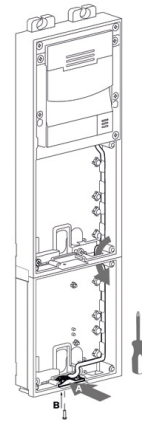

## Installation

7.

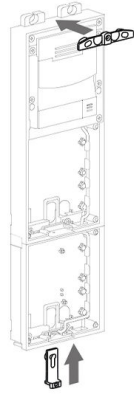

8.

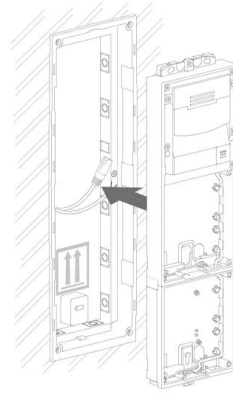

9.

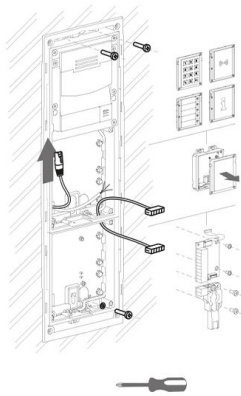

10.

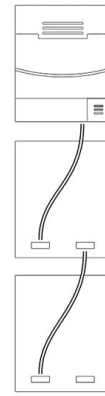

11.

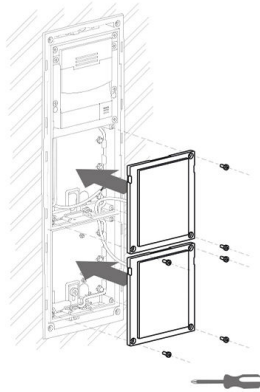

12.



### Frame Attachment

Check the frame sealing before fitting the frame.

Screw the flush mounting frame in the upper and bottom parts.

Hang the surface mounting frame on the hook in the upper part and then screw it tight in the bottom part.

**1-Module Installation**

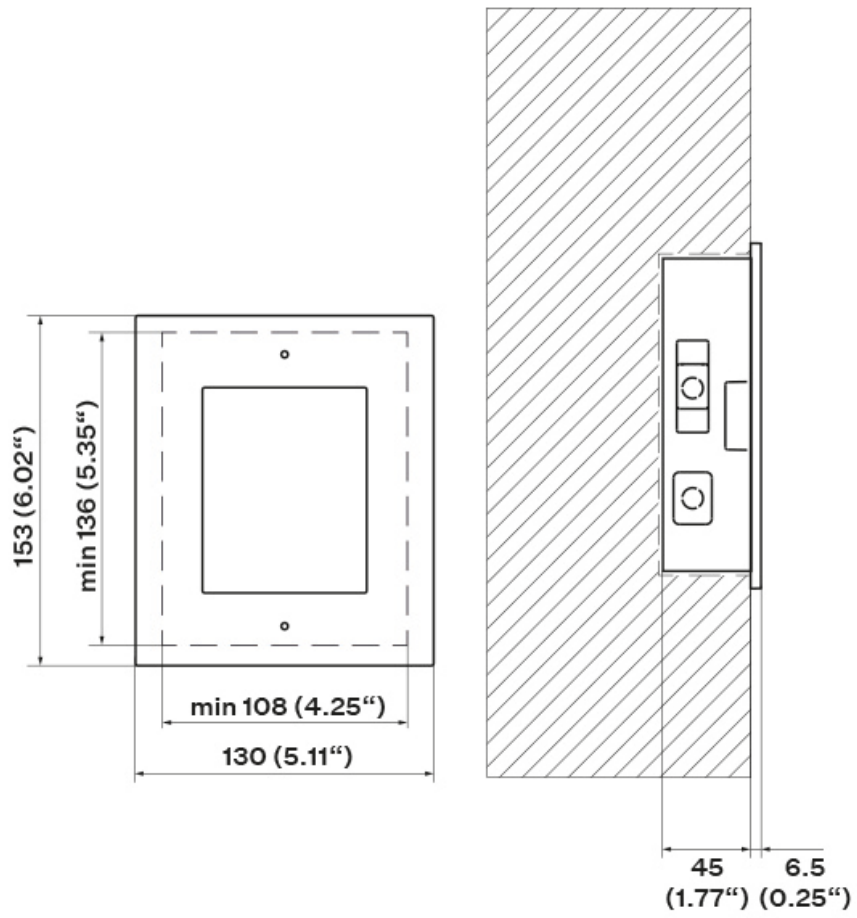

**Box Installation**

**1x**

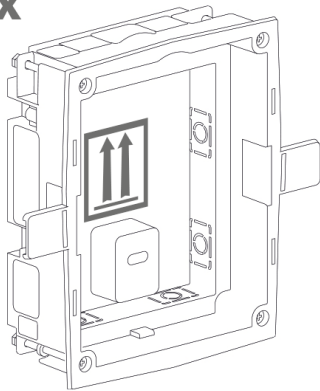

**1.**

min 108(W) x 136(H) x 45(D) mm  
min 4.25(W) x 5.35(H) x 1.77(D) in

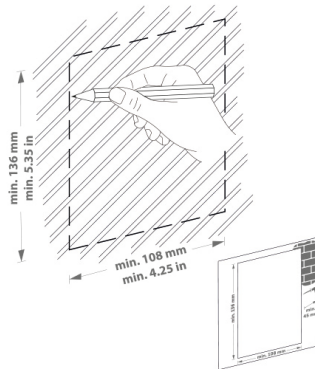

## Installation

2.

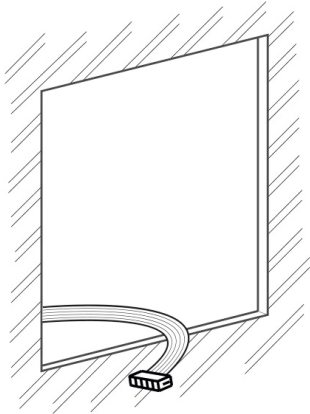

3.

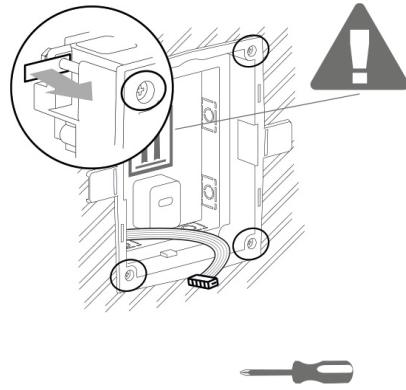

4.

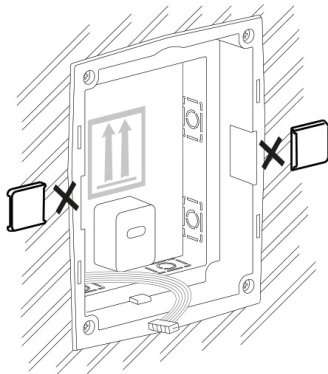

5.

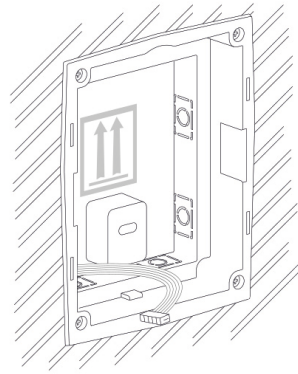

### WARNING

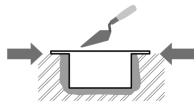

Make sure that the flush mounting box edges are not aligned with the wall but overlap the wall surface. When the proper box installation instructions are not met, water might get in and destroy the device installed. Side stops are used for a correct wall position.



### CAUTION

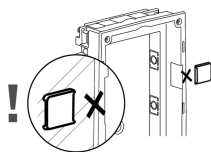

When the walling material has hardened, break off the side stops.

### 1-Module Installation into Box

1.

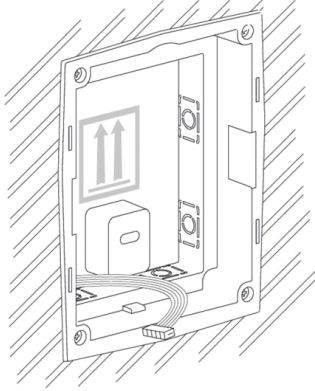

2.

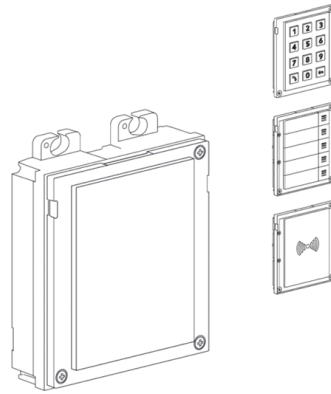

3.

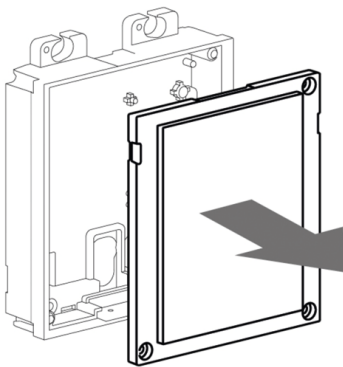

4.

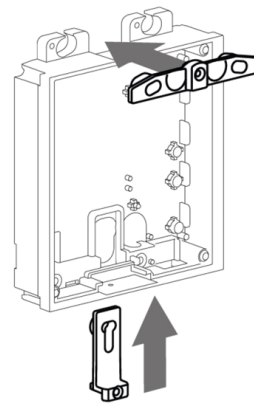

5.

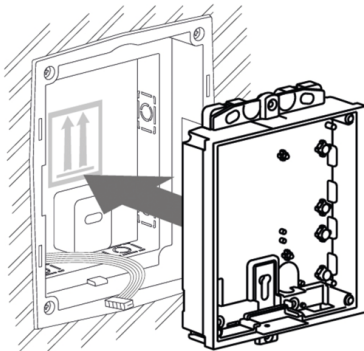

6.

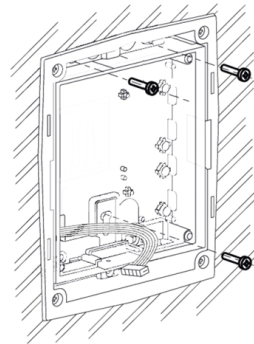

7.

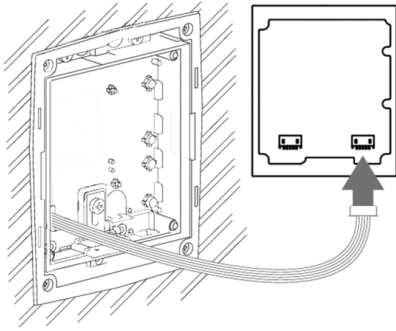

8.

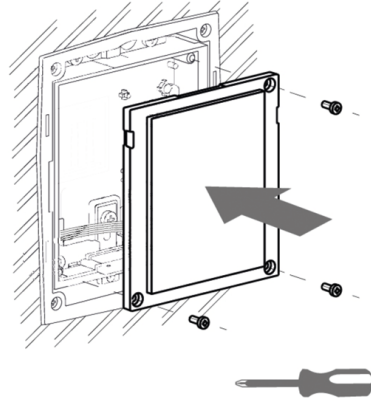

9.

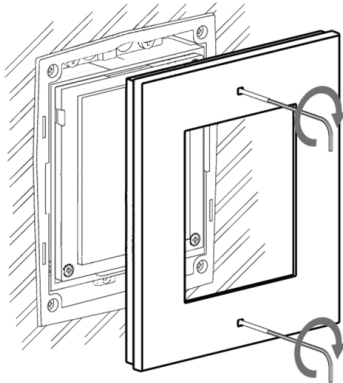

10.

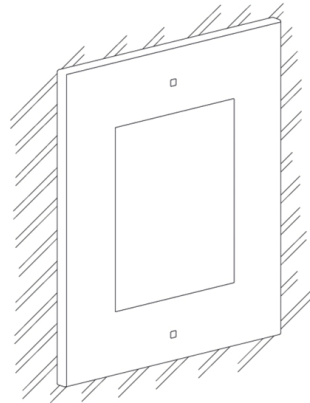

### Frame Attachment

Check the frame sealing before fitting the frame.

Screw the flush mounting frame in the upper and bottom parts.

Hang the surface mounting frame on the hook in the upper part and then screw it tight in the bottom part.

### Surface Installation

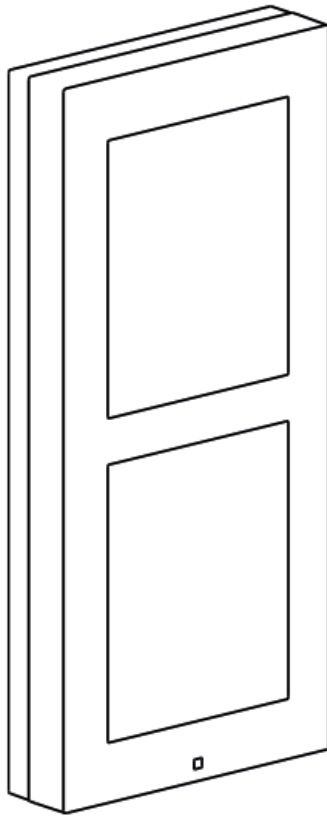

What you need for mounting:

- **2N LTE Verso**
- drilling template
- a proper frame
  - for 1-modules: frame (9155021/9155021B, 01287-001/01288-001)
  - for 2-modules: frame (9155022/9155022B, 01289-001/01290-001)
  - for 3-modules: frame (9155023/9155023B, 01291-001/01292-001)



### NOTE

The one-module frame is designed for stand-alone installations of extending modules such as OUT readers, etc. A 2-module frame is required for the main unit installation.

For uneven surfaces, use a backplate for the required count of modules (9155061/9155062, 01293-001/01294-001).



### DANGER

Eliminate the risk of personal injury! Surface installation is not recommended for narrow passages or places where people's attention is distracted by something else. The manufacturer shall not be liable for injuries in such cases!



**WARNING**

- Make sure that the installation surface is flat with a maximum inequality of 0.5 mm. (e.g. prefabricated boards, glass, cut stone, etc.). If the installation surface is not even, use the flush mounting type or equalize the wall surface with a backplate (9155061/9155062/9155068, 01293-001/01294-001/01305-001) or make the wall surface perfectly flat.

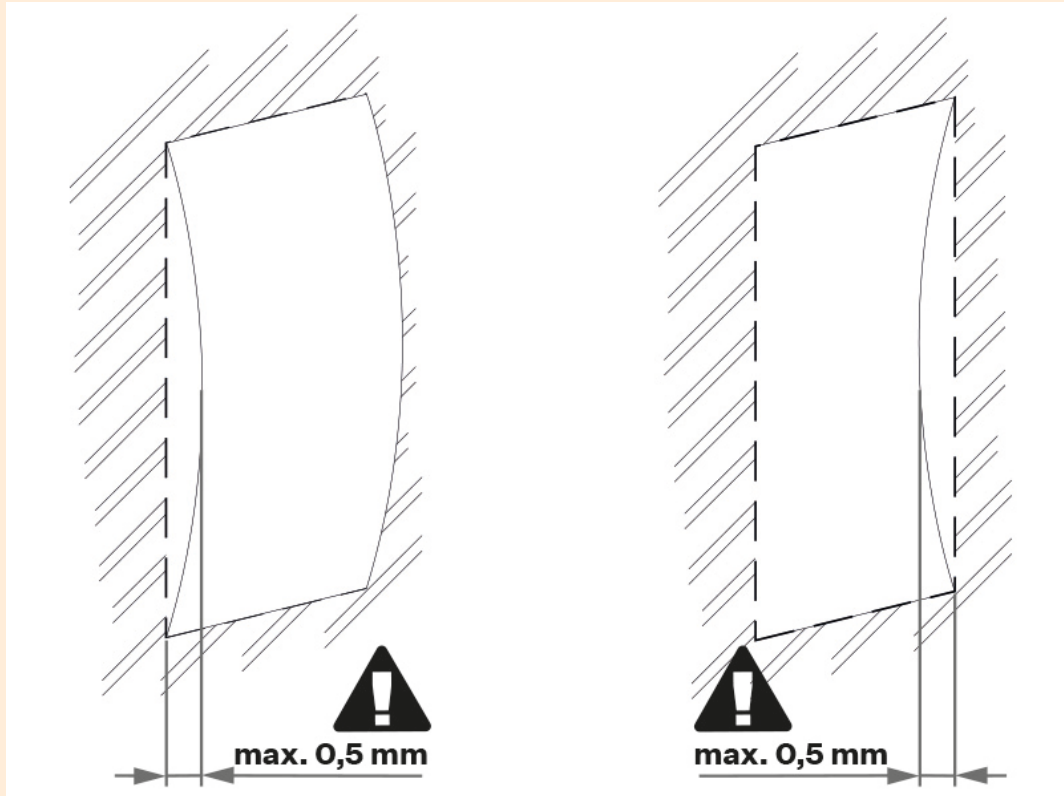

- Surface mounting always poses a problem where the installation is exposed to potential vandalism (such as public garages, etc.). In that case, use steel fixing elements instead of the dowels and screws included in the delivery.

## 2-Module Installation

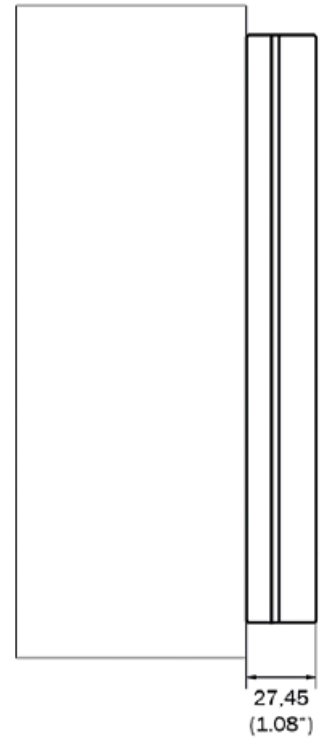
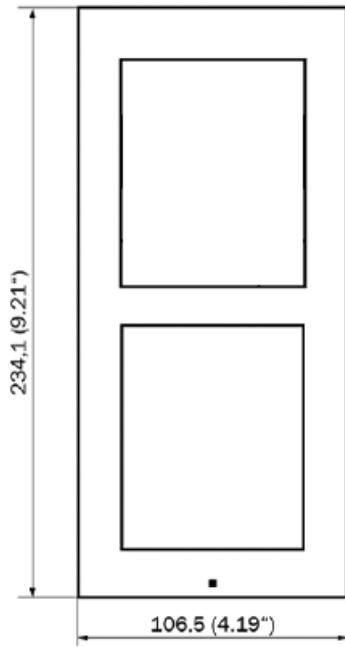

### TIP

Download the [drilling template](#) from 2N.com.

1.

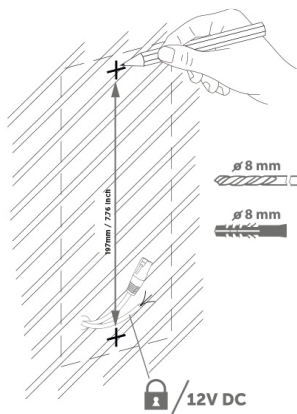

2.

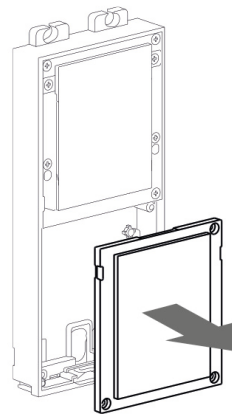

# Installation

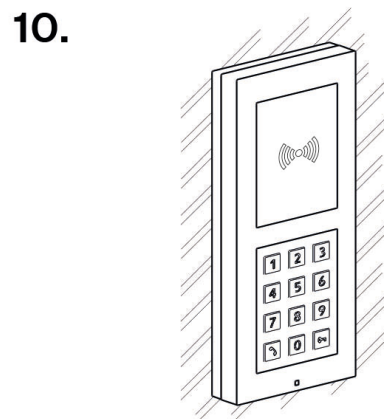
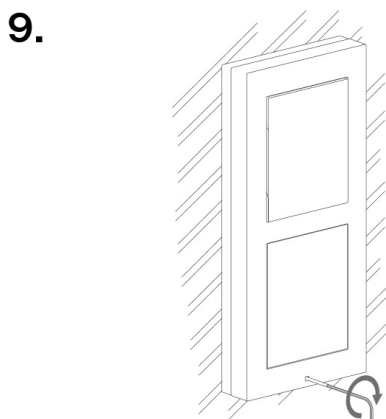
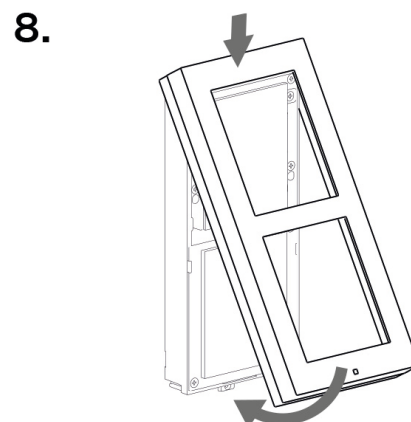
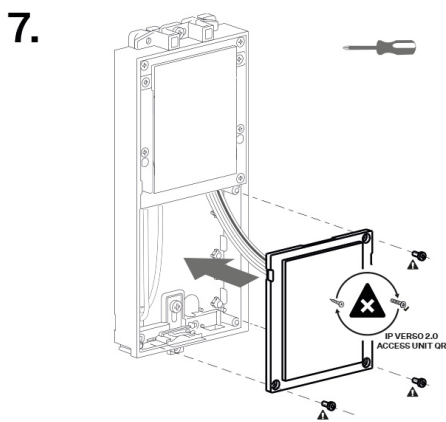
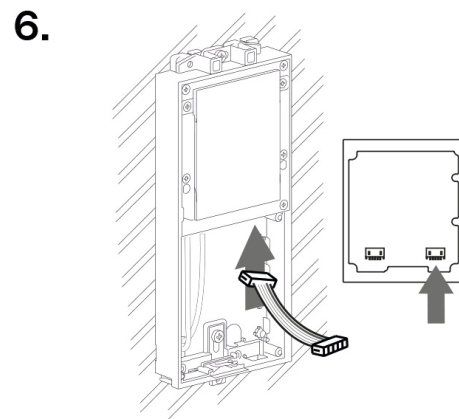
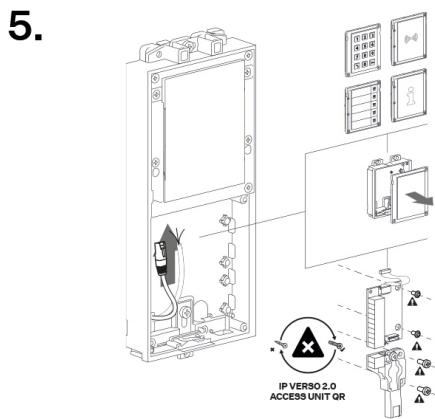
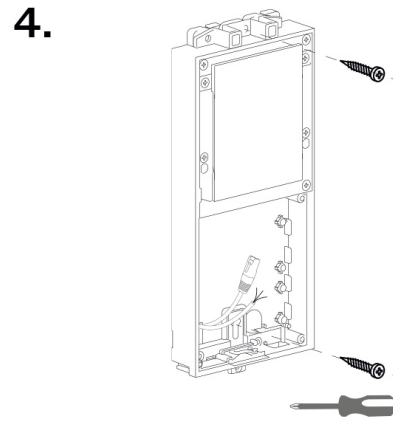
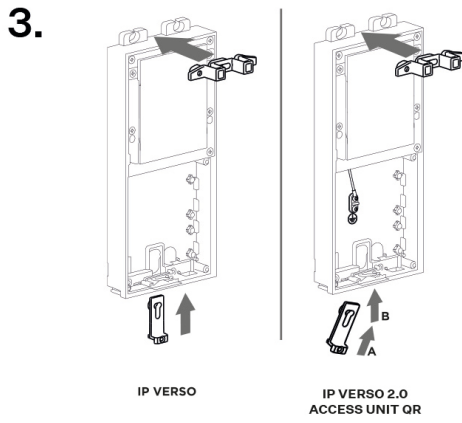

### Frame Attachment

Check the frame sealing before fitting the frame.

Screw the flush mounting frame in the upper and bottom parts.

Hang the surface mounting frame on the hook in the upper part and then screw it tight in the bottom part.

### Installation of Multiple 2-Modules Next to Each Other

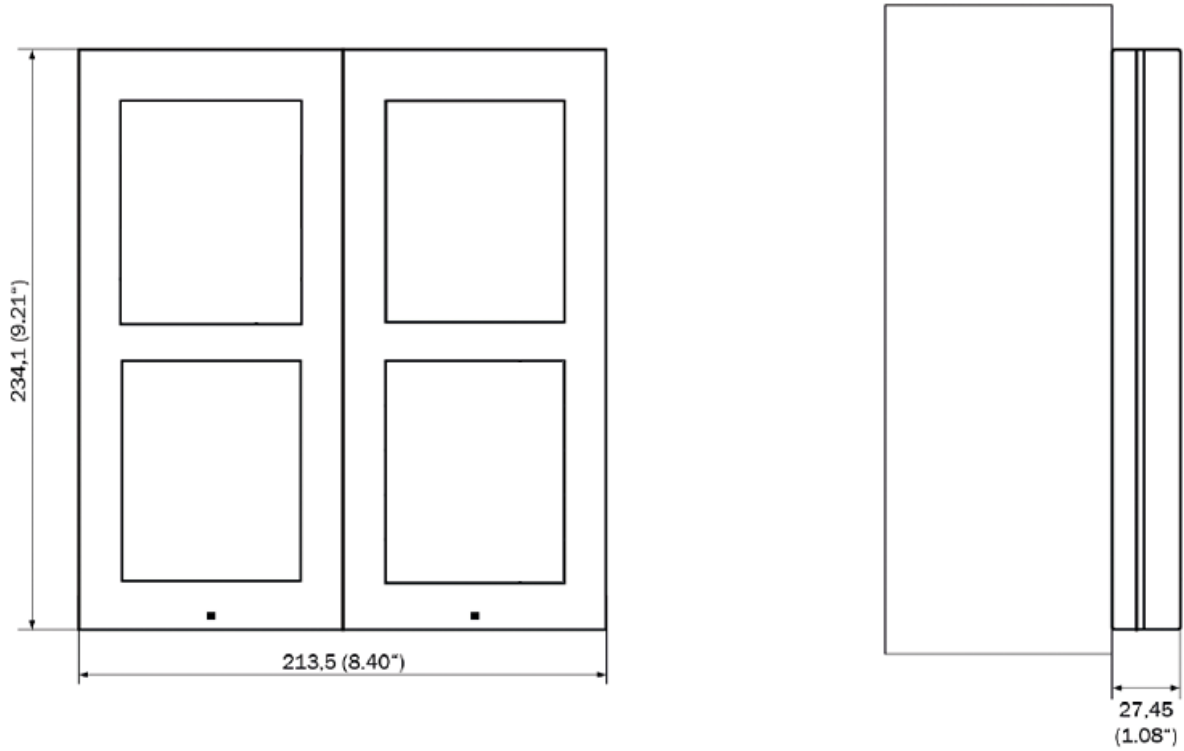

1.

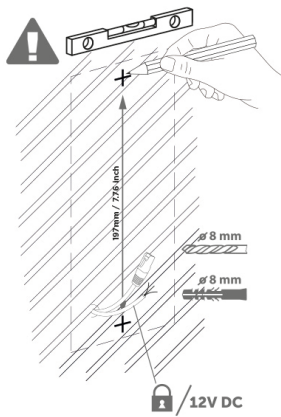

2.

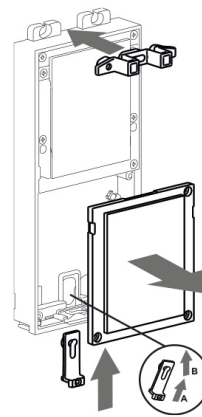

# Installation

3.

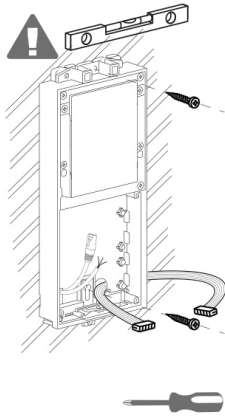

4.

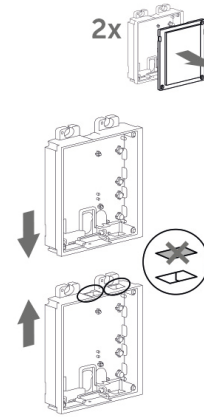

5.

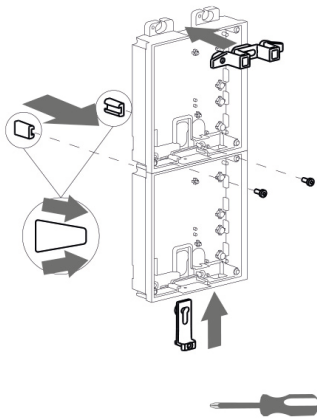

6.

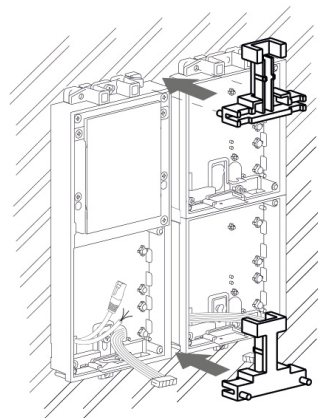

7.

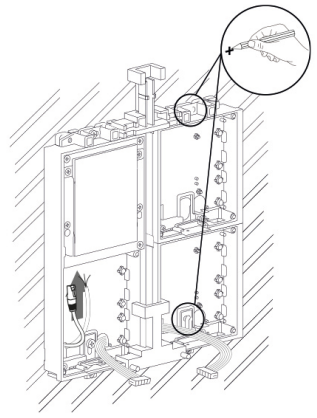

8.

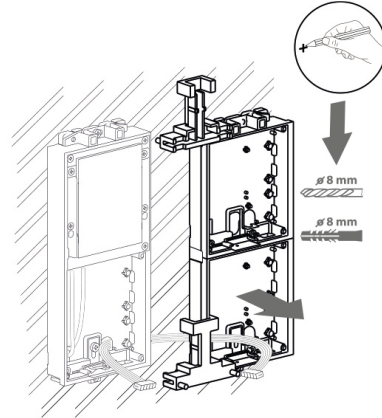

9.

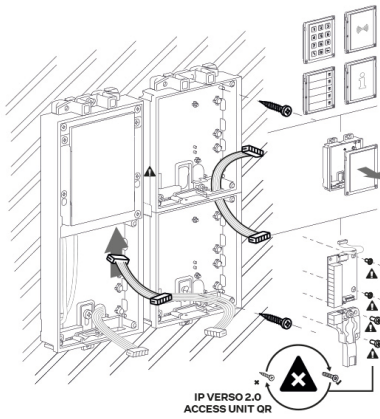

10.

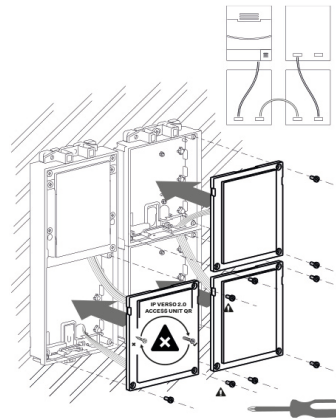

11.

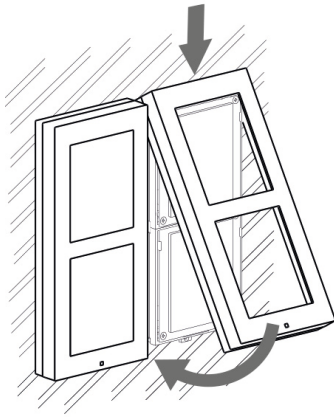

12.

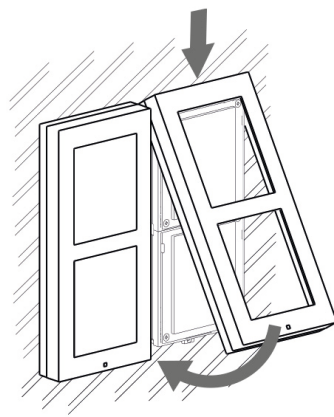

### Frame Attachment

Check the frame sealing before fitting the frame.

Screw the flush mounting frame in the upper and bottom parts.

Hang the surface mounting frame on the hook in the upper part and then screw it tight in the bottom part.

### 3-Module Installation

To install a 3-module, put a 2-module with a 1-module together.

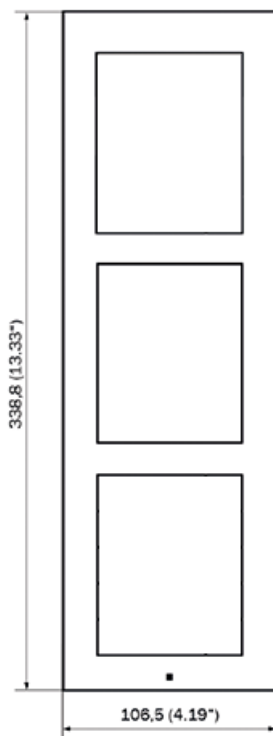



**TIP**

Download the [drilling template](http://2N.com) from 2N.com.

1.

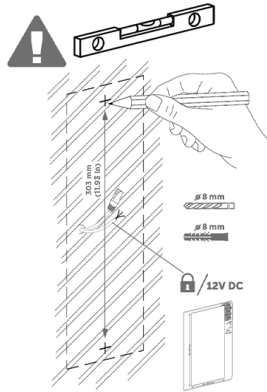

2.

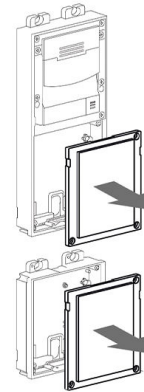

3.

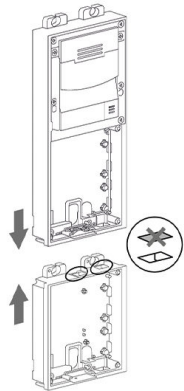

4.

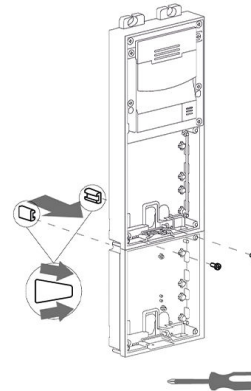

5.

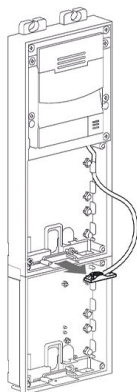

6.

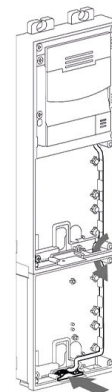

## Installation

7.

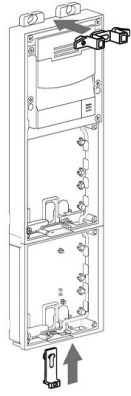

8.

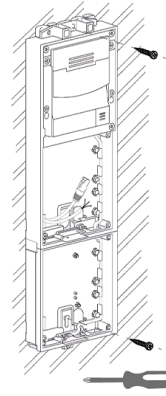

9.

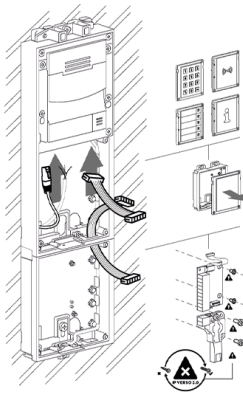

10.

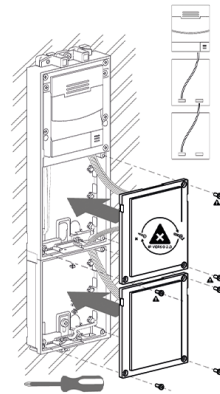

11.

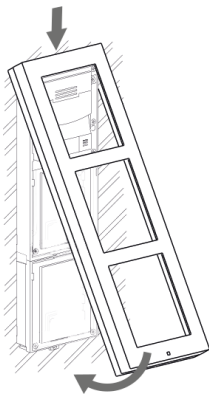

12.



### Frame Attachment

Check the frame sealing before fitting the frame.

Screw the flush mounting frame in the upper and bottom parts.

Hang the surface mounting frame on the hook in the upper part and then screw it tight in the bottom part.

### Installation of Multiple 3-Modules Next to Each Other

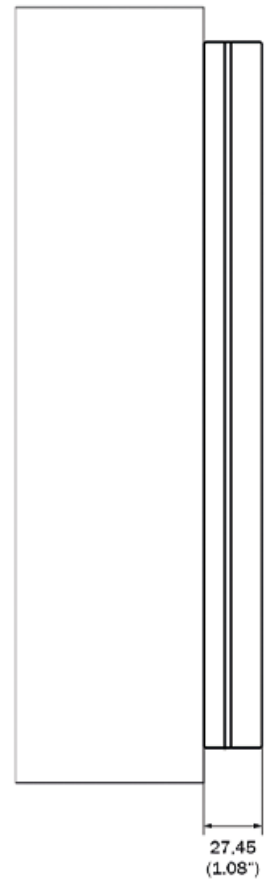
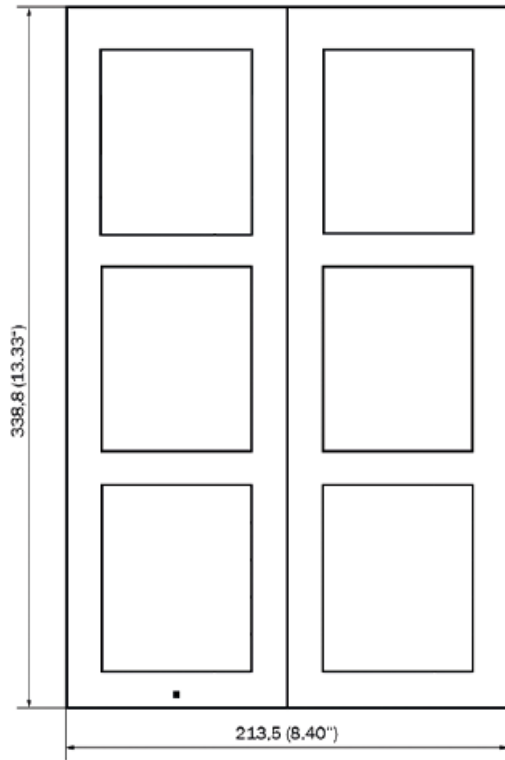

1.

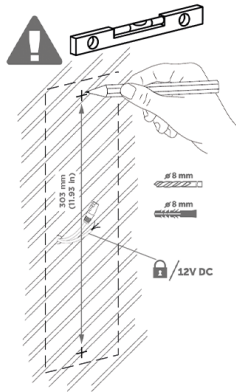

2.

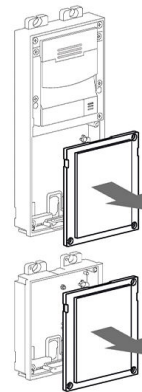

# Installation

3.

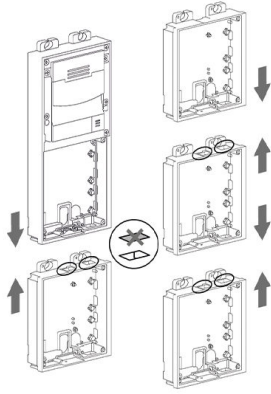

4.

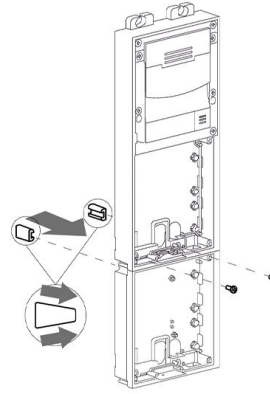

5.

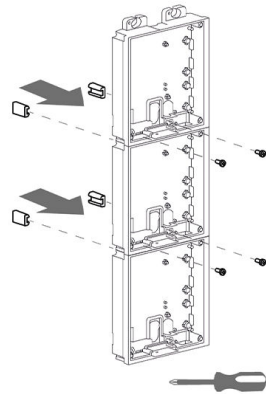

6.

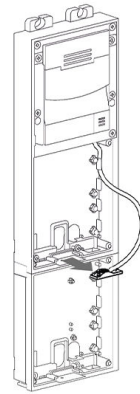

7.

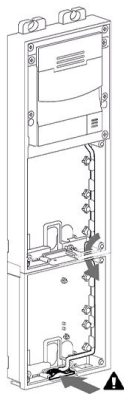

8.

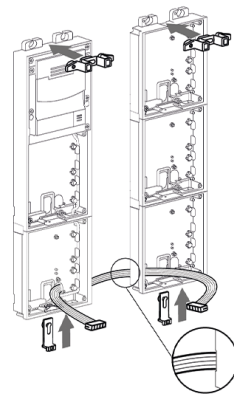

9.

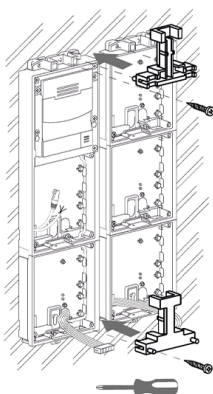

10.

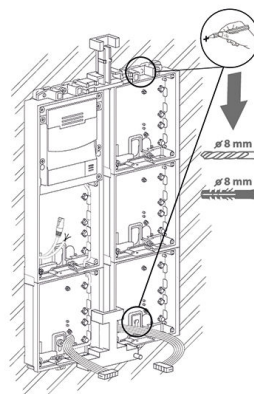

11.

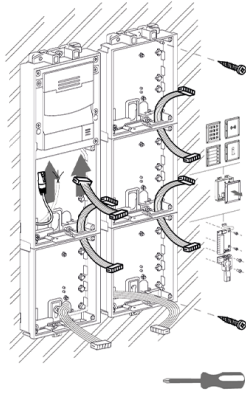

12.

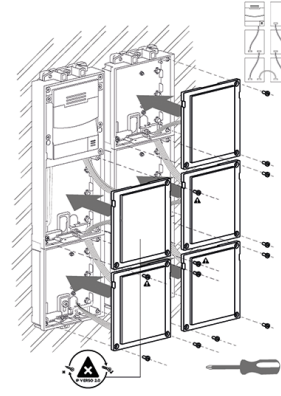

13.

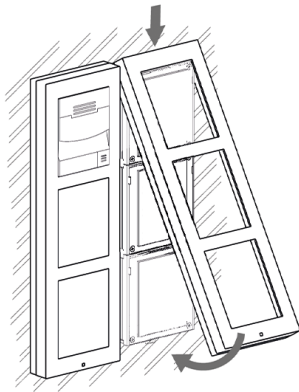

14.



**Frame Attachment**

Check the frame sealing before fitting the frame.

Screw the flush mounting frame in the upper and bottom parts.

Hang the surface mounting frame on the hook in the upper part and then screw it tight in the bottom part.

### 1-Module Installation

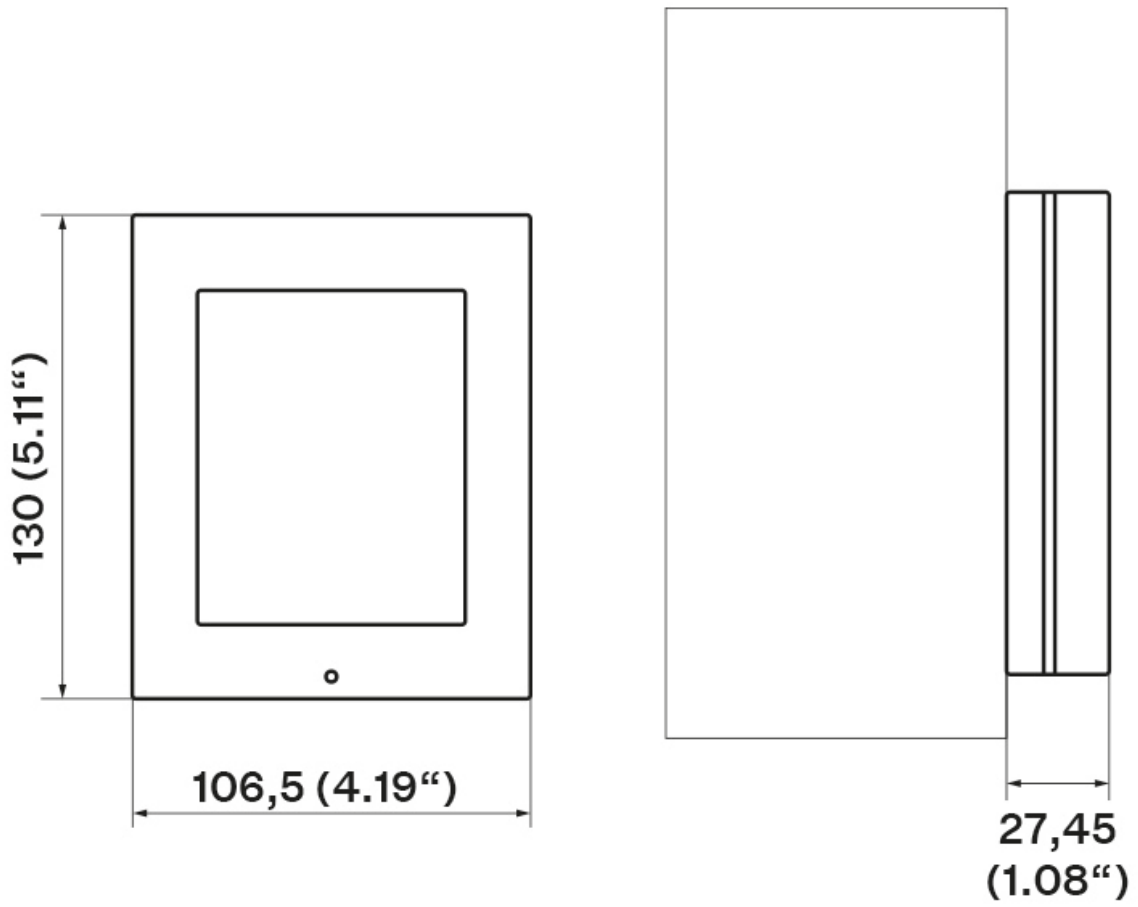

**TIP**  
Download the [drilling template](#) from 2N.com.

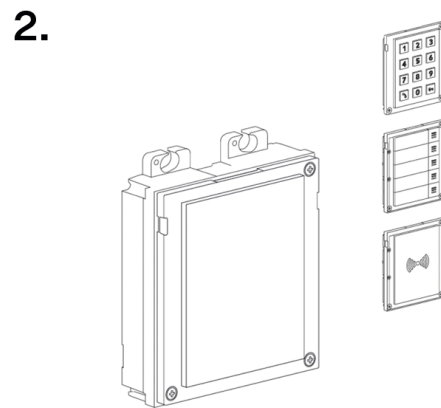
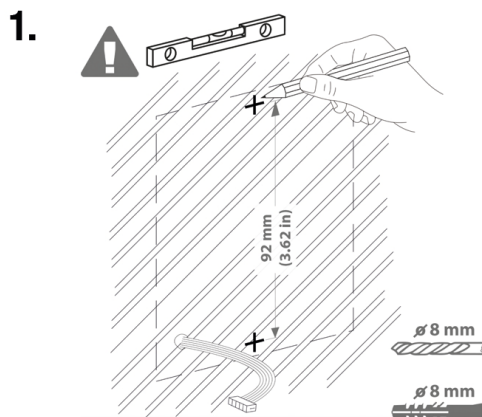

# Installation

3.

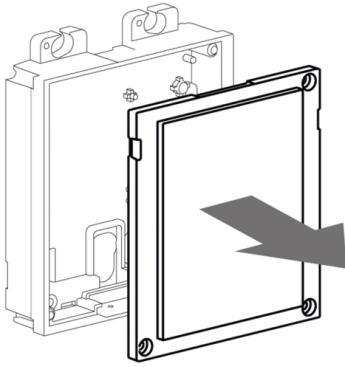

4.

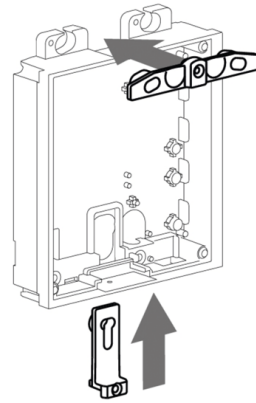

5.

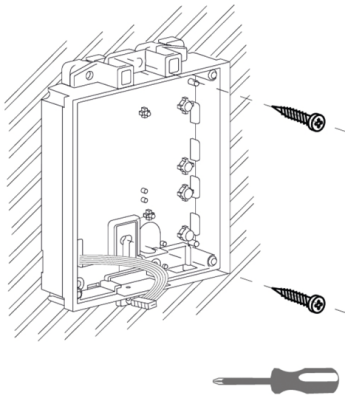

6.

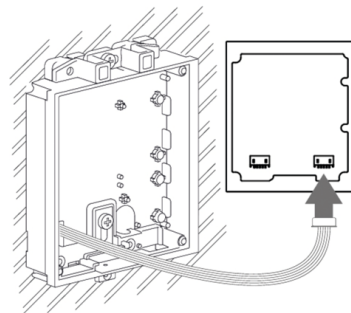

7.

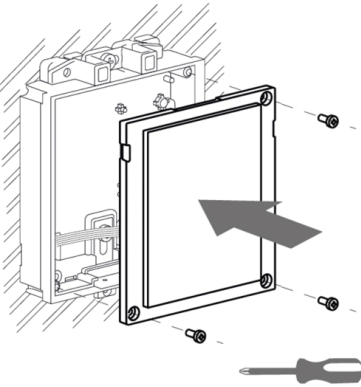

8.

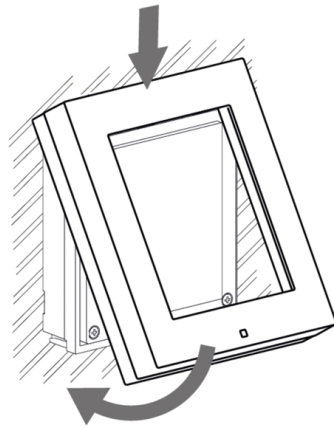

9.

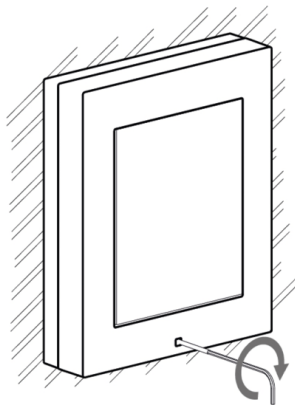

10.

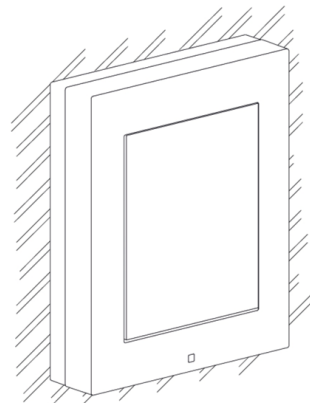

### Frame Attachment

Check the frame sealing before fitting the frame.

Screw the flush mounting frame in the upper and bottom parts.

Hang the surface mounting frame on the hook in the upper part and then screw it tight in the bottom part.

### Backplate Use

For uneven surfaces, use a backplate for the required count of modules (9155061/9155062, 01293-001/01294-001).

### On uneven wall

1.

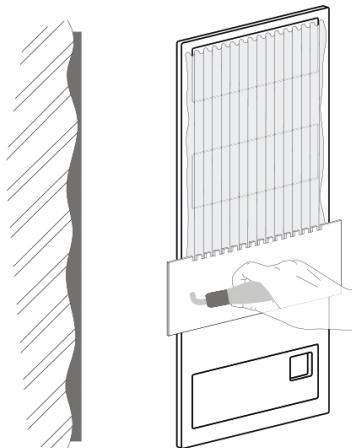

2.

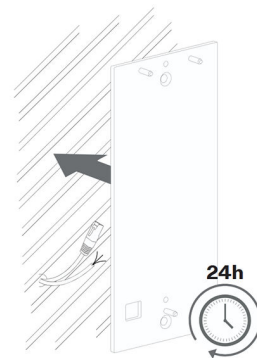

3.

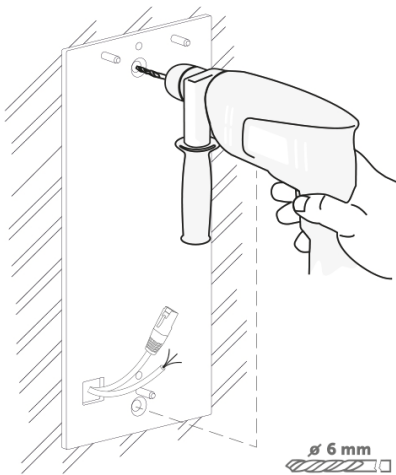

4.

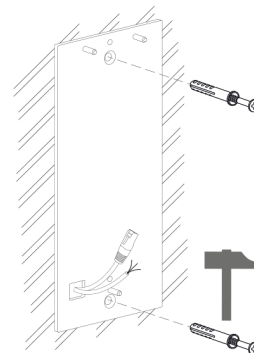

## Installation

5.

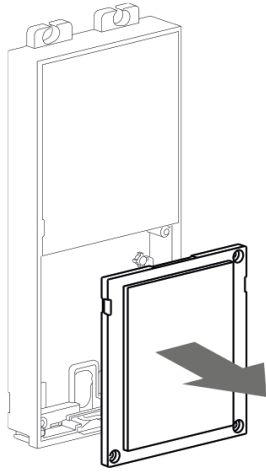

6.

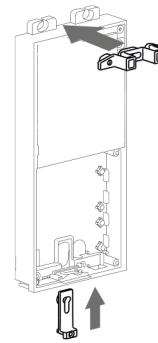

7.

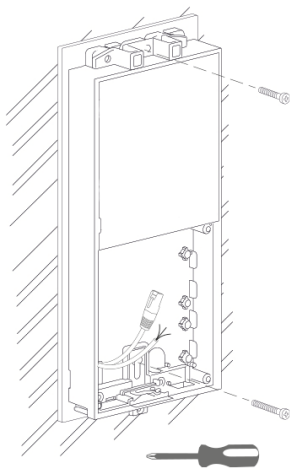

### On glass

The backplate for uneven surfaces can also be used for installation on glass.

1.

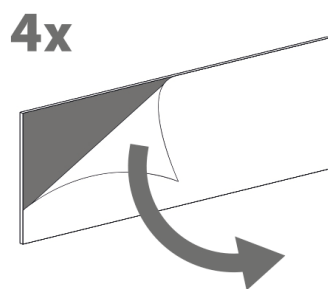

4x

2.

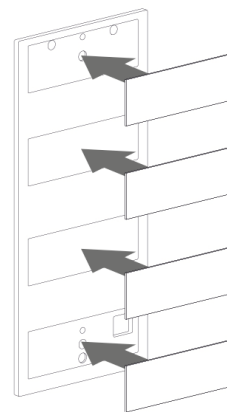

## Installation

3.

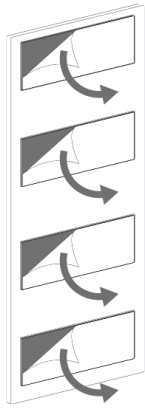

4.

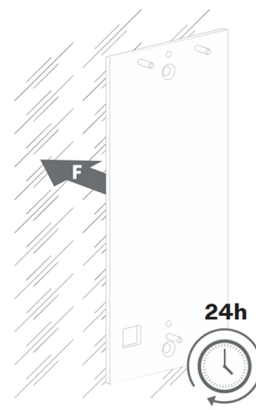

5.

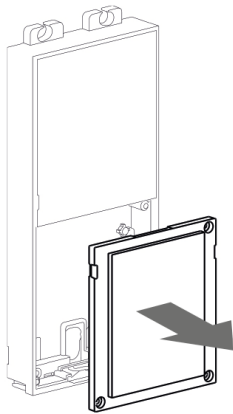

6.

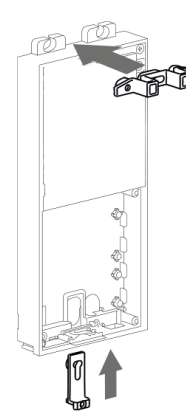

7.

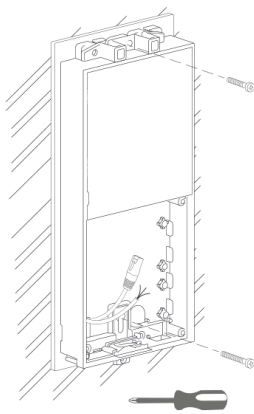

8.

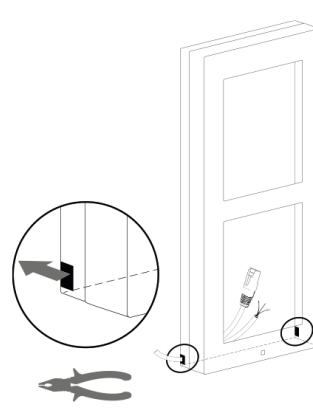

### Surface installation on mounting backplate with tilt

The 2-module slope board is used as a backplate for installations with a tilt of 25°.



#### TIP

Download the [drilling template](https://www.2n.com) from 2N.com

# Installation

1.

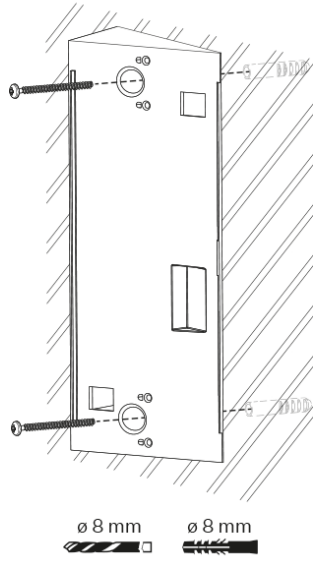

2.

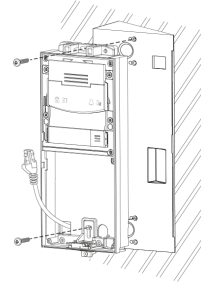

3.

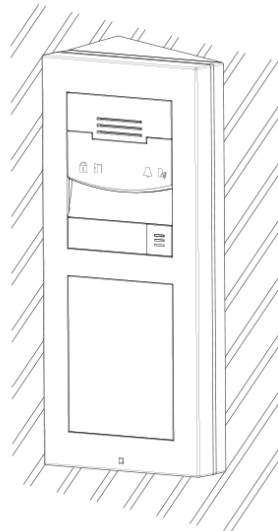

## Stand Installation

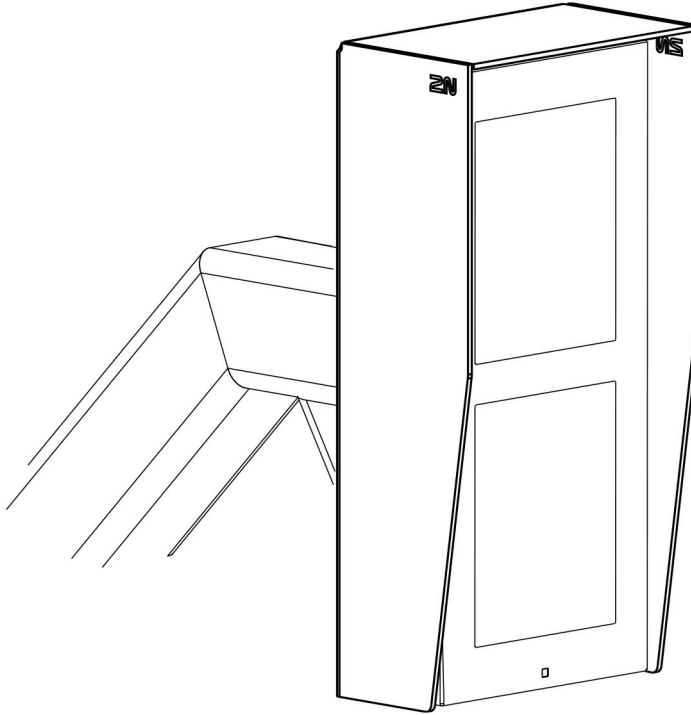

---

What you need for mounting:

- **2N LTE Verso**



### **CAUTION**

Remember to fit the stand to the base thoroughly especially if there is a risk of vandalism (public garages, etc.). Steel fitting elements are recommended.

### Installation procedure

1.

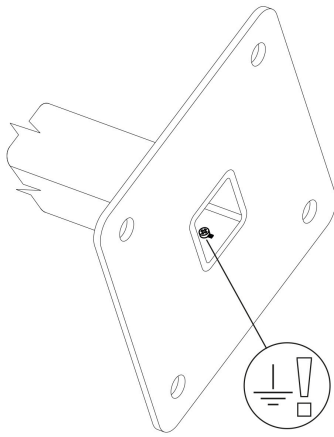

2.

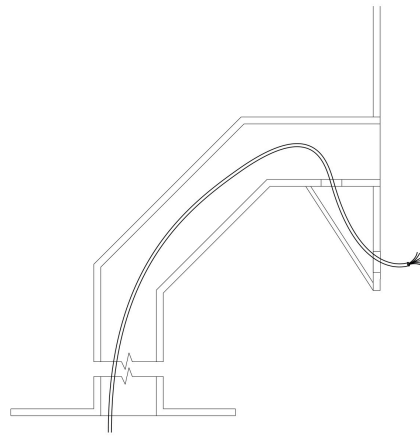

3.

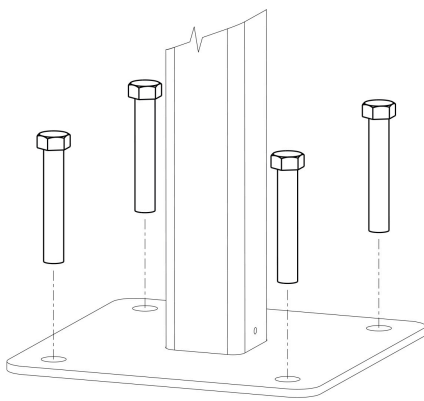

4.

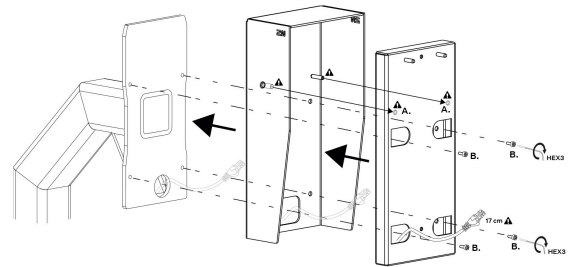

5.

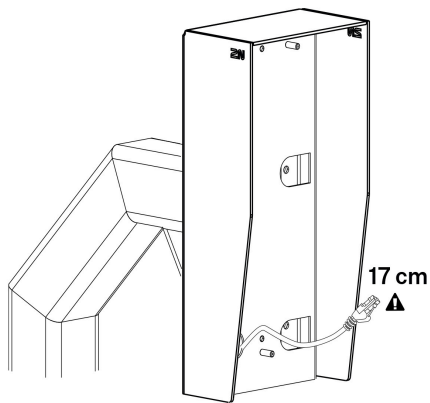

6.

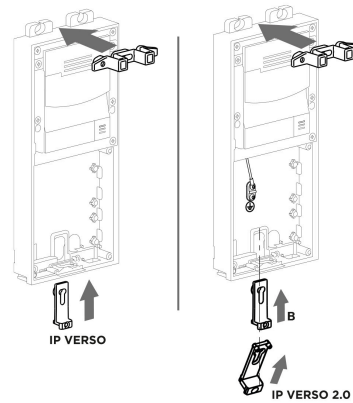

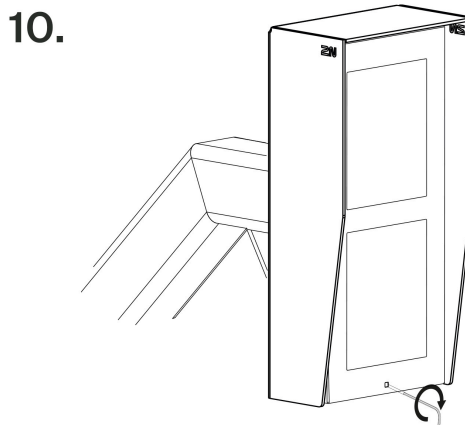
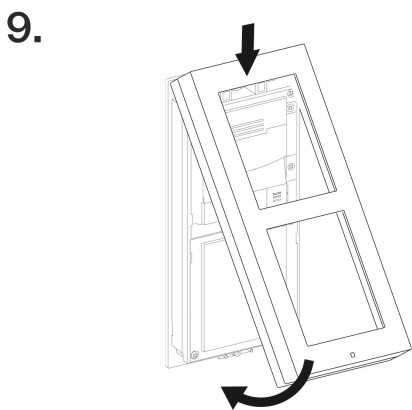
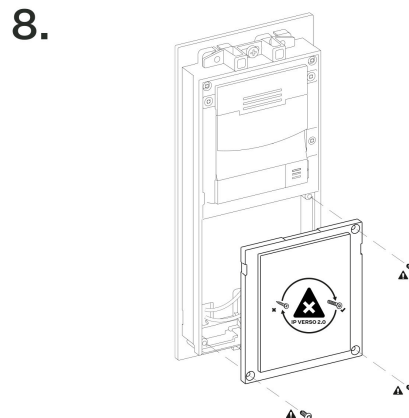
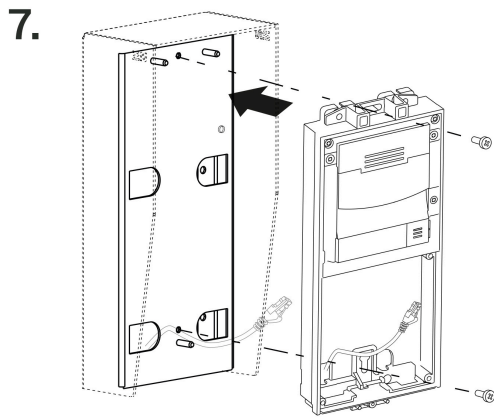

## Electric Installation

### Power Supply

2N LTE Verso can be fed either an external 12 V  $\pm 15\%$  / 2 A DC (3 A for multiple modules) power supply.



#### CAUTION

- The device must be part of the electrical system of the building.
- The external power supply should comply with PS2/LPS.
- Surge protection must be solved directly for the power supply of the device.

### External Power Supply

Use a SELV supply 12 V  $\pm 15\%$  dimensioned to the current consumption according to the required power output for the to make your device work reliably.



#### CAUTION

Make sure that the wires are firmly attached to the terminal to avoid any free contact.

Current consumption [A]	Available power output [W]
2	24
3	36

### Adapter Connection (1341481, 02520-001)

The white wire at the end of the adapter carries the positive charge (+), the black wire carries the negative charge (-).

## Combined Power Supply

### Power Supply Installation

#### Electric Installation Preparation

1. Unscrew the second module bind on the device base.
2. Use a flat screwdriver to take out the second module blind.

#### 2-Module Electric Installation

1. Place the 2-module base on the flush mounting box / predrilled holes with dowels and pull the power cables through the bottom holes.
2. Insert the metal fitting elements up and down and screw the base plate tight. You can level the base slightly if you are mounting just one base.

#### 3-Module Electric Installation

1. Unscrew the blind on the extending 1-module.
2. Use a flat screwdriver to take out the blind.
3. Slide the 1-module to the 2-module base and secure its position with small side wedges and screws.
4. Remove the microphone from the 2-module and loosen its cable.
5. Lead the microphone (as shown in the [mechanical installation \(p. 34\)](#) figures) into the 1-module base.
6. Place the joined bases on the flush mounting box / predrilled holes with dowels and pull the cables through the bottom holes.

#### Electric Installation of Multiple Modules Next to Each Other

1. Unscrew the blinds of the extending bases and take them out using a flat screwdriver.
2. Slide the bases into each other as projected and secure their positions with small side wedges and screws.
3. Place the cover on the flush mounting box / predrilled holes with dowels and pull the cables if any through the bottom holes.
4. Pull the bus using the cable bushing available in the flush mounting box.

## Device Connectors

### Main unit connector wiring

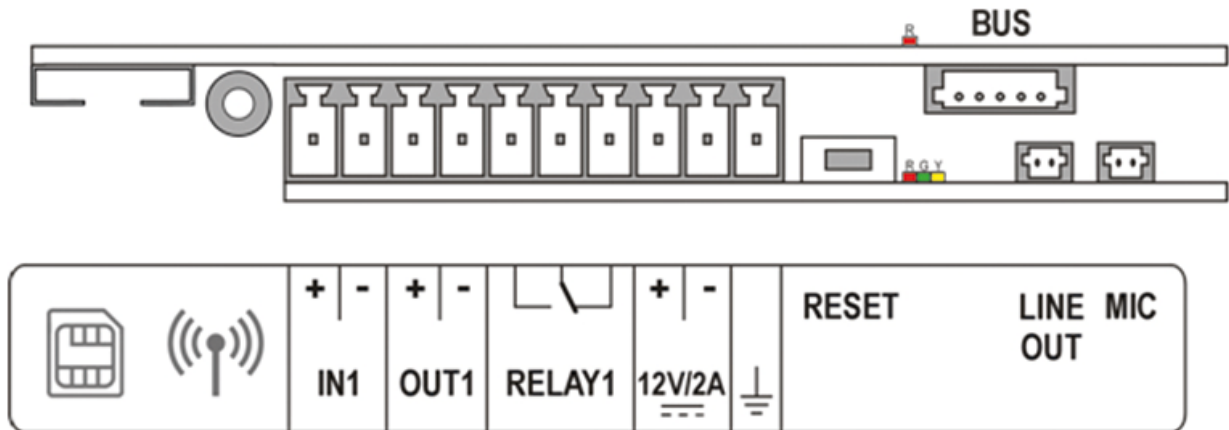

GROUND symbol

Grounding terminal



#### CAUTION

We recommend that a grounding cable of the cross-section of 1.5 mm<sup>2</sup> is used.

MicroSIM symbol

MicroSIM card slot

MMCX antenna connector symbol

LTE mobile network antenna connector

## Installation

IN1	IN1 terminals for input in passive/ active mode (–30 V to +30 V DC) <ul style="list-style-type: none"><li>• OFF = open contact or <math>U_{IN} &gt; 1.5 \text{ V}</math></li><li>• ON = closed contact or <math>U_{IN} &lt; 1.5 \text{ V}</math></li></ul>
OUT1	OUT1 terminals of active input for <a href="#">Security Relay (p. 124)</a> or electric lock connection: 8 up to 12 V DC depending on power supply (adapter: source voltage minus 2 V), up to 400 mA
12 V / 2 A	External power supply terminals 12 V $\pm 15 \%$ / 2 A DC (3 A for multiple modules)
RELAY1	RELAY1 terminals with accessible 30 V / 1 A AC/DC NO/NC contact. Used for connection of non-critical devices only (lights, e.g.).
RGY	LED indicators (red/green/yellow).
R	LED indicator on the upper board (red). A flashing LED signals that the provider's network is being searched for. The LED is off when the provider's network is connected.
RESET	Factory Reset button
BUS	Device bus connector
LINE OUT	External induction loop output. LINE OUT (1 V <sub>RMS</sub> ) connector, type JST SHR-02V-S
MIC	Microphone (MIC) connector

## Available switches

Location	Name	Description
Main unit	RELAY1	<p><b>Passive switch:</b></p> <ul style="list-style-type: none"> <li>switching and expandable contact</li> <li>max. 30 V / 1 A AC/DC</li> <li>only used to connect non-critical devices (e.g. lights)</li> </ul>
	OUT1	<p><b>Active switch output:</b></p> <ul style="list-style-type: none"> <li>8 – 12 V DC depending on the power supply, max. 400 mA                             <ul style="list-style-type: none"> <li>adapter: source voltage -2 V</li> </ul> </li> <li>10 to 12 V DC, max. 600 mA</li> </ul>
I/O module* (9155034, 01257-001)	Extension relay1	<p><b>Passive switch:</b></p> <ul style="list-style-type: none"> <li>make and break contact</li> <li>max. 30 V / 1 A AC/DC</li> <li>only used to connect non-critical devices (e.g. lights)</li> </ul>
	Extension relay2	<p><b>Passive switch:</b></p> <ul style="list-style-type: none"> <li>make and break contact</li> <li>max. 30 V / 1 A AC/DC</li> <li>only used to connect non-critical devices (e.g. lights)</li> </ul>

Multiple modules marked with an asterisk (\*) can be used.



### DANGER

If a coil containing device is connected, e.g. relays/electromagnetic locks, it is necessary to protect the device output against voltage peak while switching off the induction load. For this way of protection we recommend a 1 A / 1000 V diode (e.g., 1N4007, 1N5407, 1N5408) connected antiparallel to the device.

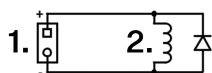

1. Terminals
2. Coil. e.g. relay or electromagnetic lock



**WARNING**

The 12V output is used for lock connection. If the device is installed in a location where there is a danger of unauthorized access (building front, e.g.), we strongly recommend the use of the 2N Security Relay (9159010, 01386-001) to ensure the maximum installation security.

**Relay Terminal Wiring Diagrams**

It is possible to connect a device to the **2N LTE Verso** relay terminals to be controlled by this relay, e.g. an electric/electromechanical door lock.

The elements are designated as follows in the diagrams below:

- 1. Device relay
- 2. Controlled device

**Wiring diagram for the relay terminal output for switching the electric circuit of the controlled device**

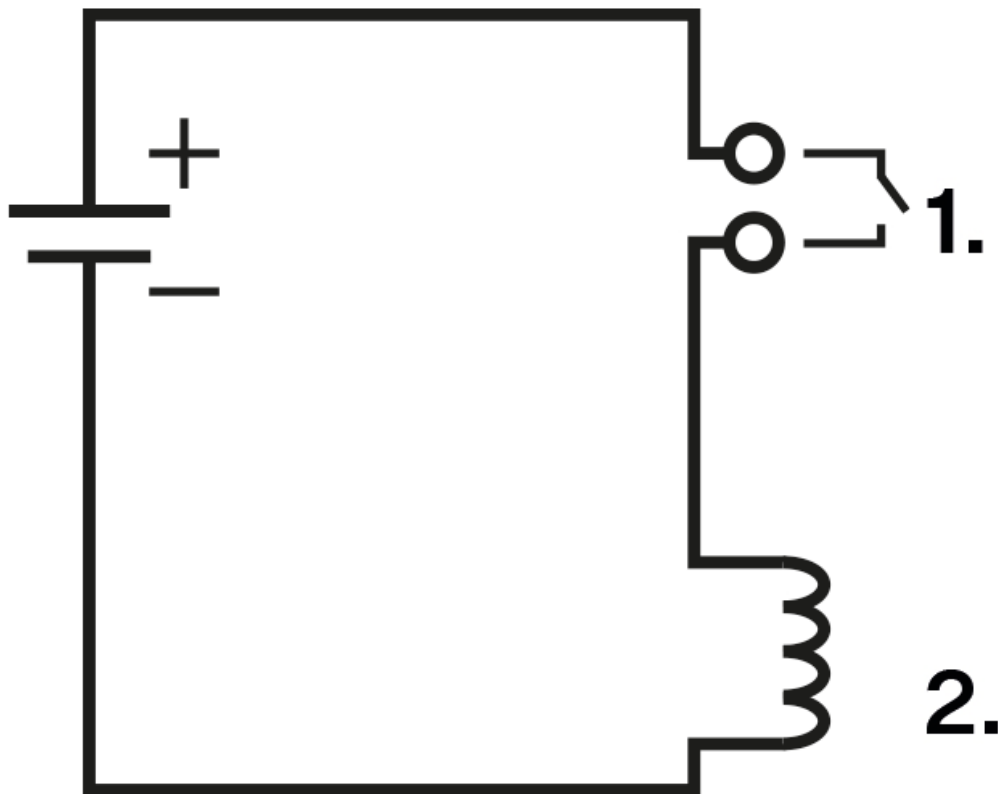

**Connection of IN1 inputs (or IN2)**

It is possible to connect an external button, e.g. a departure button or door open sensor, to the IN1 or IN2 terminals of device **2N LTE Verso**.

The following wiring diagrams apply both to IN1 and IN2.

### Wiring diagram of IN1 terminals in active mode

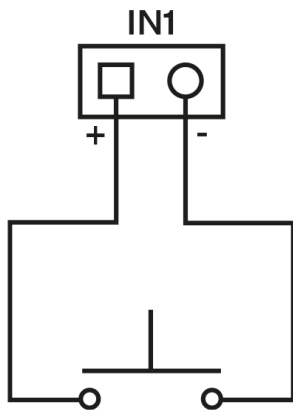

### Wiring diagram of IN1 terminals in passive mode

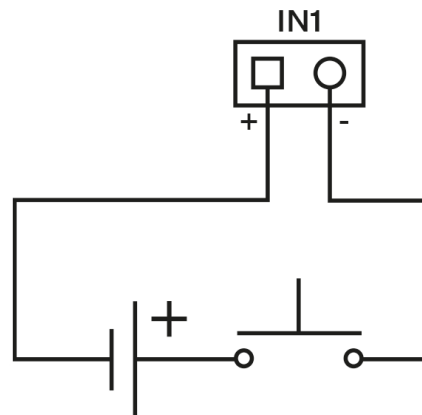

## LTE Mobile Network Connection

Insert your NanoSIM (HW version 4 and higher) or MicroSIM (HW version 3 and lower) card without PIN request with an active data service in order to connect your device to the LTE mobile network. The SIM card is not included in the device package. To get a SIM card, it is recommended that you use services of your preferred LTE data service provider (the device requires the 4G/LTE technology, cannot be operated in the 2G/3G networks). Having inserted your SIM card, connect the supplied antenna stuck to the backside of the blind. If you replace the blind with another module, use an external antenna (optional accessory, Part No. **9155048**).

### SIM Card Insertion - HW version 4 and higher

1. Insert the NanoSIM card in the device and push it gently into the SIM slot to lock its position.
2. Push in the same way to release and partly slide out the inserted SIM card.
3. Now you can remove the card.

### SIM Card Insertion - HW version 3 and lower

1. Slide your MicroSIM card into the SIM slot to insert it in the device.
2. Remove the card in the same way.

## LTE Connection Verification

Having connected the power supply, make sure that **2N LTE Verso** has connected to the LTE mobile data network successfully. The red (R) LED located on the upper board to the left of the BUS connector is used for basic diagnostic. The LED flashes to indicate the connecting process and goes off to signal that the device is connected to the data network. If the LED is on for 5 seconds, there is a SIM card problem (SIM card is not inserted or has no active data service). Another connection attempt is made after 5 seconds of light and the LED starts flashing again, i.e. the LED does not shine permanently in the case of this problem. If the LED keeps flashing, the LTE signal is weak. In that case, check the LTE signal availability in the area and the antenna connector for proper mounting. If the LTE signal is poor, use and install properly an external antenna (optional accessories, Part No. **9155048**). Warning – do not stick an external self-adhesive antenna on metal surfaces!

You can also use the [diagnostic SMS commands](#) for troubleshooting.

## Installation Completion

Check the connection of all the wires and the antenna in the board connector.



**WARNING**

- Make sure that all the terminals of the unused connectors are properly tightened to avoid vibrations caused by sound.
- An incorrectly made installation may compromise the device waterproofness. Water infiltration may damage the electronic part.
- Make sure that all the holes are filled with some waterproof material – the top part, around the cables and the screws.
- Use silicone or some other sealant to seal the box against an uneven wall. Thus, you prevent water leakage and wall damping.

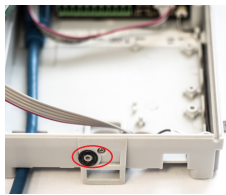

Make sure before mounting that the black sealing ring is placed properly. We recommend that the microphone is fitted with the screw included in the delivery.

**Frame Attachment**

Check the frame sealing before fitting the frame.

Screw the flush mounting frame in the upper and bottom parts.

Hang the surface mounting frame on the hook in the upper part and then screw it tight in the bottom part.

**Name Tags**

**Name Tag Printing**

1. A sheet of translucent foil is enclosed to every device. Print it using a laser printer.
2. Cut the printed foil into individual labels.



**TIP**

Refer to the [Support & Download Center](#) section at 2N.com for the name tag printing template.

- 1 button: 52.0 (W) x 15.2 (H) mm (dimensional tolerance: +0; -0.5 mm)
- 5-button: 57.5 (W) x 89.0 (H) mm (dimensional tolerance: +0; -0.5 mm)
- Infopanel module nametag sizes: 69.2 (W) x 86.7 (H) mm (dimensional tolerance: +0; - 0.5 mm).



**CAUTION**

- The area where the name tags are located is a so-called wet zone. It is because water may get onto the film during heavy rainfalls. Water in this area does not affect the function of the device and evaporates spontaneously.
- Always use waterproof foil (enclosed or other) for the nametags. Never use paper to avoid damage due to water leakage! Never use ink jet printing for the same reason!

## Name Tag Insertion/Replacement

1. Remove the module frame.
2. Lift up the button door. Lift up the button door for all the buttons on the 5-button module.
3. Remove the used nametag and insert a new one.
4. Close the button door.
5. Replace the module frame.
  - a. Fit the flush mounting frame top and bottom with screws.
  - b. Hitch the surface mounting frame on the hook on top and screw it in the bottom.

## Name Tag Insertion/Replacement

The advantage of **2N LTE Verso** is its intuitive, simple access to name tags. There is no need to remove the front panel for replacement and so there is no risk of losing parts.

1. Loosen the name plate screw using the wrench enclosed, for example. You can open the name plate window like a door without losing the tightened screw.
2. Remove the used or blank name tag and insert a new tag.
3. Close the name plate window and tighten the screw appropriately.
4. Check the click effect of the button: if the button fails to click properly when pressed (when moved by approx. 0.5 mm), the tag is too thick or thin. Make sure that the button clicks when you press it on both ends.

## Nametag Insertion/Replacement

1. Remove the module frame.
2. Lift up the button door. Lift up the button door for all the buttons on the 5-button module.
3. Remove the used nametag and insert a new one.
4. Close the button door.
5. Replace the module frame.
  - a. Fit the flush mounting frame top and bottom with screws.
  - b. Hitch the surface mounting frame on the hook on top and screw it in the bottom.



### WARNING

- Make sure that all the terminals of the unused connectors are properly tightened to avoid vibrations caused by sound.
- An incorrectly made installation may compromise the device waterproofness. Water infiltration may damage the electronic part.
- Make sure that all the holes are filled with some waterproof material – the top part, around the cables and the screws.
- Use silicone or some other sealant to seal the box against an uneven wall. Thus, you prevent water leakage and wall damping.

## Tactile stickers

Special tactile stickers with raised surfaces are included in the package. These stickers help people with visual impairments to recognize the basic controls of the device.

We recommend placing the sticker on the primary quick dial button. Place the sticker on the button edge and adjust the text on the label as needed to make it legible and not obscured by the sticker.



**NOTE**

Clean the device surface from dust and dirt before applying the sticker.

## Most Frequent Installation Errors

Always mount the metal bolts and level the bases on an even surface **before** tightening the screws.



**WARNING**

Make sure that the bases are levelled properly to avoid water leakage and electronic damage.



See the side view in the drawing above for the right/wrong connection of the bases. Pay particular attention to the base connection detail. You may have a situation especially when the instructions are neglected and the screws are tightened first.

# Main and Extending Modules



## CAUTION

In case the firmware versions of the module to be connected and the main unit are incompatible, the module will not be detected. Therefore, update the device firmware after connecting the modules. Update firmware via the web configuration interface in System > Maintenance.



## TIP

To accelerate access card reading, we recommend that the used card types are only selected in the module settings.

**2N LTE Verso** can be interconnected with the following modules:

- [125 kHz RFID card reader \(p. 111\)](#)
- [13.56 MHz NFC RFID card reader \(p. 112\)](#)
- [Secured 13.56 MHz, NFC RFID card reader \(p. 112\)](#)
- [125 kHz, 13.56 MHz, NFC Bluetooth & RFID card reader \(p. 112\)](#)
- [125 kHz, secured 13.56 MHz, NFC Bluetooth & RFID card reader \(p. 113\)](#)
- [125kHz, 13.56MHz, NFC touch keypad & RFID card reader \(p. 114\)](#)
- [125kHz, secured 13.56MHz, NFC touch keypad & RFID card reader \(p. 114\)](#)
- [125 kHz, 13.56 MHz, NFC touch keypad & Bluetooth & RFID card reader \(p. 115\)](#)
- [125 kHz, secured 13.56 MHz, NFC touch keypad & Bluetooth & RFID card reader \(p. 115\)](#)
- [Touch keypad \(p. 116\)](#)
- [Biometric fingerprint reader \(p. 116\)](#)
- [Touch display \(p. 117\)](#)
- [5-button \(p. 118\)](#)
- [Keypad \(p. 118\)](#)
- [I/O module \(p. 118\)](#)
- [Wiegand module \(p. 120\)](#)
- [Security Relay \(p. 124\)](#)
- [Tamper Switch module \(p. 126\)](#)
- [OSDP module \(p. 128\)](#)
- [Induction Loop module \(p. 132\)](#)
- [Infopanel \(p. 132\)](#)
- [Blind panel module \(p. 133\)](#)

## Module Interconnection

All the modules that can be connected to the device are interconnected via a bus. The bus starts on the main unit and goes over all the modules. The order of the modules on the bus is irrelevant. And it is also irrelevant which bus connector is used as the input and which is used as the output on the module.

The modules include a 220 mm long bus interconnecting cable.

## Main and Extending Modules

The Wiegand, OSDP and I/O modules include an 80 mm long bus cable. These modules can be hidden inside one of the modules described below (Infopanel, Keypad, RFID card reader, Bluetooth) or can be freely placed behind the device (in a mounting box, e.g.). The Tamper Switch, which is not on the bus, is interconnected with one of these modules.

It is possible to order separate bus cables of the length of 1 m, 3 m or 5 m (9155050/9155054/9155055, 01267-001/01268-001/01269-001 respectively), which are intended for remote module installations. Typically, they help install an RFID card reader on the opposite side of the wall on which the device communicator is installed. This cable may only be used once on the bus. The total length of all the bus cables used in these extended installations may not exceed 7 m.

The modules can be combined in each base as follows:

Module	External mounting into the device base (the module is visible):	Internal mounting into the device base (the module is not visible):	Internal mounting on the base bottom edge
Infopanel	✓	✗	✗
Keypad	✓	✗	✗
Touch keypad	✓	✗	✗
125 kHz RFID card reader	✓	✗	✗
13.56 MHz RFID card reader	✓	✗	✗
13.56 MHz, NFC RFID card reader	✓	✗	✗
Secured 13.56 MHz, NFC RFID card reader	✓	✗	✗
125 kHz, 13.56 MHz, NFC Bluetooth & RFID card reader	✓	✗	✗
125kHz, secured 13.56MHz, NFC Bluetooth & RFID card reader	✓	✗	✗

## Main and Extending Modules

Module	External mounting into the device base (the module is visible):	Internal mounting into the device base (the module is not visible):	Internal mounting on the base bottom edge
125kHz, 13.56MHz, NFC touch keypad & RFID card reader	✓	✗	✗
125kHz, secured 13.56MHz, NFC touch keypad & RFID card reader	✓	✗	✗
Bluetooth reader	✓	✗	✗
Touch display	✓	✗	✗
Induction loop	✓	✗	✗
Fingerprint reader	✓	✗	✗
I/O	✗	✓	✗
5-Button	✓	✗	✗
Wiegand	✗	✓	✗
Tamper Switch	✗	✗	✓
Blind panel	✓	✗	✗

## Module Power Supply

All the modules connected to the device, except for the Tamper Switch, are powered from the bus. The available bus power output depends on the power supply type.

The main unit with motherboard allows an external power supply to be used for increasing the available power output for the modules connected.

Power Supply	Specification	Available power output
External supply	12 V $\pm$ 15 % / 2 A DC (3 A for multiple modules)	24 W (36 W)

### Sample Calculations

The count of modules on the bus is limited by the available power supply output. The maximum count of the modules on the bus is 30.

Main unit with motherboard	Maximum consumption [W]
At relax	2.376
Infrared illumination	3.06
LED – call	0.072
LED – ringing	0.072
LED – lock	0.072
LED – secured	0.096
Button backlight	0.072
Nametag backlight	0.072
Unit backlight	0.072
Relay 1	0.132
OUT1	4.8
Audio	2.94

## Main and Extending Modules

Main unit with motherboard	Maximum consumption [W]
----------------------------	-------------------------

**Total**

**15.05**

Module	Maximum idle consumption [W]	Full load [W]
--------	------------------------------	---------------

Main unit with camera

2.36

Main unit without camera

Infopanel

0.17

0.35

Keypad

0.12

1.54

Touch keypad

0.12

1.54

Fingerprint reader

0.73

1.54

125 kHz RFID card reader

0.52

1.31

13.56 MHz RFID card reader

0.44

0.82

RFID card reader 13.56 MHz, NFC

0.44

0.82

Secured 13.56 MHz NFC RFID card reader

0.44

0.82

Touch display

1.16

2.02

Induction loop

0.18

2.99

Fingerprint scanner

0.73

1.54

## Main and Extending Modules

Module	Maximum idle consumption [W]	Full load [W]
I/O module	0.31 (+ 0.13 for relay activation)	0.65
5-button	0.19	0.19
OSDP	0.52	0.52
Wiegand module	0.46	0.46
Tamper Switch	0.31	0.65
Blind panel	×	×

## Specimen configuration consumption computation

Module	Maximum consumption [W]	Maximum consumption [W]
Main unit with camera	2.36	11.57 12,5
13.56 MHz RFID card reader	0.44	0.82
I/O	0.31	0.65
5-button	0.19	1.16
Touch display	1.16	2.02
Tamper Switch	0.31	0.65
Wiegand	0.46	0.46
Bluetooth reader	0.2	0.67

Module	Maximum consumption [W]	Maximum consumption [W]
<b>Total</b>	<b>8.574</b>	<b>21.53</b>

Some modules need a specific power output for their specific activities: the I/O module, e.g., requires 0.13 W for relay activation (not included in the minimum consumption).

## Module Specifications



### CAUTION

**2N LTE Verso** supports connection of just one Bluetooth module. If connected, multiple Bluetooth modules may result in a undesired behavior.



### TIP

To accelerate access card reading, we recommend that the used card types are only selected in the module settings.

## 125 kHz RFID Card Reader Module

The 125 kHz RFID card reader module (91550941, 02140-001) is used for reading RFID card IDs in the 125 kHz bandwidth.

To accelerate access card reading, we recommend that the used card types are only selected in the module settings.



### CAUTION

We recommend that the M-Bus and LAN cable are not crossed but carried separately through separate bushings to increase the reading distance of this reader & touch display installation.

## Features

- The module contains two bus connectors for the **2N LTE Verso** bus.
- These two connectors are fully interchangeable and can be used either as inputs from the main unit or outputs to other modules.
- If this module is the last one on the bus, one of the connectors remains unconnected.
- The module package includes a 220 mm long interconnecting cable.

Supported RFID cards 125 kHz:

- EM4x02
- NXP HiTag2

### **13.56 MHz, NFC RFID Card Reader Module**

The 13.56 MHz RFID card reader (91550942, 02139-001) is used for reading RFID card IDs in the 13.56 kHz bandwidth.

To accelerate access card reading, we recommend that the used card types are only selected in the module settings.

#### **Features**

- The module contains two bus connectors for the **2N LTE Verso** bus.
- These two connectors are fully interchangeable and can be used either as inputs from the main unit or outputs to other modules.
- If this module is the last one on the bus, one of the connectors remains unconnected.
- The module package includes a 220 mm long interconnecting cable.

Supported RFID cards 13.56 MHz:

- **ISO14443A** (MIFARE Classic, MIFARE Plus, MIFARE Mini, MIFARE Ultralight, MIFARE DESFire CSN only)
- **PicoPass** (HID iClass CSN, Picopass)
- **FeliCa** (Standard, Lite)
- **ST SR** (SR, SRI, SRIX)
- **My2N**
- **2N PICard**

### **Secured 13.56 MHz NFC RFID Card Reader Module**

The 13.56 MHz RFID card reader (91550942-S/9155086, 02141-001/01712-001) is used for reading secured RFID card IDs in the 13.56 MHz bandwidth.

#### **Features**

- The module contains two bus connectors for the **2N LTE Verso** bus.
- These two connectors are fully interchangeable and can be used either as inputs from the main unit or outputs to other modules.
- If this module is the last one on the bus, one of the connectors remains unconnected.
- The module package includes a 220 mm long interconnecting cable.

Supported RFID cards 13.56 MHz:

- **ISO14443A** (MIFARE Classic, MIFARE Plus, MIFARE Mini, MIFARE Ultralight, MIFARE DESFire CSN only)
- **PicoPass** (HID iClass CSN, Picopass)
- **FeliCa** (Standard, Lite)
- **ST SR** (SR, SRI, SRIX)
- **HID PAC** (HID SEOS, HID iClass SE, iClass SR, HID MIFARE DESFire with SIO, HID MIFARE Classic with SIO)
- **My2N**
- **2N PICard**

### **Bluetooth & 125 kHz, 13.56 MHz, NFC RFID Card Reader Module**

The Bluetooth & 125 kHz and 13.56 MHz card reader module (91550945, 02778-001) is used for access control using a smartphone/tablet with **My2N** or an access card, for making user calls and/or controlling other functions.

To accelerate access card reading, we recommend that the used card types are only selected in the module settings.

## Features

- NFC – for **2N My2N** for Android only, a licensed function.
- The module contains two bus connectors for the **2N LTE Verso** bus.
- These two connectors are fully interchangeable and can be used either as inputs from the main unit or outputs to other modules.
- If this module is the last one on the bus, one of the connectors remains unconnected.
- The module package includes a 220 mm long interconnecting cable.

Supported RFID cards 125 kHz:

- EM4x02
- NXP HiTag2

Supported RFID cards 13.56 MHz:

- **ISO14443A** (MIFARE Classic, MIFARE Plus, MIFARE Mini, MIFARE Ultralight, MIFARE DESFire CSN only)
- **PicoPass** (HID iClass CSN, Picopass)
- **FeliCa** (Standard, Lite)
- **ST SR** (SR, SRI, SRIX)
- **My2N**
- **2N PICard**

## Bluetooth & 125 kHz, secured 13.56 MHz, NFC RFID Card Reader Module

The Bluetooth & 125 kHz and secured 13.56 MHz card reader module (91550945-S, 02444-001) is used for access control using a smartphone/tablet with **2N My2N** or an access card, for making user calls and/or controlling other functions.

To accelerate access card reading, we recommend that the used card types are only selected in the module settings.

## Features

- NFC – for **2N My2N** for Android only, a licensed function.
- The module contains two bus connectors for the **2N LTE Verso** bus.
- These two connectors are fully interchangeable and can be used either as inputs from the main unit or outputs to other modules.
- If this module is the last one on the bus, one of the connectors remains unconnected.
- The module package includes a 220 mm long interconnecting cable.

Supported RFID cards 125 kHz:

- EM4x02
- NXP HiTag2

Supported RFID cards 13.56 MHz:

- **ISO14443A** (MIFARE Classic, MIFARE Plus, MIFARE Mini, MIFARE Ultralight, MIFARE DESFire CSN only)
- **PicoPass** (HID iClass CSN, Picopass)
- **FeliCa** (Standard, Lite)
- **ST SR** (SR, SRI, SRIX)
- **HID PAC** (HID SEOS, HID iClass SE, iClass SR, HID MIFARE DESFire with SIO, HID MIFARE Classic with SIO)

- **My2N**
- **2N PICard**

### **Touch Keypad & 125 kHz, 13.56 MHz, NFC RFID Card Reader Module**

The touch keypad & 125 kHz and 13.56 MHz card reader module (91550946, 02779-001) is used for code/card access control, making user calls and/or controlling other functions. The touch keypad surface is very sensitive yet weatherproof at the same time.

To accelerate access card reading, we recommend that the used card types are only selected in the module settings.

#### **Features**

- NFC – for **2N My2N** for Android only, a licensed function.
- The module contains two bus connectors for the **2N LTE Verso** bus.
- These two connectors are fully interchangeable and can be used either as inputs from the main unit or outputs to other modules.
- If this module is the last one on the bus, one of the connectors remains unconnected.
- The module package includes a 220 mm long interconnecting cable.

Supported RFID cards 125 kHz:

- EM4x02
- NXP HiTag2

Supported RFID cards 13.56 MHz:

- **ISO14443A** (MIFARE Classic, MIFARE Plus, MIFARE Mini, MIFARE Ultralight, MIFARE DESFire CSN only)
- **PicoPass** (HID iClass CSN, Picopass)
- **FeliCa** (Standard, Lite)
- **ST SR** (SR, SRI, SRIX)
- **My2N**
- **2N PICard**

### **Touch Keypad & 125 kHz, secured 13.56 MHz, NFC RFID Card Reader Module**

The touch keypad with a combined 125 kHz and secured 13.56 MHz card reader (91550946-S, 02443-001) is used for code/card access control, making user calls and/or controlling other functions. The touch keypad surface is very sensitive yet weatherproof at the same time.

To accelerate access card reading, we recommend that the used card types are only selected in the module settings.

#### **Features**

- NFC – for **2N My2N** for Android only, a licensed function.
- The module contains two bus connectors for the **2N LTE Verso** bus.
- These two connectors are fully interchangeable and can be used either as inputs from the main unit or outputs to other modules.
- If this module is the last one on the bus, one of the connectors remains unconnected.
- The module package includes a 220 mm long interconnecting cable.

Supported RFID cards 125 kHz:

- EM4x02
- NXP HiTag2

Supported RFID cards 13.56 MHz:

- **ISO14443A** (MIFARE Classic, MIFARE Plus, MIFARE Mini, MIFARE Ultralight, MIFARE DESFire CSN only)
- **PicoPass** (HID iClass CSN, Picopass)
- **FeliCa** (Standard, Lite)
- **ST SR** (SR, SRI, SRIX)
- **HID PAC** (HID SEOS, HID iClass SE, iClass SR, HID MIFARE DESFire with SIO, HID MIFARE Classic with SIO)
- **My2N**
- **2N PICard**

### **Touch Keypad & Bluetooth & 125 kHz, 13.56 MHz, NFC RFID Card Reader Module**

The touch keypad with Bluetooth and a combined 125 kHz and 13.56 MHz card reader (91550947, 02781-001) is used for access control using a smartphone/tablet with **2N My2N** or code/access card, for making user calls and/or controlling other functions. The touch keypad surface is very sensitive yet weather-proof at the same time.

To accelerate access card reading, we recommend that the used card types are only selected in the module settings.

#### **Features**

- NFC – for **2N My2N** for Android only, a licensed function.
- The module contains two bus connectors for the **2N LTE Verso** bus.
- These two connectors are fully interchangeable and can be used either as inputs from the main unit or outputs to other modules.
- If this module is the last one on the bus, one of the connectors remains unconnected.
- The module package includes a 220 mm long interconnecting cable.

Supported RFID cards 125 kHz:

- EM4x02
- NXP HiTag2

Supported RFID cards 13.56 MHz:

- **ISO14443A** (MIFARE Classic, MIFARE Plus, MIFARE Mini, MIFARE Ultralight, MIFARE DESFire CSN only)
- **PicoPass** (HID iClass CSN, Picopass)
- **FeliCa** (Standard, Lite)
- **ST SR** (SR, SRI, SRIX)
- **My2N**
- **2N PICard**

### **Touch Keypad & Bluetooth & 125 kHz, secured 13.56 MHz, NFC RFID Card Reader Module**

The touch 02781-001keypad & Bluetooth & 125 kHz and secured 13.56 MHz card reader module (91550947-S, 02782-001) is used for access control using a smartphone/tablet with **2N My2N** or code/access card, for making user calls and/or controlling other functions. The touch keypad surface is very sensitive yet weatherproof at the same time.

To accelerate access card reading, we recommend that the used card types are only selected in the module settings.

#### **Features**

- NFC – for **2N My2N** for Android only, a licensed function.

- The module contains two bus connectors for the **2N LTE Verso** bus.
- These two connectors are fully interchangeable and can be used either as inputs from the main unit or outputs to other modules.
- If this module is the last one on the bus, one of the connectors remains unconnected.
- The module package includes a 220 mm long interconnecting cable.

Supported RFID cards 125 kHz:

- EM4x02
- NXP HiTag2

Supported RFID cards 13.56 MHz:

- **ISO14443A** (MIFARE Classic, MIFARE Plus, MIFARE Mini, MIFARE Ultralight, MIFARE DESFire CSN only)
- **PicoPass** (HID iClass CSN, Picopass)
- **FeliCa** (Standard, Lite)
- **ST SR** (SR, SRI, SRIX)
- **HID PAC** (HID SEOS, HID iClass SE, iClass SR, HID MIFARE DESFire with SIO, HID MIFARE Classic with SIO)
- **My2N**
- **2N PICard**



### CAUTION

Press the “key” button on the card reader (without having entered any numbers) on the touch keypad & Bluetooth & RFID card reader module to start Bluetooth authentication.

## Touch Keypad Module

The Touch Keypad module (9155047, 01277-001) is used for numeric access to the system. The numeric touch keypad module helps you dial users via their phonebook positions or phone numbers. Also, it helps you control the lock and other functions via a numeric code. The keypad digits and symbols are backlit.

### Features

- The module contains two bus connectors for the **2N LTE Verso** bus.
- These two connectors are fully interchangeable and can be used either as inputs from the main unit or outputs to other modules.
- If this module is the last one on the bus, one of the connectors remains unconnected.
- The module package includes a 220 mm long interconnecting cable.

## Biometric Fingerprint Reader Module

The Biometric fingerprint reader module (9155045, 01276-001) is used for verification of human fingers for access control and 2N/third party equipment control.



### WARNING

The fingerprint reader may not be installed on places exposed to direct sunlight. If exposed to direct sunlight, the device may report errors.

## Features

- The module contains two bus connectors for the **2N LTE Verso** bus.
- These two connectors are fully interchangeable and can be used either as inputs from the main unit or outputs to other modules.
- If this module is the last one on the bus, one of the connectors remains unconnected.
- The module package includes a 220 mm long interconnecting cable.

Important module properties:

- FBI PIV and Mobile ID certification – FAP20
- durable glass touch surface
- rejection of spoof fingerprints
- operating temperature range: –20 to 55 °C
- 0–90 % relative humidity, noncondensing



### CAUTION

- A higher moisture may deteriorate the finger papillary line scanning. You are advised to dry your finger and the reader scanning surface for successful authentication.
- Fingerprint scanning may be more difficult for seniors whose finger papillary lines are not so distinctive (skin elasticity drops with age and a higher scanning pressure may lead to fingerprint blurring).

## Touch Display Module

The Touch display (9155036, 01275-001) can be used as:

- Infopanel Module – displays the user defined image sequence
- Keypad module – virtual touch keypad
- Button module – virtual phone directory

## Specification

Resolution	320 px x 214 px H x V
Slideshow resolution	214 px x 214 px
Contrast ratio	400
Brightness	350 cd/m <sup>2</sup>
Viewing angle	80 ° from any direction
Weight	280 g

Operating temperature	-20 to +60°C
-----------------------	--------------

---

Resistance level	IK07
------------------	------

## Connectors and Installation

Connection Options:

- The module contains two bus connectors for the **2N LTE Verso** bus.
- These two connectors are fully interchangeable and can be used either as inputs from the main unit or outputs to other modules.
- If this module is the last one on the bus, one of the connectors remains unconnected.
- The module package includes a 220 mm long interconnecting cable.

## 5-Button Module

The 5-Button module (9155035, 01258-001) is used for selected Automation functions. Refer to 2N.com for the printing [template](#).

The buttons are backlit and can include nametags.

## Features

- The module contains two bus connectors for the **2N LTE Verso** bus.
- These two connectors are fully interchangeable and can be used either as inputs from the main unit or outputs to other modules.
- If this module is the last one on the bus, one of the connectors remains unconnected.
- The module package includes a 220 mm long interconnecting cable.

## Specification

Nametag dimensions (W x H)	• 1 button: 52.0 (W) x 15.2 (H) mm (dimensional tolerance: +0; -0.5 mm)
	• 5-button: 57.5 (W) x 89.0 (H) mm (dimensional tolerance: +0; -0.5 mm)

## Keypad Module

The Keypad module (Part No. 9155031/9155031B, 01253-001/01254-001) is used for numeric access to the system.

## Features

- The module contains two bus connectors for the **2N LTE Verso** bus.
- These two connectors are fully interchangeable and can be used either as inputs from the main unit or outputs to other modules.
- If this module is the last one on the bus, one of the connectors remains unconnected.
- The module package includes a 220 mm long interconnecting cable.

## I/O Module

The I/O module (9155034, 01257-001) is used for extending the inputs and outputs. The module is designed for integration of sensors or other devices. The module is installed below another module, i.e. needs no separate position.

## Features

- The module contains two bus connectors for the **2N LTE Verso** bus.
- These two connectors are fully interchangeable and can be used either as inputs from the main unit or outputs to other modules.
- If this module is the last one on the bus, one of the connectors remains unconnected.
- The module package includes a 80 mm long interconnecting cable.
- The inputs / outputs are addressed as follows: <module\_name>.<input/output\_name>, e.g. "module5.relay1". Configure the module name in the Module Name parameter in **Hardware > Extending modules**.

## Connectors and Installation

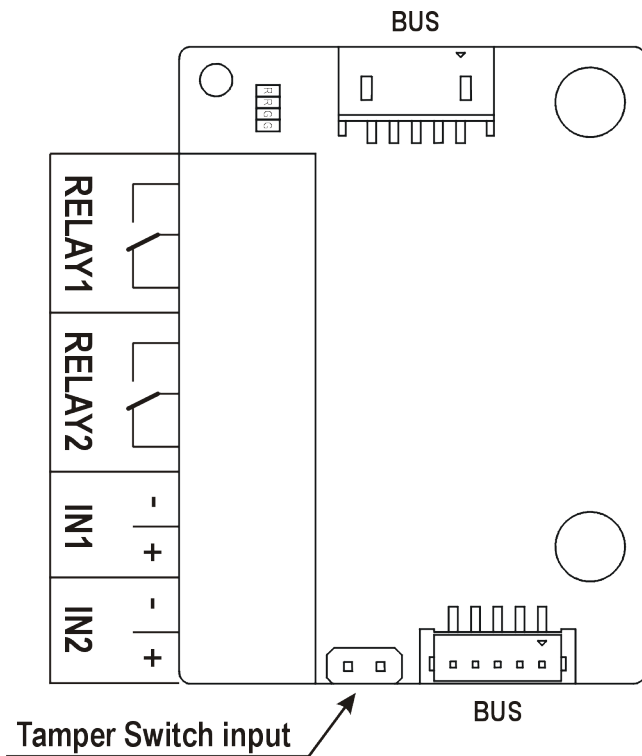

RELAY1/2      RELAY1/2 terminals with accessible 30 V / 1 A AC/DC NO/NC contact

IN1/2          IN1/2 terminals for input in passive / active mode (-30 V to +30 V DC)

- OFF = open or  $U_{IN} > 1.5 \text{ V}$
- ON = short-circuited or  $U_{IN} < 1.5 \text{ V}$

TAMPER        Tamper Switch (9155038, 01260-001) input

The module is installed under another module, i.e. needs no separate position.

1.

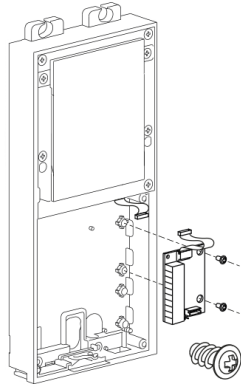

2.

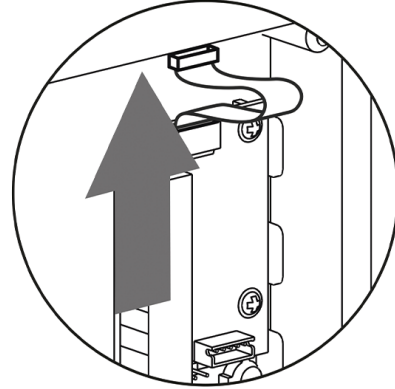

## Wiegand Module

The Wiegand module (9155037, 01259-001) is used for connecting an external Wiegand device (RFID card reader, fingerprint/biometric data scanner) and/or connecting **2N LTE Verso** to an external security exchange.

## Features

- The module contains two bus connectors for the **2N LTE Verso** bus.
- These two connectors are fully interchangeable and can be used either as inputs from the main unit or outputs to other modules.
- If this module is the last one on the bus, one of the connectors remains unconnected.
- The module package includes a 80 mm long interconnecting cable.
- Configure the module name in the Module Name parameter in **Hardware > Extending modules**.
  - LED IN is addressed as follows: <module\_name>.<input1>, e.g. "module2.input1".
  - The Tamper input is addressed as follows: <module\_name>.<tamper>, e.g. "module2.tamper".
  - LED OUT (negated) is addressed as follows: <module\_name>.<output1>, e.g. "module2.output1".

## Specification

### Technical Parameters of Wiegand Input

Current	5 mA
.....	
Input resistance	680 Ω
.....	
Pulse length	50 μs
.....	
Inter-pulse interval	approx. 2 ms

## Connectors and Installation

All the inputs and outputs are galvanically isolated from the device with the insulation strength of 500 V DC. It is necessary to feed +U<sub>IN</sub> on Wiegand W<sub>0OUT</sub> from the Control Panel.

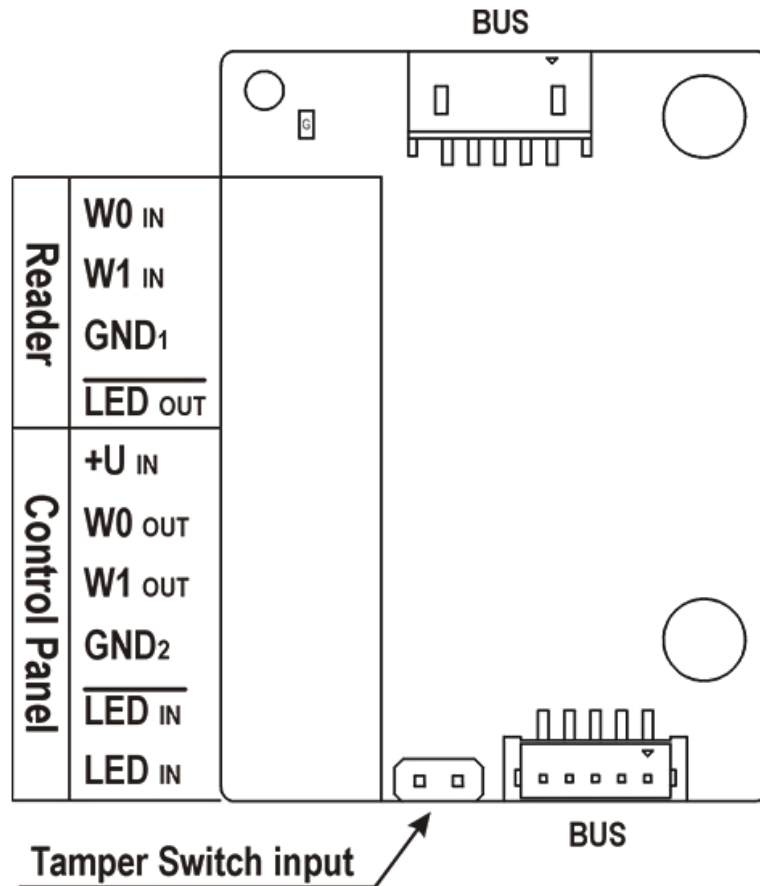

Reader helps connect an external Wiegand-supporting reader. The reader sends the device card ID.

The Control Panel is used for connection to the security PBX / access system to which the device sends the card ID information.

The module contains two BUS connectors for device bus connection. These two connectors are fully interchangeable and can be used either as inputs from the main unit or outputs to other modules.

Reader	W0 <sub>IN</sub> , W1 <sub>IN</sub> , GND <sub>1</sub>	Isolated 2-wire WIEGAND IN
	LED <sub>OUT</sub>	Isolated open LED OUT switched against GND <sub>1</sub> (up to 24 V / 50 mA)

## Main and Extending Modules

Control Panel	+U <sub>IN</sub>	+U <sub>IN</sub> (5 to 15 V DC) for WIEGAND OUT power supply
	W0 <sub>OUT</sub> , W1 <sub>OUT</sub> , GND <sub>2</sub>	Isolated 2-wire WIEGAND OUT
	LED <sub>IN</sub> (nega- ted)	Isolated input for open LED IN, input activated by GND <sub>2</sub> connec- tion
	LED <sub>IN</sub>	Isolated input for open LED IN, input activated after +U connec- tion
	G	+U <sub>IN</sub> WIEGAND OUT active supply LED indicator
	TAMPER	Tamper Switch (9155038, 01260-001) input

The module is installed under another module, i.e. needs no separate position.

1.

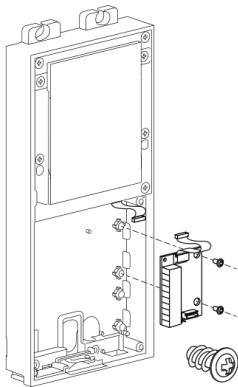

2.

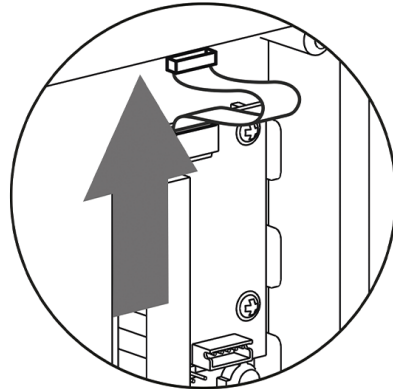

**Recommended Wiegand bus wiring diagram, 2N device as a receiver.**

1. **2N LTE Verso**
2. External RFID Card Reader

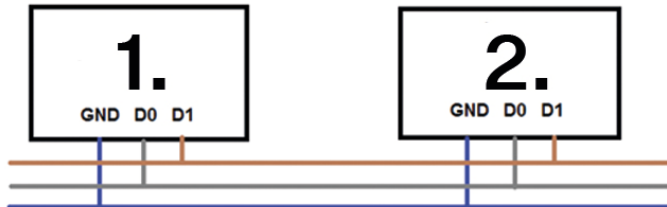

**Recommended Wiegand bus wiring diagram, 2N device as a transmitter.**

1. External RFID Card Reader
2. **2N LTE Verso**

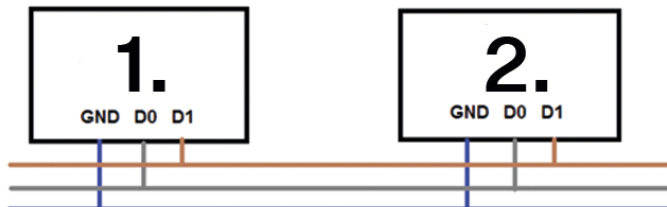

## Recommended reader & OC output wiring diagram

1. **2N LTE Verso**
2. External RFID Card Reader
3. 5 V power supply

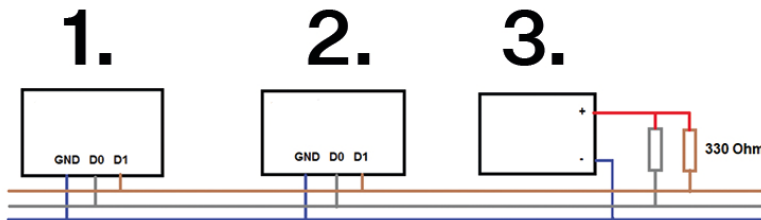

## Security Relay

The Security Relay (9159010, 01386-001) is used for enhancing security between **2N LTE Verso** and the connected electric lock. The Security Relay significantly enhances security of the connected electric lock by preventing unlocking due to device tampering.



### TIP

FAQ: [2N Security Relay – description of the device and use with the 2N intercoms](#)

## Specification

Passive switch      NO/NC contact, up to 30 V / 1 A AC/DC

Switched out-  
put

- Where the Security Relay is fed from the device, 8 to 12 V DC is available on the output depending on the power supply, 400 mA DC.
  - adapter: source voltage of minus 2 V
- Where the Security Relay is fed from an external power supply, 12 V / 700 mA DC is available on the output.

Dimensions      66.5 × 32.5 × 20.5 mm

Weight      24 g

## Connectors and Installation

The Security Relay is installed between the device (outside the secured area) and the electric lock (inside the secured area). The Security Relay includes a relay that can only be activated if a valid access card/code is detected on the unit.

The Security Relay is installed on a two-wire cable between the device and the electric lock inside the area to be secured (typically behind the door). The Security Relay is powered and controlled via this two-wire cable and can thus be added to an existing installation. Thanks to its compact dimensions, the device can be installed into a standard mounting box.

The Security Relay is designed with holes for surface anchoring. It is recommended that a screw of the diameter of 3 mm with a lens head of the diameter of 6 mm is used. Using a countersunk head may cause irreversible damage to the plastic cover!

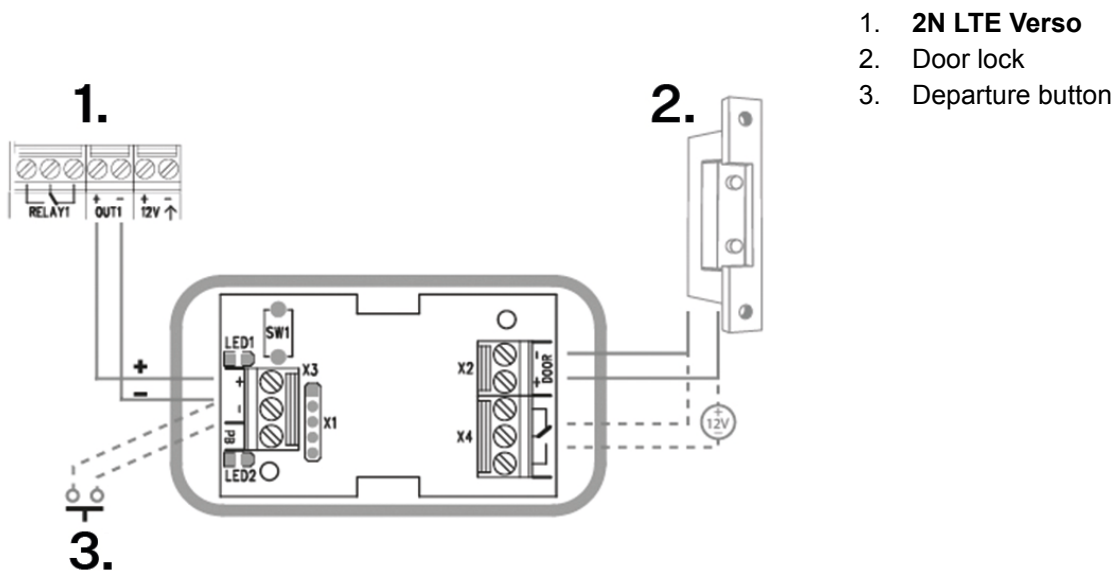

1. **2N LTE Verso**
2. Door lock
3. Departure button

Connect the Security Relay to the access unit as follows:

- To the Active output

Connect the electric lock to the Security Relay as follows:

- to the switched output
- to the passive output in series with the external power supply

The Security Relay also supports the Departure button connected to the 'PB' and '- 2N IP intercom' terminals. Once the Departure button is pressed, the output is activated for 5 seconds.

<https://www.youtube.com/embed/ardukvQzw5A>

## Status Signaling

Green LED	Red LED	State
flashing	off	Operational mode

Green LED	Red LED	State
on	off	Activated output
flashing	flashing	Programming mode – waiting for initialization
on	flashing	Error – wrong code

## Configuration

1. Connect the Security Relay to the properly set Security output of the device. Refer to the Configuration Manual for details. Make sure that one LED at least is on or flashing.
2. Press and hold the Relay RESET button for 5 seconds to switch the device in the programming mode (red and green LEDs flashing).
3. Activate the output switch using the keypad, telephone, etc. The first code sent from the device will be stored in the memory and considered valid. After code initialization, the Security Relay will pass into the operational mode (green LED flashing).



### CAUTION

Having reset the factory defaults on a device with firmware 2.18 or higher, remember to reprogram Security Relay using the instructions above.

## Tamper Switch Module

The Tamper Switch module (9155038, 01260-001) of **2N LTE Verso** is used for securing the system against unauthorized tampering.



### CAUTION

**Remember** to purchase [I/O Module \(p. 118\)](#), [OSDP Module \(p. 128\)](#) or [Wiegand Module \(p. 120\)](#) along with the Tamper Switch.

## Features

The module contains two switches that open whenever the front frame is removed:

- One switch leads directly to the terminal board and is designed for connection to an external security exchange (32 V DC / 50 mA max).
- The other switch, in combination with the [I/O module \(p. 118\)](#), [OSDP module \(p. 128\)](#) or [Wiegand module \(p. 120\)](#), can be used for alarm triggering via the Automation interface in the **2N LTE Verso** configuration.

## Connectors and Installation

This module is not connected to the bus.

## Main and Extending Modules



Jumpers are used for interconnecting the Tamper Switch pins with the I/O / OSDP / Wiegand module.

1.

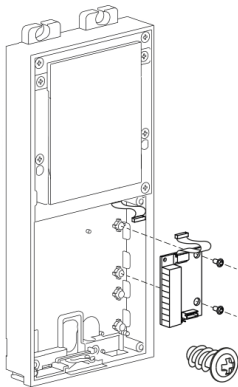

2.

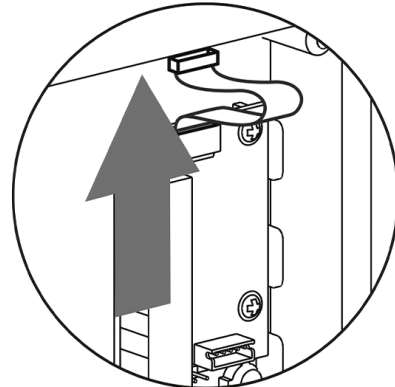

3.

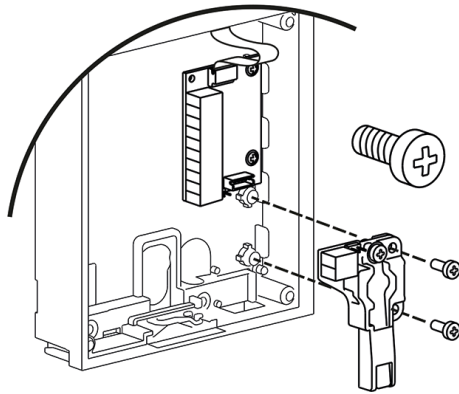

4.

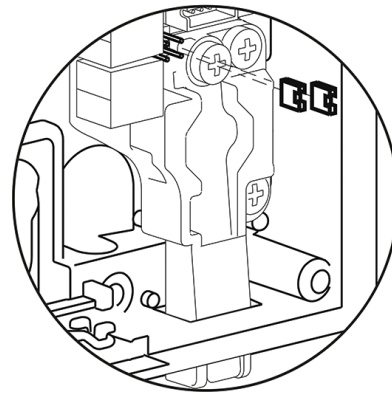

## OSDP Module

The OSDP module (91550371, 02577-001) of **2N LTE Verso** provides OSDP communication between a connected OSDP device (control panel, door controller) and the device. The OSDP module provides secure sending of such access data as the access card ID or PIN code.

## Features

- The module contains two bus connectors for the **2N LTE Verso** bus.
- These two connectors are fully interchangeable and can be used either as inputs from the main unit or outputs to other modules.
- If this module is the last one on the bus, one of the connectors remains unconnected.
- The module package includes a 80 mm long interconnecting cable.

The module also includes:

- Isolated OSDP bus
- Power and pairing mode signaling LED
- Tamper Switch (9155038, 01260-001) input

## Connectors and Installation

All the inputs and outputs are galvanically isolated from **2N LTE Verso** with the insulation strength of 1500 V DC.



2. Connect the OSDP device as instructed (A to B or B to A) keeping the correct order to avoid malfunction.



**CAUTION**

- Mounting jumpers JP2 and JP3 results in a connection of strong pull-up/pull-down resistors (560 ohms) to the RS-485 bus. These jumpers must be mounted/unmounted together, i.e. one jumper cannot be mounted alone. Strong pull-up and pull-down resistors can be connected only and exclusively to one arbitrary device on the OSDP bus.
- Mounting JP4 results in a connection of the terminating 120 ohm resistor between wires A and B of the OSDP bus. The terminating resistors may be connected exclusively on the first and last modules on the OSDP bus. We recommend the connection of these resistors on the first and last modules.

1.

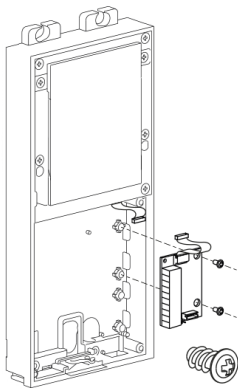

2.

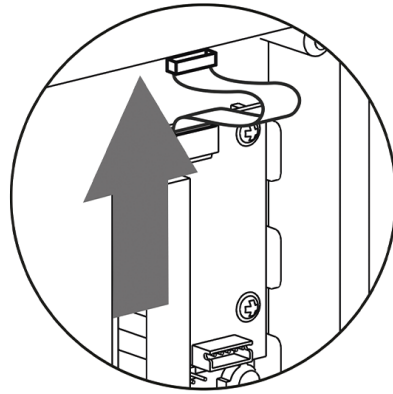

## Connection Recommendations

### Wiring diagram for two-wire connection

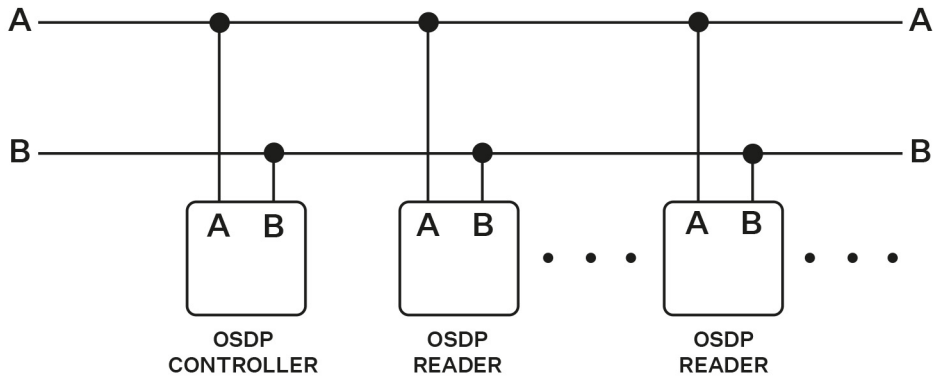

### Wiring diagram for three-wire connection

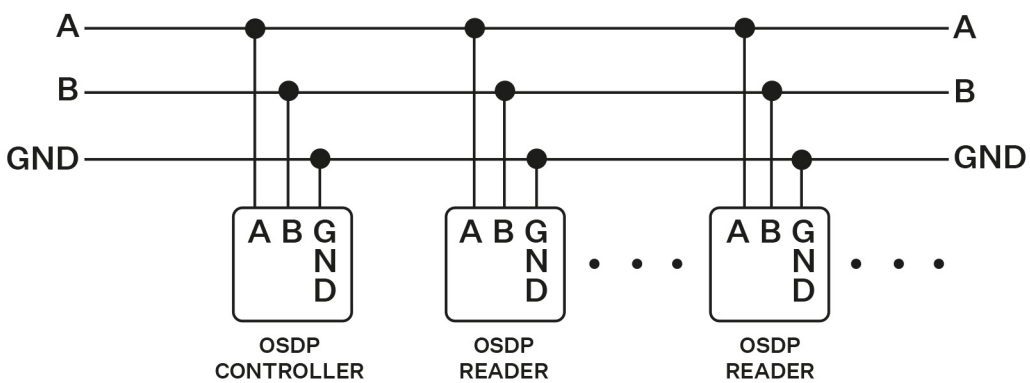

## Configuration

Having logged in to the device web interface, use the **Hardware > Extending modules** menu to set the following:

1. Name the module for user identification (optional).
2. Choose a group for access data resending, making sure that the settings are identical with those of the access readers from which the data are to be resent (card ID, PIN).
3. The setting of the codes to be transmitted is optional.
4. Enter the OSDP address between 0 and 126 to set the OSDP module address on the OSDP line.
5. Set the communication rate in accordance with the requirements of the device to be connected.
6. Enter your own encryption key into **2N LTE Verso** and the opponent's device to ensure encrypted communication.
7. Enable forced encryption just for encrypted communication.

Any unencrypted communication from the OSDP device will be rejected if forced encryption is enabled.

If the OSDP device enables remote encryption key setting on a peripheral, you can use the installation mode. Once the encryption key is received, the common mode is automatically switched on. The installation mode is signaled by a LED fast flashing on the OSDP module.

## Induction Loop Module

The Induction Loop module (9155041, 01263-001) on **2N LTE Verso** is used for transmitting audio signals via the magnetic field directly into the hearing aids.

## Features

- The module contains two bus connectors for the **2N LTE Verso** bus.
- These two connectors are fully interchangeable and can be used either as inputs from the main unit or outputs to other modules.
- If this module is the last one on the bus, one of the connectors remains unconnected.
- The module package includes a 220 mm long interconnecting cable.

## Specification

Used mode	T
Maximum power	2 W
Frequency range	100 Hz – 5 kHz / $\pm$ 3 dB
Antenna output short circuit resistance	without restriction

## Infopanel Module

The Infopanel module (9155030, 0159-7891) is used for inserting and backlighting printed information. It helps place a company logo or opening hours, e.g., to the device. The Infopanel is backlit, the backlight is software controlled. Refer to [2N.com](http://2N.com) for the printing template.

## Features

- The module contains two bus connectors for the **2N LTE Verso** bus.
- These two connectors are fully interchangeable and can be used either as inputs from the main unit or outputs to other modules.

## Main and Extending Modules

- If this module is the last one on the bus, one of the connectors remains unconnected.
- The module package includes a 220 mm long interconnecting cable.

### Specification

Nametag dimensions (W x H)                      69.2 x 86.7 mm (tolerance: +0; -0.5 mm)

### Blind Panel Module

The Blind panel module (Part Nos. 9155039, 01261-001) is used for occupying an empty position.

# Brief Guidelines

## Device Configuration Interface Access

**2N LTE Verso** is configured via a web configuration interface. You have to know the device IP address for access, which is possible only if the public IP address service is active on the SIM card. The default web configuration interface access option is the My2N portal.

**2N LTE Verso** automatically connects to the My2N portal after logging into the LTE mobile data network. Log in to My2N at <https://my2n.com> by adding the device to your account. The 2N Mobile Video service helps you make basic settings and set up calls to mobile phones or 2N answering units. The 2N Remote Configuration service also makes the device web configuration interface available.

## Web Configuration Interface Login

1. Enter the public IP address if available into your Internet browser.

The login screen is now displayed.

Should the login screen fail to appear, make sure that you have typed the correct IP address, port or domain name. The login screen also does not appear when the administration web server is off. If you do not have a certificate generated for the IP address / domain name, an invalid security certificate warning may be displayed. In this case, you have to confirm that you want to go to the web configuration interface.

2. Enter the login data.

The default login data are:

Username: **Admin**

Password: **2n**

It is necessary to change the password immediately upon the first login.

After login using the default password, the access to the web configuration interface functions is limited.



### TIP

It is recommended that a password is used that is difficult to break. It is not recommended that names, places or things, especially those closely related to the user, are used in the password.

For increased password security, it is recommended that:

- the random password generator is used,
- the password length is 12 characters at least,
- various characters from different character sets are combined (small/capital letters, digits, special characters, etc.).

## Recommended browsers

The web configuration interface is optimized for the Chromium-based web browsers (Google Chrome, Microsoft Edge or Opera, e.g.). With other browsers, there may be slight differences in the interface function and appearance.

## Configuration via Hardware

Where software configuration is unavailable, make basic settings using the RESET button (refer to [Device Connectors \(p. 97\)](#)).

The RESET button helps you reset the factory default values, restart the device, retrieve the device IP address and switch the IP address static/dynamic mode.

### Device Restart

Press the button shortly (< 1 s) to restart the system without changing configuration.

### Factory Default Reset with RESET Button

1. Press the button RESET and keep it pressed.
  - a. Wait until the red and green LEDs go on simultaneously on the device and the acoustic signal can be heard 🎵 (approx. 15–35 s).
  - b. Wait until the red LED goes off and an acoustic signal can be heard 🎵 (approx. for another 3 s).
  - c. Wait until the green LED goes off and the red LED goes on again and an acoustic signal can be heard 🎵 (approx. for another 3 s).
  - d. Wait until the red LED goes off and the acoustic signal can be heard 🎵 (approx. for another 3 s).
2. Release the RESET button.

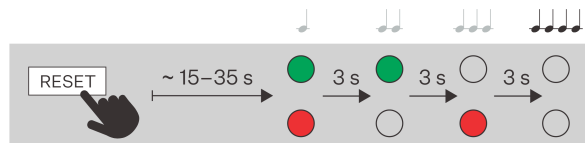

## Firmware Update

We recommend that the firmware is also updated during the **2N LTE Verso** installation. Refer to [2N.com](#) for the latest FW version.

Update firmware via the web configuration interface in System > Maintenance, refer to the device Configuration Manual.

Once the firmware is uploaded successfully, the device is restarted automatically.



#### TIP

You can make bulk updates for multiple devices via 2N Access Commander.

## Device Restart

To restart the device choose one of the following options:

- using the RESET button,
- using disconnection from the power supply,
- via the web configuration interface.

**NOTE**

The device restart does not result in any change in the configuration settings.

**Restart Using RESET Button**

Press the button shortly (< 1 s) to restart the system without changing configuration.

**Restart Using Web Configuration Interface**





You can restart the device via the web configuration interface. Refer to [Web Configuration Interface Login \(p. 134\)](#) for login details. Restart the device in System > Maintenance > System using [Restart device](#).

**Factory Default Reset with RESET Button**

Reset the device factory default values via software in System > Maintenance > Default reset.

Follow the instructions below **2N LTE Verso** to reset the factory default values via hardware:

**Factory Default Reset with RESET Button**

1. Press the button RESET and keep it pressed.
  - a. Wait until the red and green LEDs go on simultaneously on the device and the acoustic signal can be heard  (approx. 15–35 s).
  - b. Wait until the red LED goes off and an acoustic signal can be heard  (approx. for another 3 s).
  - c. Wait until the green LED goes off and the red LED goes on again and an acoustic signal can be heard  (approx. for another 3 s).
  - d. Wait until the red LED goes off and the acoustic signal can be heard  (approx. for another 3 s).
2. Release the RESET button.

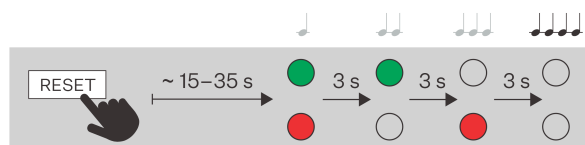
**CAUTION**

In case the factory default values are reset on the device with a firmware version 2.18 or higher, it is necessary to reprogram the 2N Security Relay using the instructions given in [Security Relay \(p. 124\)](#).

# Device Control

**2N LTE Verso** is an intercom allowing you to:

- call other devices
  - use quick dial buttons
  - dial phone book position
  - dial phone number
- receive and reject incoming calls
- activate switch (e.g. door opening, lift control, etc.)

The device works as an authorization intermediary, which authenticates the user access rights and, if the user access is valid, activates the switch. The door lock, lifts etc. can be controlled by the switch.

The device control depends on the product version:

- using RFID cards and chips – by tapping a card/chip on the device,
- using the **2N My2N** application – by pressing the device touchscreen in the vicinity of a mobile device with **2N My2N** logged in,
- using NFC,
- using biometric data (fingerprint)
- by entering a numeric access code via a keypad , touch keypad or in the 2N My2N application
- control the device using a touch display
- activate/deactivate users or profiles using the **2N My2N** mobile application

## Speed Dial Buttons

By pressing the speed dial button on the main unit, you can make a quick call to the assigned position in the phone book, see the Intercom Configuration > Calling > Dialing chapter in the Configuration Manual.

Use extending modules to extend the number of quick dial buttons to up to 146.

Call setup is signaled by a long intermittent tone or otherwise as configured in the PBX connected.

Pressing the same button repeatedly during or while making a call can be assigned the function of hanging up or hanging up simultaneously with a call to the next phone number of the called party. Alternatively, pressing the same button repeatedly may have no function, see **Intercom Configuration > Calling > General Settings** in the Configuration Manual.

For keypad equipped models, you can also hang up the call at any time by pressing  if enabled so by the Button function during an outgoing call parameter, see **Intercom Configuration > Calling > General Settings** in the Configuration Manual.



## Calling to Phone Book Position

The Phonebook **2N LTE Verso** can contain up to 10 000 pre-programmed positions. Depending on the number of speed dial buttons actually installed, you can call a given number of positions in the phone book. The remaining positions can be retrieved via the numeric keypad if the **Speed dial using digits** is enabled in configuration.

1. Enter the position number using your numeric keypad (05, 15, 200 e.g. – two digits at least and four digits at most) and press  for confirmation.

- For keypad equipped models, you can also hang up the call at any time by pressing  if enabled so by the Button function during an outgoing call parameter, see **Intercom Configuration > Calling > General Settings** in the Configuration Manual.

## Incoming Call Answering/Rejecting

If the automatic incoming call answering function is turned off, an incoming call is signaled by a loud ringing tone. Push the  button to answer the call and the  button to reject the call.

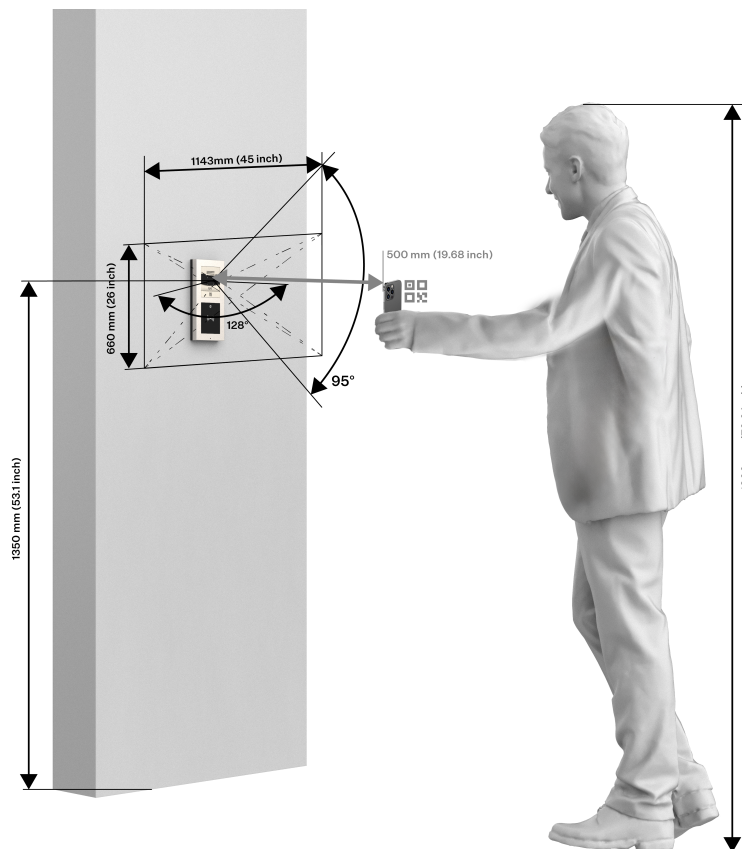

## Switch-Off Using QR Code

The visualization below shows the (range of the) field of view and optimum installation height for the device camera. It is recommended that the QR code is placed 50 cm in front of the camera for optimum reading.



## Door Opening (Switch Activation) by Code

**2N LTE Verso** is equipped with a door unlocking switch. Enter the valid code (refer to Subs. [Switches](#) of the Configuration Manual for IP Intercoms) using the numeric keypad to activate this switch.

- Enter the switch activating numeric code using the numeric keypad and press the  button for confirmation.
- A valid code is notified visually and by a continuous switch activation tone or a predefined unlocking user sound. An invalid code or interruption longer than as defined in **Timeout for Entering Numbers** is signaled acoustically  or using a user sound.

## Door Opening (Switch Activation) by Biometric Reader

The Fingerprint reader is used for verification of human fingers for access control and intercom control. Refer to the Directory > [Users](#) subsection in the Configuration Manual for IP Intercoms for how to load a fingerprint into a user profile.

1. Apply your finger to the reader scanning area.
2. Reader authentication light signalling indicates the status of:
  - **Green** – the fingerprint has been recognised successfully.
  - **Green flashes to red** – the fingerprint has been recognised but access is denied. Check the user time profile setting state and multiple authentication setting. Access can also be blocked by a previous tamper switch blocking.
  - **Red** – the fingerprint has not been recognised.



**CAUTION**

A higher moisture may deteriorate the finger papillary line scanning. You are advised to dry your finger and the reader scanning surface for successful authentication.

## LED pictograms

The following photo shows the location of the elements on the front of the device.

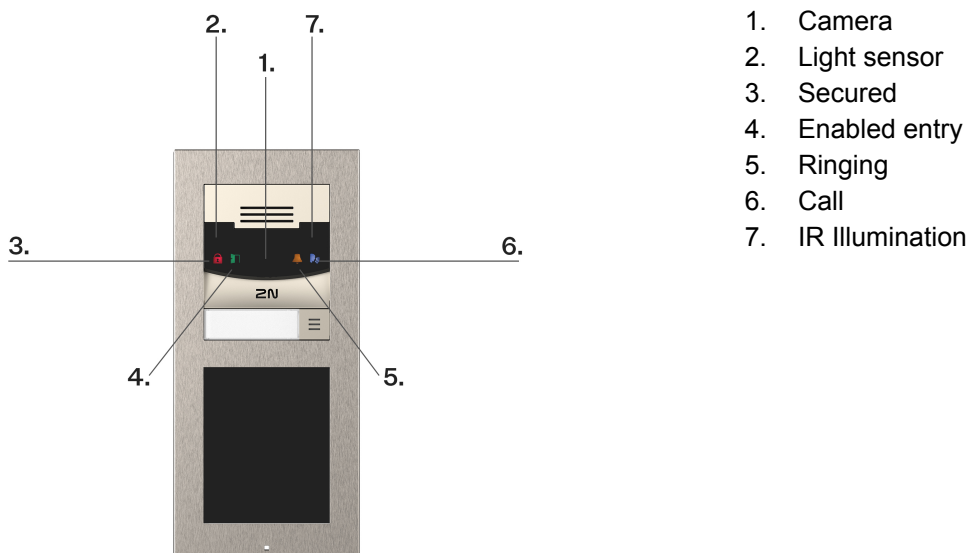

1. Camera
2. Light sensor
3. Secured
4. Enabled entry
5. Ringing
6. Call
7. IR Illumination

## Device Configuration via SMS Commands

**2N LTE Verso** is equipped with an implemented set of SMS commands, which is used for retrieving the device state and setting the basic mobile data connection parameters. If, e.g., an APN other than that automatically selected upon the first device start is to be set, the appropriate SMS command can be used.

Make sure that all the SMS commands are admin authorized via “pwd=<password>”. The password always matches the web configuration interface login password. If the password is missing or invalid, the device ignores the command and fails to process the data and respond. Make sure that the device is logged into the LTE network to make the device work properly. However, the SMS commands work without data connection too.

### Find the current device state – STATE command

SMS command format – “state pwd=<password>” – e.g. “state pwd=2n”

The device sends the following response:

Info	Description
state: REGISTERED	device is currently logged into mobile network without data connection
state: DATA_CONNECTING	device is currently logged into mobile network trying to establish data connection
state: DATA_CONNECTED	device is currently logged into mobile network with established data connection
provider	provider to which the device is connected
network: NONE	device has currently no data connection
network: 2G	device is currently connected to 2G network
network: 3G	device is currently connected to 3G network
network: 4G	device is currently connected to 4G network
signal	signal strength
ipaddr	device IP address

### Read parameter – GET command

SMS command format – “get pwd=<password> <parameter>” – e.g. “get pwd=2n fwver”

The device sends the following response: “ok <parameter>=<value>” or “error” including error description.

Available Command Parameters

Parameter	Description
name	device name
my2nid	My2N ID
serial	device serial number

Parameter	Description
apn	APN, parameters ausr and apwd are returned in the response
ausr	APN authorization name
apwd	APN authorization password
iccid	SIM card ICCID
fwver	current firmware version

### Set parameter – SET command

SMS command format – “set pwd=<password> <parameter>=<value>” – e.g. “set pwd=2n name=Bra-na01”, “set pwd=2n http=1”

The device sends the following response: “ok” or “error” including error description.

Available Command Parameters

Parameter	Description
name	device name
my2nid	My2N ID
http	HTTP server switch on/off

### Set APN parameter – SET command

SMS command format – “set pwd=<password> apn=<apnName> ausr=<apnUser> apwd=<apnPwd>” – e.g. “set pwd=2n apn=internet.t-mobile.cz ausr=wap apwd=wap”, “set pwd=2n apn=internet ausr= apwd=”

Available Command Parameters

APN Parameters	Description
apnName	name of APN to mobile provider
apnUser	username to APN

APN Parameters	Description
apnPwd	APN password

**Device beeps and flashes after receiving the command – LOCATE command**

SMS command format – “locate pwd=<password>” – e.g. “locate pwd=2n”

The device sends the following response: “ok”.

## Maintenance - Cleaning

**2N LTE Verso** contains no environmentally harmful components. Dispose of the device in accordance with the applicable legal regulations.

If used frequently, the device surface gets dirty. Use a piece of soft cloth moistened with clean water to clean the device. Use appropriate cleaning agents suitable for glasses, optical devices, screens, etc. We recommend that IT cleaning wipes are used.



### CAUTION

Use the product for the purposes it was designed and manufactured for, in compliance herewith. The manufacturer reserves the right to modify the product in order to improve its qualities.

If used frequently, the device surface gets dirty. Use a piece of soft cloth moistened with clean water to clean the device. Use appropriate cleaning agents suitable for glasses, optical devices, screens, etc. We recommend that IT cleaning wipes are used.

- Do not use aggressive and alcohol/peroxide based detergents.
- For cleaning the glass lens, use suitable cleaning agents designed for cleaning glasses, optics, screens, etc.
- Prevent water from getting inside the device.



### TIP

To disinfect the surface of the device against bacteria and viruses (Anti-Covid) and maintain the hygienic conditions of critical surfaces and touch points, we recommend that you use the Zoono – Microbe Shield Surface Sanitiser spray.

# Troubleshooting

Refer to <https://www.2n.com/faqs> for the most frequently solved problems.

# Technical Parameters

## Power supply types

External supply                      12 V  $\pm$ 15 % / 2 A DC (3 A for multiple modules)

## Signaling protocol

SIP    UDP, TCP, TLS

## Buttons

Button design    Transparent, white backlit buttons with easily replaceable nametags

Button count    1 to multiples of 5 (depending on the configuration)

Button extenders    Up to 29 modules (limited by power supply)

Numeric Keypad    Optional

## Audio

Microphone    Integrated

Amplifier    2 W (class D)

Speaker    2 W / 8  $\Omega$

Sound pressure level (SPL max)    78 dB (for 1 kHz, distance 1 m)

## Technical Parameters

### Audio

LINE OUT	1 VRMS / 600 $\Omega$
Volume Control	Adjustable with automatic adaptive mode
Full duplex	Yes (AEC)

### Audio stream

Protocols	<ul style="list-style-type: none"><li>• RTP</li><li>• SRTP</li></ul>
Codecs and Used Bandwidth	<ul style="list-style-type: none"><li>• G.711 (PCMA, PCMU) – 64 kbps (with 85.6 kbps headers)</li><li>• G.729 – 16 kbps (with 29.6 kbps headers)</li><li>• G.722 – 64 (with 85.6 kbps headers)</li><li>• L16/16kHz – 256 kbps (with 277.6 kbps headers)</li></ul>

### Camera

Sensor	1/3" color CMOS
JPEG resolution	Up to 1280 x 960
Video resolution	640 x 480
Frame rate	30 fps
Sensor sensitivity	5.6 V/lux-sec (550 nm)
Viewing angle	125° (H), 105° (V)
Infrared illumination	Yes
Sensor sensitivity without IR light	0.1 Lux $\pm$ 20 %

## Technical Parameters

### Camera

Focal length 2.25 mm

### Video stream

Protocols

- RTP
- RTSP
- HTTP

Video call codecs

- H.263
- H.264

Set the video codec data flows in **Services > Phone > Video** for calls and in **Services > Streaming > RTSP** for streaming. The set bit rate represents the value that the codec has to approach on a long-time average. The data flow can vary depending on the scene to be scanned.

ONVIF/RTSP streaming codecs

- H.264
- MPEG-4
- MJPEG

IP Camera Function

Yes – compatible profiles:

- ONVIF v2.4 profile S

### External antenna

Connector MMCX

Gain 4.1 dB

Power Supply 25 W

Operating temperature -40 to +80°C

**External antenna**

Dimensions	<p>Maximum values:</p> <ul style="list-style-type: none"> <li>• height: 6 mm</li> <li>• width: 14 mm</li> <li>• length: 122 mm</li> </ul>
------------	---

Installation	With adhesive tape
--------------	--------------------

**Bandwidth used**

Audio codecs	<ul style="list-style-type: none"> <li>• PCMA, PCMU – 64 kbps (with 85.6 kbps headers)</li> <li>• G.729 kbps – 16 bps (with 29.6 kbps headers)</li> <li>• G.722 – 64 kbps (with 85.6 kbps headers)</li> <li>• L16 / 16 kHz – 256 kbps (with 277.6 kbps headers)</li> </ul>
--------------	--

Video Codecs	<p>Set the video codec data flows for calls in <b>Services &gt; Calls &gt; SIP 1/2</b>. Set streaming in <b>Services &gt; Streaming &gt; RTSP</b>. The set bit rate represents the value that the codec has to approach on a long-time average. The data flow can vary depending on the scene to be scanned.</p>
--------------	--

**Interface**

Passive switch (relay)

Active switch output	<p>8 to 12 V DC according to power supply, up to 400 mA</p> <ul style="list-style-type: none"> <li>• adapter: source voltage –2 V</li> </ul>
----------------------	--

LTE FFD	Cat.1, 3GPP
---------	-------------

Passive / active input	–30 V to +30 V DC
------------------------	-------------------

**Interface**

EU LTE bandwidths

Part Nos. **9155401C-E, 9155401CB-E**

**Telit LE910-EU1 module**

- LTE bandwidths:
  - B1 (2100 MHz)
  - B3 (1800 MHz)
  - B7 (2600 MHz)
  - B8 (900 MHz)
  - B20 (800 MHz)

US LTE bandwidths

Part Nos. **9155401C-U1, 9155401CB-U1**

**Telit LE910-NA1 module**

- LTE bandwidths:
  - B2 (1900 MHz)
  - B4 (AWS 1700 MHz)
  - B5 (850 MHz)
  - B12/B13 (700 MHz)
- UMTS bandwidths:
  - B2 (1900 MHz)
  - B5 (850 MHz)
- Connection rate:
  - Uplink up to 5 Mbps
  - Downlink up to 10 Mbps

**Bluetooth**

Bluetooth

in compliance with BLE (Bluetooth Low Energy)

Security

Encoding:

- asymmetric RSA-1024
- symmetric AES-128

Range

Adjustable:

- short ~ 0.5 m
- medium ~ 2 m
- long ~ up to 10 m

RX sensitivity

up to -93 dBm

Consumption

20 mA at 12 V DC

## Technical Parameters

### Bluetooth

Operating temperature	-40 °C ~ +60 °C
Storing temperature	-40 °C ~ +70 °C
Dimensions	97 x 105 x 30 mm
Support of mobile applications	Android 10.0 and higher, iOS 17.0 and higher

### Touch Display Module

Resolution	78 dB (for 1 kHz, distance 1 m)
Slideshow mode resolution	214 × 320 px, 214 x 214 px
Contrast ratio	400 : 1
Brightness	78 dB (for 1 kHz, distance 1 m)
Viewing angle	80° from all directions
Weight	280 g
Minimum consumption	1.36 W
Maximum consumption	2.40 W
Operating temperature	-20°C to 60°C
Resistance level	IK07
Directory	residential / business (for 10 000 users)

## Technical Parameters

### I/O module, Wiegand module

Dimensions 43 x 31.5 x 1.5 mm

### Mechanical Parameters

Cover Robust zinc casting with surface finish (minor surface shade nuances are acceptable).

Body material

Versions:

- Light version - Nickel:
  - Material - Zamak 410 - Zn95Al4Cu1
  - Surface treatment - Zn/Cu20/Ni25b max. 80 µm

Surface installation dimensions	One-module	107 x 130 x 28 mm
---------------------------------	------------	-------------------

Two-module	107 x 234 x 28 mm
------------	-------------------

Flush installation dimensions	Frame – one-module	130 x 153 x 5 mm
-------------------------------	--------------------	------------------

Frame – two-module	130 x 257 x 5 mm
--------------------	------------------

Box (minimum wall hole) – one-module	108 x 131 x 45 mm
--------------------------------------	-------------------

Box (minimum wall hole) – two-module	108 x 238 x 45 mm
--------------------------------------	-------------------

Weight (depending on configuration)	Max. net	2 kg
-------------------------------------	----------	------

Max. gross	2.5 kg
------------	--------

Operating temperature -40 °C to 60 °C

## Technical Parameters

### Mechanical Parameters

---

Relative humidity	10 to 95 % (non-condensing)
-------------------	-----------------------------

---

Storing temperature	-40 °C to 70 °C
---------------------	-----------------

---

Protection class	IP54
------------------	------

---

Resistance level	IK08
------------------	------

## General Instructions and Cautions

Please read this User Manual carefully before using the product and follow the instructions and recommendations included therein.

Any use of the product that is in contradiction with the instructions provided herein may result in malfunction, damage or destruction of the product.

The manufacturer shall not be liable and responsible for any damage incurred as a result of a use of the product other than that included herein, namely undue application and disobedience of the recommendations and warnings.

Any use or connection of the product other than those included herein shall be considered undue and the manufacturer shall not be liable for any consequences arisen as a result of such misconduct.

Moreover, the manufacturer shall not be liable for any damage or destruction of the product incurred as a result of misplacement, incompetent installation and/or undue operation and use of the product in contradiction herewith.

The manufacturer assumes no responsibility for any malfunction, damage or destruction of the product caused by incompetent replacement of parts or due to the use of reproduction parts or components.

The manufacturer shall not be liable and responsible for any loss or damage incurred as a result of a natural disaster or any other unfavorable natural condition.

The manufacturer shall not be held liable for any damage of the product arising during the shipping thereof.

The manufacturer shall not make any warrant with regard to data loss or damage.

The manufacturer shall not be liable and responsible for any direct or indirect damage incurred as a result of a use of the product in contradiction herewith or a failure of the product due to a use in contradiction herewith.

All applicable legal regulations concerning the product installation and use as well as provisions of technical standards on electric installations have to be obeyed. The manufacturer shall not be liable and responsible for damage or destruction of the product or damage incurred by the consumer in case the product is used and handled contrary to the said regulations and provisions.

The consumer shall, at its own expense, procure software protection of the product. The manufacturer shall not be held liable for any damage incurred as a result of the use of deficient security software.

The consumer shall, without delay, change the access password for the product after installation. The manufacturer shall not be held liable or responsible for any damage incurred in connection with the use of the original password.

The manufacturer also assumes no responsibility for additional costs incurred by the consumer as a result of making calls to increased tariff lines.

### Directives, Laws and Regulations

**2N LTE Verso** conforms to the following directives and regulations:

#### EU

- 2012/19/EU on waste electrical and electronic equipment

- 2014/53/EU for radio equipment
- 2011/65/EU on the restriction of the use of certain hazardous substances in electrical and electronic equipment

### **Industry Canada**

This Class B digital apparatus complies with Canadian ICES-003/NMB-003.

### **Compliance with DDA:**

The 2N Telekomunikace devices comply with the Disability Discrimination Act (DDA) of 2005 stipulating the following conditions:

1. The devices are mounted in such a manner that their bottom edges are 100 to 120 centimeters above the ground.
2. The devices use keypads with a mechanical protrusion on digit 5.
3. The devices use an electromagnetic loop as the hearing aid.

### **Electric Waste and Used Battery Pack Handling**



Do not place used electric devices and battery packs into municipal waste containers. An undue disposal thereof might impair the environment!

Deliver your expired household electric appliances and battery packs removed from them to dedicated dumpsites or containers or give them back to the dealer or manufacturer for environmental-friendly disposal. The dealer or manufacturer shall take the product back free of charge and without requiring another purchase. Make sure that the devices to be disposed of are complete.

Do not throw battery packs into fire. Battery packs may not be taken into parts or short-circuited either.



2N LTE Verso – Installation Manual

© 2N Telekomunikace a. s., 2026

**2N.com**