



# 2N Access Unit M

Installation Manual



# Table of Contents

<b>Symbols and Terms Used</b> .....	<b>4</b>
<b>Product Description</b> .....	<b>5</b>
Basic Features .....	5
Product Versions .....	6
Accessories .....	8
Accessories for Installation .....	8
Extenders .....	9
Power Supply .....	9
Other accessories .....	10
Package Completeness Check .....	14
Package Completeness Check for Installation Accessories .....	15
<b>Installation</b> .....	<b>16</b>
Mechanical Installation .....	16
Surface Installation .....	17
Surface installation on mounting backplate .....	19
Flush mounting .....	21
Electric Installation .....	24
Power Supply .....	24
Cabling Description .....	27
Cable Connection .....	29
LAN Connection .....	29
Overvoltage Protection .....	30
<b>Brief Guidelines</b> .....	<b>33</b>
IP Address Retrieval .....	33
IP Address Retrieval Using 2N IP Utility .....	33
IP Address Retrieval Using the RESET button .....	34
Access to web device configuration .....	35
Password Change .....	35
Recommended browsers .....	36
Firmware Update .....	36
Device Restart .....	36
Restart Using RESET Button .....	37
Restart Using Web Configuration Interface .....	37
Factory Default Reset .....	37
Factory Default Reset with RESET Button .....	37
Configuration via Hardware .....	38
Device Restart .....	38
IP Address Retrieval Using the RESET button .....	38
Static IP Address Setting with RESET Button .....	38
Dynamic IP Address Setting via RESET .....	39
Factory Default Reset with RESET Button .....	40
<b>Device Control</b> .....	<b>41</b>
Signaling of Operational Statuses .....	41
<b>Maintenance - Cleaning</b> .....	<b>42</b>
<b>Troubleshooting</b> .....	<b>43</b>
<b>Technical Parameters</b> .....	<b>44</b>
<b>General Instructions and Cautions</b> .....	<b>47</b>
Directives, Laws and Regulations .....	47
EU .....	47
Industry Canada .....	48
Legislation of Thailand .....	48



## Symbols and Terms Used

The following symbols and pictograms are used in the manual:



**DANGER**

**Always abide** by this information to prevent persons from injury.



**WARNING**

**Always abide** by this information to prevent damage to the device.



**CAUTION**

**Important information** for system functionality.



**TIP**

**Useful information** for quick and efficient functionality.



**NOTE**

Routines or advice for efficient use of the device.

# Product Description

In this section, we introduce the **2N Access Unit M** product, outline its application options and highlight the advantages following from its use.

## Basic Features

**2N Access Unit M** is an elegant and reliable IP system equipped with a number of useful functions. **2N Access Unit M** is designed as a robust, mechanically resistant access system, which withstands any weather conditions without requiring additional accessories.

**2N Access Unit M** is a single-module access system available in several versions. All the versions include an integrated card reader module, which helps control access using an RFID card. With additional software settings, functions other than the door lock switch can be RFID card controlled too.

The **2N Access Unit M** keypad version helps you control the electric lock switch by entering a valid numeric code via the numeric keypad. With additional software settings, functions other than the door lock can be RFID card controlled too.

The **2N Access Unit M** Bluetooth version helps you control the lock switch using the **2N My2N** application installed in your smartphone. **2N Access Unit M** is designed as a resistant IP55-rated access system, which withstands any weather conditions without requiring additional accessories.

The installation of **2N Access Unit M** is very easy. All you have to do is connect the system to your LAN via a mains cable. Feed the device from a 12 V power supply or your PoE supporting LAN.

Use a PC equipped with any internet browser to configure **2N Access Unit M**. extensive access system installations easily.

Advantages of Use **2N Access Unit M**:

- Elegant mullion design,
- Cover rating,
- Variable installation options (flush mounting into brick/plasterboard walls, surface installation, door frame mounting),
- Integrated electric lock switches with wide setting options,
- Integrated RFID card reader module,
- Bluetooth module version or backlit touch keypad,
- Configuration using web interface,
- HTTP server for API configuration,
- SNTP client for server time synchronization,
- SMTP client for e-mail sending,
- TFTP/HTTP client for automated configuration and firmware update,
- LAN (PoE) or external 12 V power supply.

## Product Versions



### Part No. 9161121

Axis Part No. 02909-001

2N Access Unit M 13.56 MHz, NFC ready

Combining an access reader and a controller, the device is used for access control inside and outside of buildings.

The device is used for reading RFID cards in the 13.56 MHz bandwidth with the NFC support.

It is a 3m LAN cable version.

Supported RFID cards 13.56 MHz:

- **ISO14443A** (MIFARE Classic, MIFARE Plus, MIFARE Mini, MIFARE Ultralight, MIFARE DESFire CSN only)
- **PicoPass** (HID iClass CSN, Picopass)
- **FeliCa** (Standard, Lite)
- **ST SR** (SR, SRI, SRIX)
- **My2N**
- **2N PICard**



### Part No. 9161141

Axis Part No. 02910-001

2N Access Unit M RFID – 125 kHz, 13.56 MHz, NFC

Combining an access reader and a controller, the device is used for access control inside and outside of buildings.

The device is used for reading RFID cards in the 125 kHz and 13.56 MHz bandwidths with the NFC support.

It is a 3m LAN cable version.

Supported RFID cards 125 kHz:

- EM4x02
- HID Prox

Supported RFID cards 13.56 MHz:

- **ISO14443A** (MIFARE Classic, MIFARE Plus, MIFARE Mini, MIFARE Ultralight, MIFARE DESFire CSN only)
- **PicoPass** (HID iClass CSN, Picopass)
- **FeliCa** (Standard, Lite)
- **ST SR** (SR, SRI, SRIX)
- **My2N**
- **2N PICard**

## Product Description



### **Part No. 9161151**

Axis Part No. 02911-001

2N Access Unit M Bluetooth & RFID – 125 kHz, 13.56 MHz, NFC

Combining an access reader, a touch keypad and a controller, the device is used for access control inside and outside of buildings.

The device is used for reading RFID cards in the 125 kHz and 13.56 MHz bandwidths with the NFC support.

It is a 3m LAN cable version.

Supported RFID cards 125 kHz:

- EM4x02
- HID Prox

Supported RFID cards 13.56 MHz:

- **ISO14443A** (MIFARE Classic, MIFARE Plus, MIFARE Mini, MIFARE Ultralight, MIFARE DESFire CSN only)
  - **PicoPass** (HID iClass CSN, Picopass)
  - **FeliCa** (Standard, Lite)
  - **ST SR** (SR, SRI, SRIX)
  - **My2N**
  - **2N PICard**
-

## Product Description



### Part No. 9161161

Axis Part No. 02912-001

2N Access Unit M Touch keypad & RFID – 125 kHz, 13.56 MHz, NFC

Combining an access reader, a touch keypad and a controller, the device is used for access control inside and outside of buildings.

The device is used for reading RFID cards in the 125 kHz and 13.56 MHz bandwidths with the NFC support.

It is a 3m LAN cable version.

Supported RFID cards 125 kHz:

- EM4x02
- HID Prox

Supported RFID cards 13.56 MHz:

- **ISO14443A** (MIFARE Classic, MIFARE Plus, MIFARE Mini, MIFARE Ultralight, MIFARE DESFire CSN only)
- **PicoPass** (HID iClass CSN, Picopass)
- **FeliCa** (Standard, Lite)
- **ST SR** (SR, SRI, SRIX)
- **My2N**
- **2N PICard**

## Accessories

### Accessories for Installation

**2N Access Unit M** is designed for door frame mounting both outdoors and indoors.

Choose the proper accessories for your particular installation needs.



### Part No. 916121

Axis Part No. 02940-001

Flush mounting box

The flush mounting box is used for connection and storage of cables below the device.



### Part No. 916122

Axis Part No. 02932-001

Mounting backplate

The wall mounting backplate is used for connection and storage of cables below the device.

## Extenders



**Part No. 9159010**

Axis Part No. 01386-001

Security Relay

A handy add-on that significantly enhances security. It prevents lock tampering.

To be installed between the protected device from which it is also powered and the lock controlled by it.

---



**Part No. 9155198SET**

Axis Part No. 01975-001

Security Package for 2N Devices

The security package provides increased door security.

The safety package includes a safety relay, a protection switch and an I/O module.

## Power Supply



**Part No. 91378100E (with EU cable)**

**Part No. 91378100US (with US cable)**

Axis Part No. 01403-001

One-port PoE injector

For intercom supply via Ethernet cable where the PoE switch is absent.

---



**Part No. 91341481E (with EU cable)**

**Part No. 91341481US (with US cable)**

Axis Part No. 02520-001

Stabilized 12 V / 2 A power supply

The supply must be used where PoE is not used.

---

## Product Description



### **Part No. 932928**

Axis Part No. 02529-001

12 V transformer

For 230 V mains voltage.

Designed for external supply of electric locks.

## Other accessories



### **Part No. 9159013**

Axis Part No. 02523-001

Departure button

The departure button is connected to the device logic input for opening the door from inside the building.

---



### **Part No. 9159012**

Axis Part No. 01388-001

Magnetic door contact

Set for installation on a door, enabling the status of door opening to be ascertained. Used where the device is used for door protection, open door detection or forced opening.

---



### **Part No. 9134173**

Axis Part No. 01384-001

MIFARE RFID chip card, 13.56 Hz

RFID chip card, MIFARE Classic 1k, 13.56 MHz.

---



### **Part No. 9134174**

Axis Part No. 01385-001

MIFARE RFID chip fob, 13.56 MHz

RFID chip fob, MIFARE Classic 1k, 13.56 MHz.

---

## Product Description

### Part No. 9134165E

Axis Part No. 01395-001

EM RFID chip card, 125 Hz

RFID chip card, type EM4100, 125 kHz.



### Part No. 9134166E

Axis Part No. 01396-001

EM RFID chip fob, 125 kHz

RFID chip fob, type EM4100, 125 kHz.



### Part No. 11202601

Axis Part No. 02787-001

MIFARE DESFire RFID chip card, 13.56 MHz

RFID chip fob, type MIFARE DESFire EV3 4 K, 13.56 MHz (ISO/IEC14443A).

Suitable for data encryption in PICard Commander.

The package includes 10 pieces.

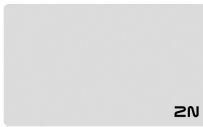

### Part No. 11202602

Axis Part No. 02788-001

MIFARE DESFire RFID fob, 13.56 MHz

RFID fob, type MIFARE DESFire EV3 4 K, 13.56 MHz (ISO/IEC14443A).

Suitable for data encryption in PICard Commander.

The package includes 10 pieces.



### Part No. 9137420E

Axis Part No. 01399-001

External RFID reader, 125 kHz

External RFID card reader connectable to a PC via a USB interface.

Suitable for system administration and adding of EM41xx cards (125 kHz) using the device web configuration or PICard Commander.



## Product Description



### Part No. 9137421E

Axis Part No. 01399-001

External RFID reader, 13.56 MHz + 125 kHz, NFC/HCE

External RFID card reader connectable to a PC via a USB interface.

Suitable for system administration and adding of 13.56 MHz/125 kHz cards and Android devices with NFC/HCE support using the device web configuration or the Access Commander.

Suitable for uploading of MIFARE DESFire cards into the PICard Commander encryption application.

The following RFID cards can be read:

Supported RFID cards 125 kHz:

- EM4x02
- HID Prox

Supported RFID cards 13.56 MHz:

- **ISO14443A** (MIFARE Classic, MIFARE Plus, MIFARE Mini, MIFARE Ultralight, MIFARE DESFire CSN only)
- **PicoPass** (HID iClass CSN, Picopass)
- **FeliCa** (Standard, Lite)
- **ST SR** (SR, SRI, SRIX)
- **My2N**
- **2N PICard**

The device can also read the 13.56 MHz 2N PICard RFID cards.

---

## Product Description



### Part No. 9137424E

Axis Part No. 01527-001

External secured RFID reader, 13.56 MHz + 125 kHz, NFC/HCE

External secured RFID card reader connectable to a PC via a USB interface.

Suitable for system administration and adding of 13.56 MHz/125 kHz cards and Android devices with NFC/HCE support using the device web configuration or the Access Commander.

Suitable for uploading of MIFARE DESFire cards into the PICard Commander encryption application.

The following RFID cards can be read:

Supported RFID cards 125 kHz:

- EM4x02
- HID Prox

Supported RFID cards 13.56 MHz:

- **ISO14443A** (MIFARE Classic, MIFARE Plus, MIFARE Mini, MIFARE Ultralight, MIFARE DESFire CSN only)
- **PicoPass** (HID iClass CSN, Picopass)
- **FeliCa** (Standard, Lite)
- **ST SR** (SR, SRI, SRIX)
- **My2N**
- **2N PICard**

---

### Part No. 9137410E



Axis Part No. 01397-001

External IP relay, 1 output

Stand-alone IP relay, which can be controlled from an intercom via HTTP commands and helps control devices from an unlimited distance.

---

### Part No. 9137411E



Axis Part No. 01398-001

External IP relay, 4 outputs, PoE

Stand-alone IP relay, which can be controlled from an intercom via HTTP commands and helps control devices from an unlimited distance.

---

## Product Description

### Part No. 9159014EU/US/UK



Axis Part No. 01404-001

2N 2Wire (set of 2 adaptors and power source for EU/US/UK)

The 2N 2Wire converter allows you to use the existing 2-wire cabling from your original doorbell or door intercom for connecting any IP device. You do not have to configure anything, all you need is one 2N 2Wire unit at each end of the cable and a power supply connected to at least one of these units. The 2N 2Wire unit then provides PoE power not only to the second converter, but to all of the connected IP end devices.

---

### Part No. 9160501

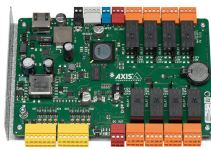

Axis Part No. 0820-001

AXIS A9188 Network I/O Relay Module

The relay is part of the lift access solution. One relay can control up to 8 floors. Intercom or access unit can be interconnected with up to 8 AXIS A9188 lift relays. The solution is thus suitable for up to 64 floors.

---

### Part No. 9154004



Axis Part No. 01479-001

Water-proof metal button

Suitable for internal RFID card reader.

## Package Completeness Check

Please check the product delivery before installation. Contents:

1x **2N Access Unit M**

---

1x Certificate of ownership

---

1x Quick Start manual

---

1x Metal wall holder (screwed to the device)

---

2x 8 x 40 mm dowel

---

## Product Description

2x 4.5 x 40 mm flat head screw with washer

---

1x M 3 x 8 mm stainless steel lens head screw for fitting device in holder (ISO 14583)

---

1x T10 and T20 dual Torx key

## Package Completeness Check for Installation Accessories

The flush mounting box package for **2N Access Unit M** includes:

### Part No. 916121

---

2x 3.5 x 8 mm thread-forming lens head screw for plastic with integrated backplate (WN 1411)

---

1x 3 x 16 mm thread-forming lens head screw for plastic (WN 1412)

The backplate package for **2N Access Unit M** includes:

### Part No. 916122

---

2x 3.5 x 8 mm thread-forming lens head screw for plastic with integrated backplate (WN 1411)

# Installation

## Mechanical Installation

### Installation Conditions

**Make sure that the following 2N Access Unit M installation conditions are met.**

- There must be enough space for the device installation.
- Make sure that the dowel holes have the required diameter. If the diameters are too large, the dowels may get loose! Use the mounting glue to secure the dowels if necessary.
- Do not use low-quality dowels to avoid their falling out of the wall!
- Make sure that the depths of the dowel holes are accurate!
- Before starting the mechanical installation on a selected place, make sure carefully that the preparations associated with it (drilling, wall cutting) cannot damage the electrical, gas, water and other existing wires and pipes.
- The device is designed for vertical wall mounting (perpendicular to the floor) in the height of up to 1350 mm above the floor. If necessary, operate the device in a position other than as aforementioned for a short time only, for quick testing purposes in a servicing center, for example.
- Make sure that the plasterboard interior does not show a pressure value significantly different from that of the room, e.g. that it is not connected with overpressure ventilation. If the difference is too great, separate the device in terms of pressure (using, e.g., a mounting box) and seal the cable passage.
- The device is not designed for environments with increased vibrations such as means of transport, machine rooms and so on.
- The device is not intended for dusty environments and places with unstable humidity and abrupt temperature changes.
- The device may not be exposed to aggressive gas, acid vapors, solvents, etc.
- The device is not intended for direct connection into the Internet/WAN. The device must be connected to the Internet/WAN via a separating active network element (switch/router).
- The device cannot be operated on places exposed to direct sunshine and near heat sources.
- Keep some free space above and below the device to allow air to flow and conduct heat away.
- Avoid strong electromagnetic radiation on the installation site.
- Make sure that the VoIP connection is configured properly according to the SIP and other VoIP recommendations.



**CAUTION**

- When the proper installation instructions are not met, water might get in and destroy the electronics. As the device circuits are constantly under voltage water leakage causes electrochemical reaction. The manufacturer's warranty shall be void for products damaged in this way!
- Exceeding the allowed operating temperature may not affect the device immediately but leads to premature ageing and lower reliability. For the acceptable range of operating temperatures and relative humidity values refer to [S. Technical Parameters](#).
- Any intentional mechanical damage to the device (drilling, main unit tampering, etc.) results in a loss of warranty.
- The device installation and setting should only be performed by professionally qualified persons.
- The installation and adjustment of this device, including any handling thereof, should only be carried out by persons qualified to do so.

**Surface Installation**

**2N Access Unit M** is designed for surface mounting in its basic package without accessories (wall, plaster-board, door frames).

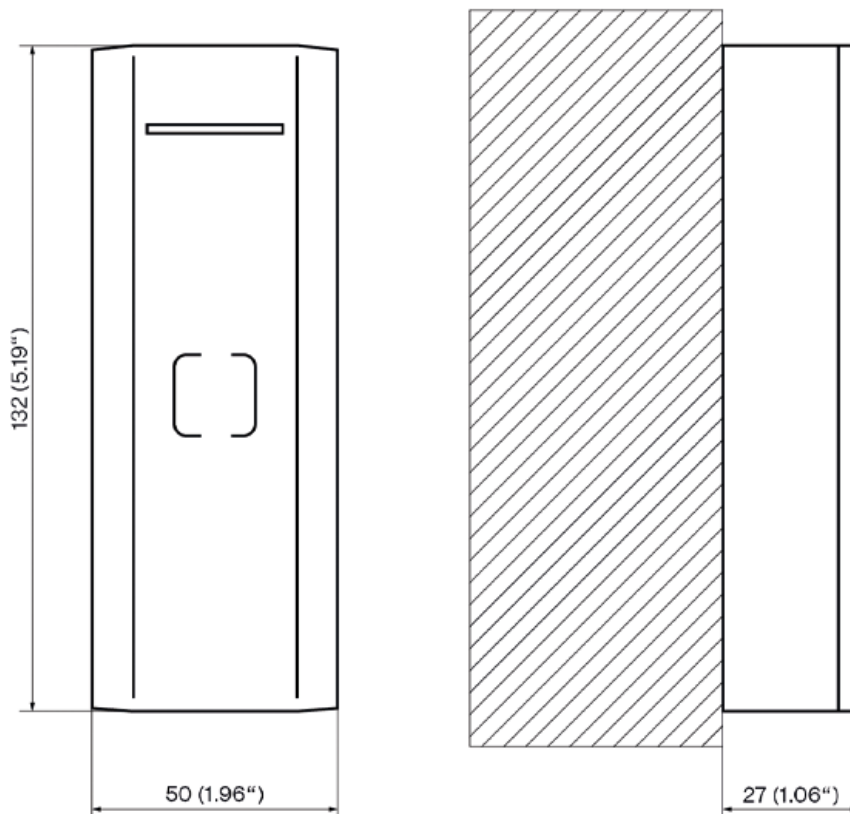

What you need for mounting:

- **2N Access Unit M**
- Metal wall holder (screwed to the device)



**TIP**

Download the [drilling template](#) from 2N.com.



**NOTE**

Shortening the LAN cable in units Part No. **9161121**, **9161141**, **9161151** and **9161161** shall not render the warranty null and void.

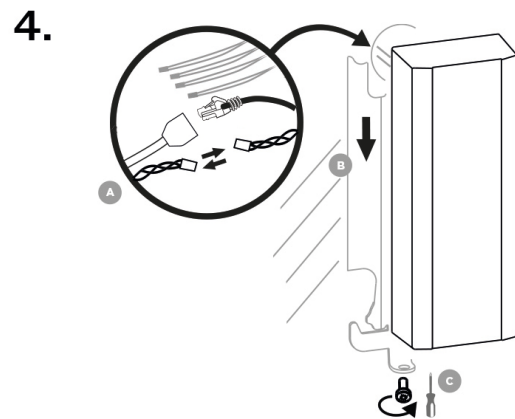
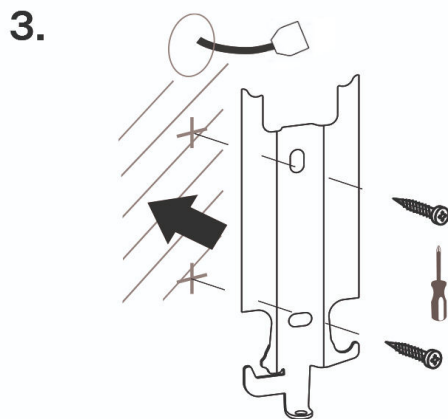
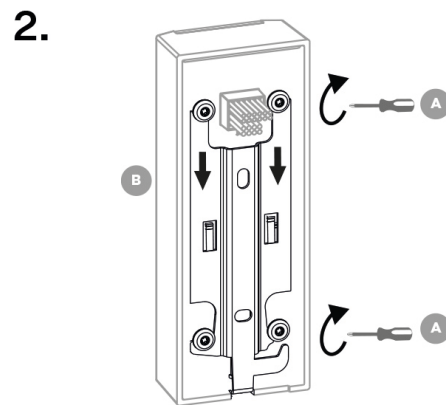
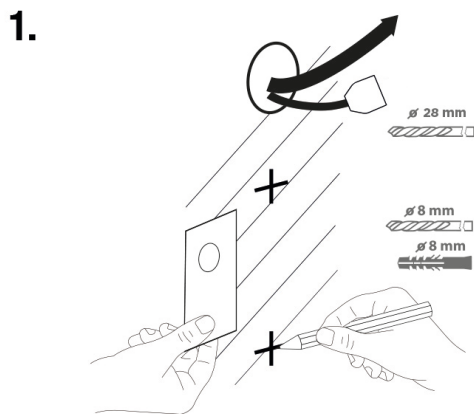

1. Use the drilling template shown on the device box to prepare holes of the required sizes for cabling and dowels on the selected place in the required height. Feed the cables out of the pre-drilled hole.
2. Pull the metal holder downwards to remove it from the device back side.



**WARNING**

Do not handle the screws on the device back side!

3. Then fit the holder through the dedicated holes using the screws enclosed.
4. Interconnect the accessible cables with the cabling **2N Access Unit M**. Put the device carefully on the installed holder from above downwards and fix its position on the holder carrying elements by tightening the screw from the bottom through the holder hole.

## Surface installation on mounting backplate

The mounting backplate is used for placing cables below the device **2N Access Unit M** during surface installation.



### NOTE

Shortening the LAN cable in units Part No. **9161121**, **9161141**, **9161151** and **9161161** shall not render the warranty null and void.

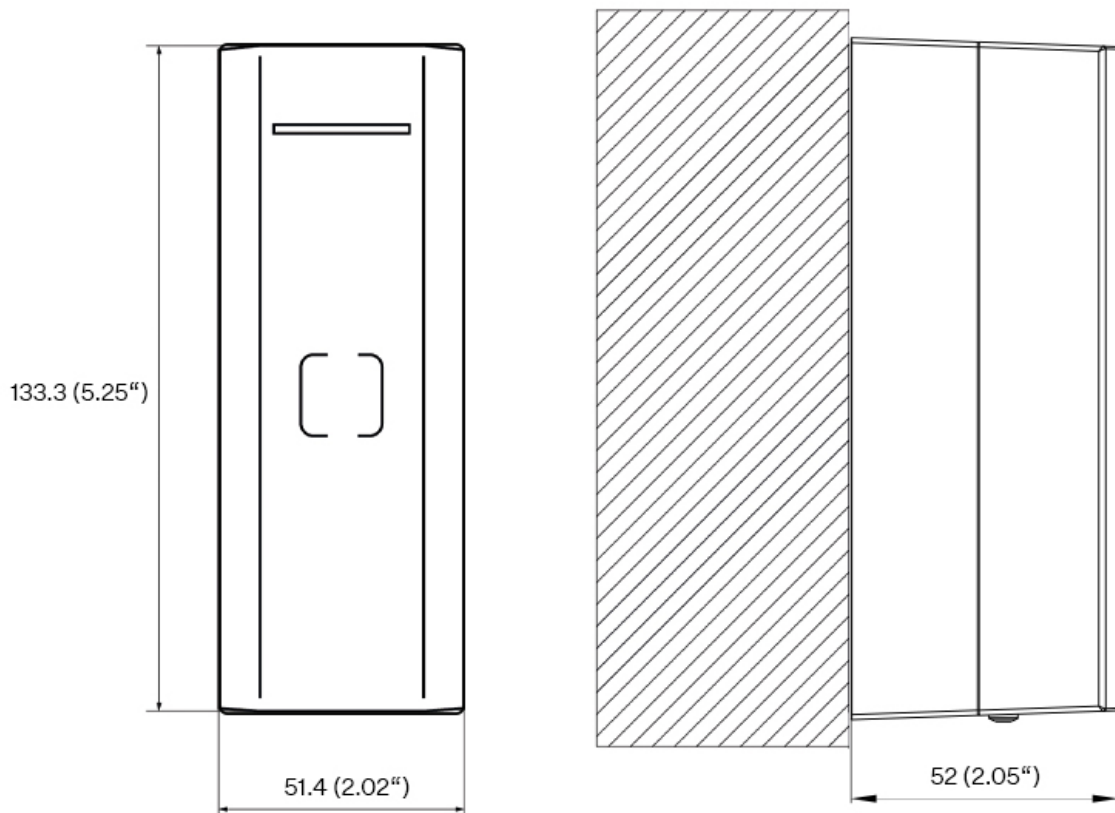

What you need for mounting:

- **2N Access Unit M**
- Mounting backplate (Part No. **916122**)
- Metal wall holder (screwed to the device)



### TIP

Download the [drilling template](#) from 2N.com.

## Installation

1.

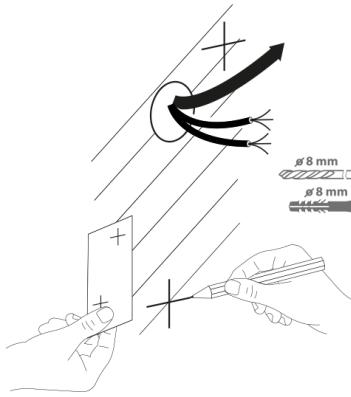

2.

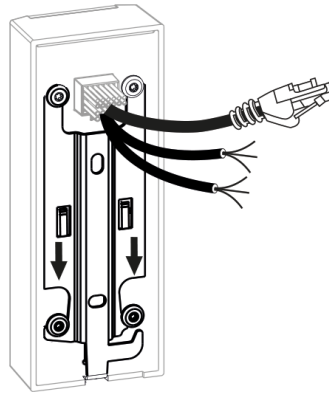

3.

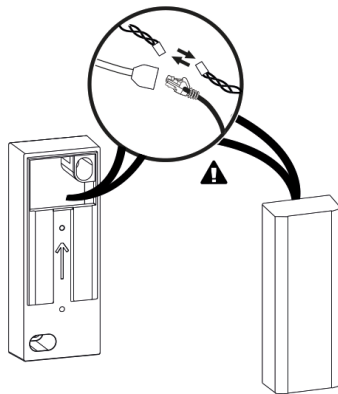

4.

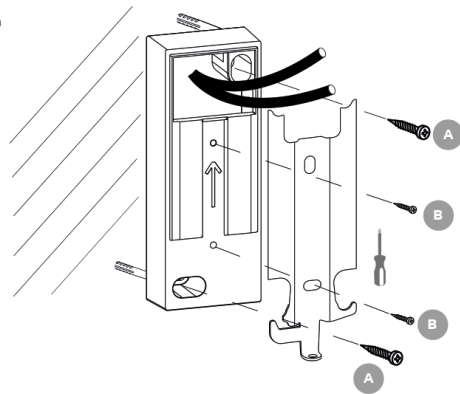

5.

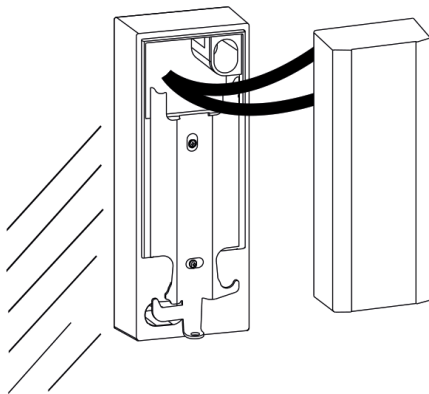

6.

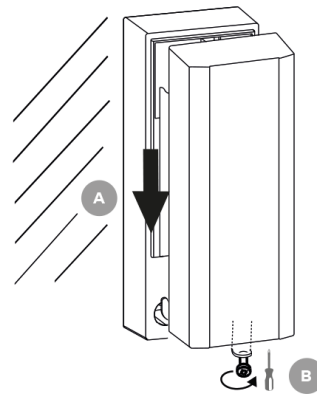

### WARNING

Do not handle the screws on the device back side!

1. Prepare dowel holes on a selected place and in a selected height using a drilling template shown on the package. Cut a cable installation hole in the backplate.
2. Pull the metal holder downwards on the device back side.

- Put the cables in the backplate and put the backplate against the wall. If you connect the device to installed cables, connect the wires.



**WARNING**

Insulate the wire joints with a shrink tube and glue to keep the cover rating as much as possible.

- Anchor the backplate to the base using screws and dowels. Screw the metal holder to the backplate.
- Put the device on the backplate and insert the remaining cables carefully in the backplate.
- Insert the device on the holder by pulling it from top to bottom making sure that the holder stops drive under the screw heads on the device back side. When the device touches the holder carrying elements, fix the device position by tightening the screw through the holder hole from the bottom.

**Flush mounting**

The flush mounting box allows you to place cables in the wall below **2N Access Unit M** and mount the device.



**NOTE**

Shortening the LAN cable in units Part No. **9161121**, **9161141**, **9161151** and **9161161** shall not render the warranty null and void.

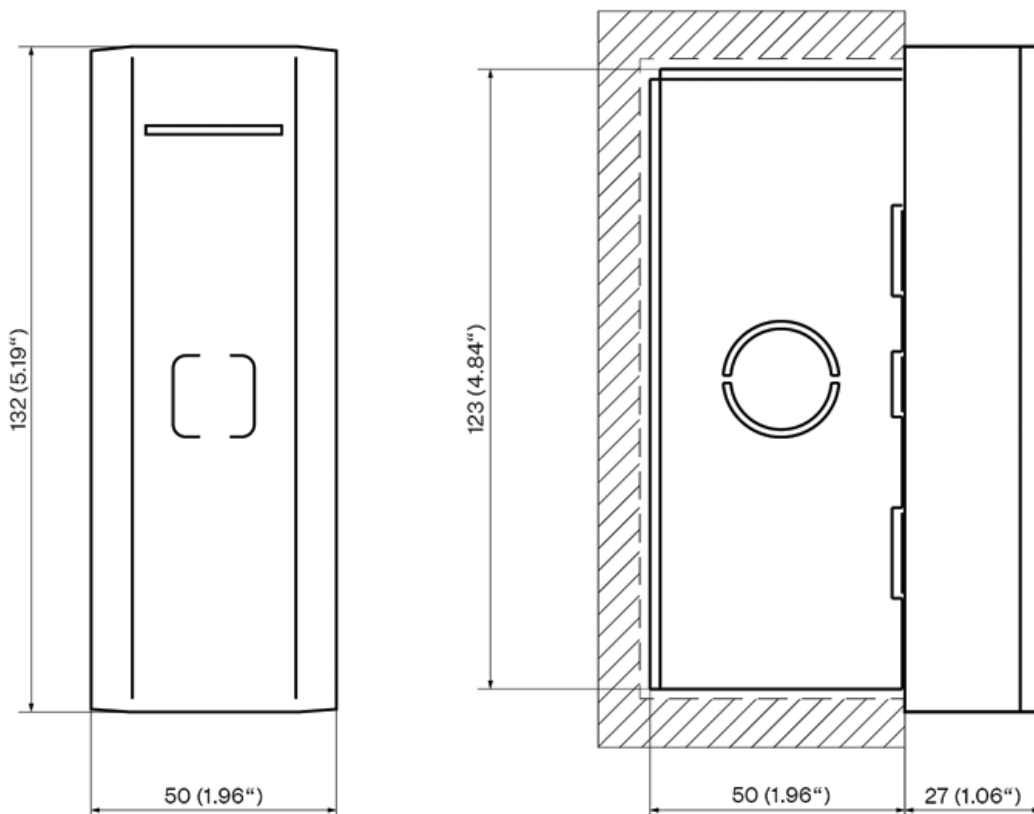

What you need for mounting:

- **2N Access Unit M**
- Flush mounting box (Part No. **916121**)
- Metal wall holder (screwed to the device)



**TIP**

Download the [drilling template](#) from 2N.com.

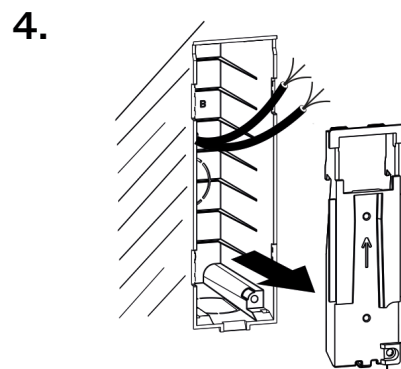
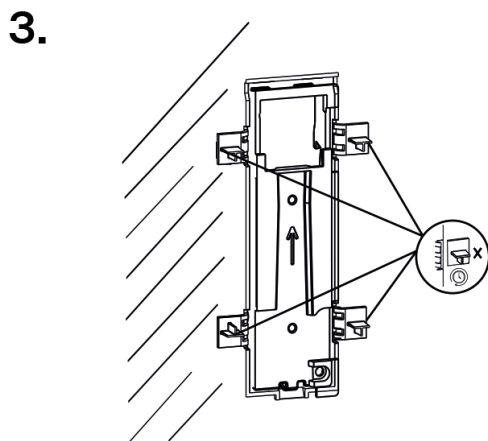
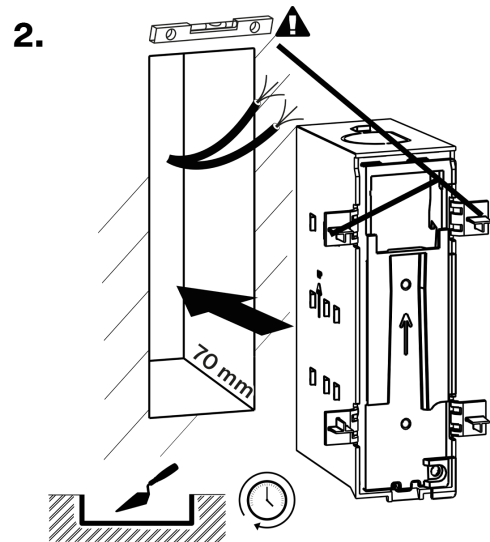
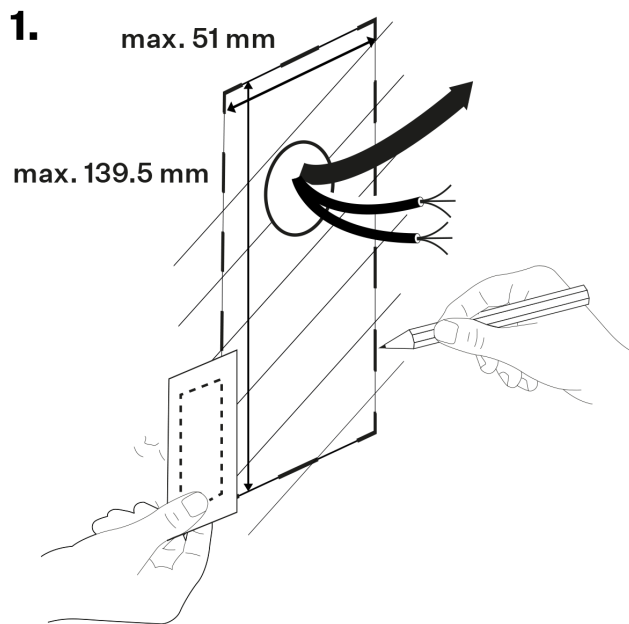

# Installation

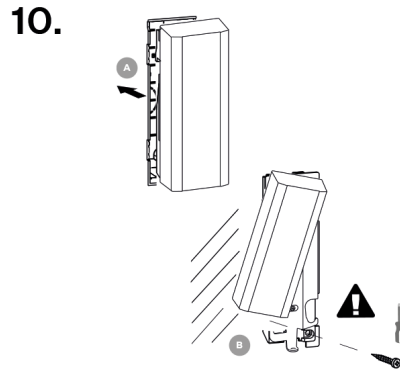
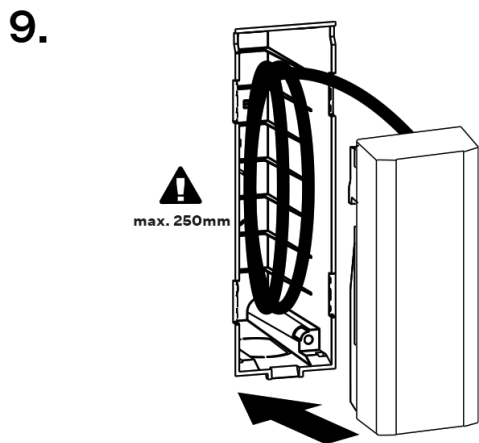
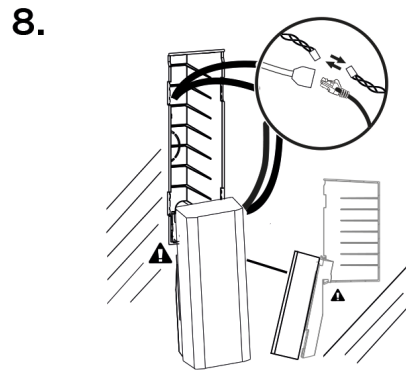
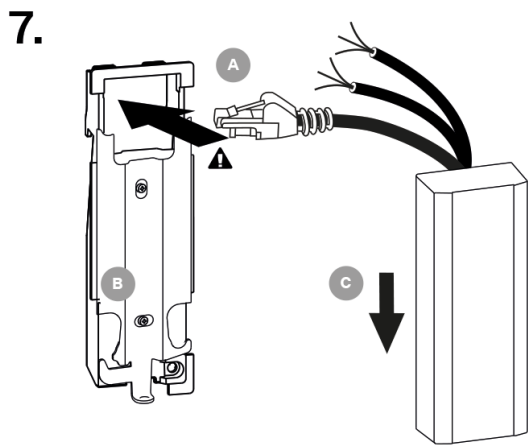
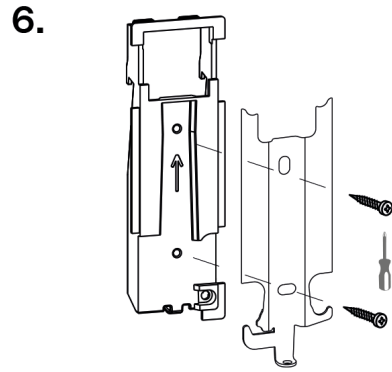
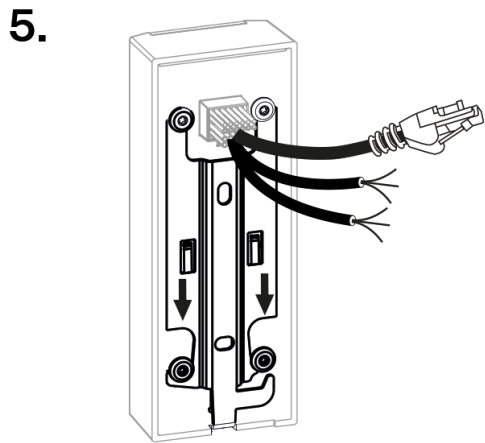

11.

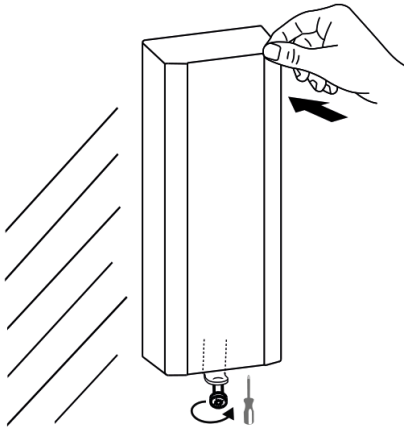

**WARNING**

Do not handle the screws on the device back side!

1. Make a hole of the size of 1300 (h) x 400 (w) x 650 (d) mm for the mounting box installation. Remove the box cover and the cable installation blank.
2. Replace the cover on the box to be used as a walling spacer. If the box location is convenient, wall the box in.
3. When the walling material has hardened, break off the side stops.



**WARNING**

Insulate the wire joints with a shrink tube and glue to keep the cover rating as much as possible!

4. Remove the cover from the box.
5. Pull the metal holder downwards on the device back side to remove it.
6. Fit the holder to the box cover using the included screws.
7. Pull the cables leading from the device through the cover hole. Press the holder screwed to the cover to the device and move it upwards carefully to make the holder stops drive under the screw heads on the device back side.
8. If you connect the device to accessible cables, hang the device on the cover with the cover hooks into the box bottom holes. Connect the wires.
9. Insert the wires in the box keeping in mind that the maximum cable length is 250 mm.
10. Insert the cover with the device in the box. Pull the device carefully upwards to release it from the holder. Turn the device bottom part by approx. 30° to the left along the wall without moving it away from the wall. Tighten the screw into the hole on the right-hand bottom part of the box to anchor the box cover.
11. Replace the device into the vertical position and put on the holder. When the device touches the holder carrying elements, fix the device position by tightening the screw through the holder hole from the bottom. Push the device upper part to fix the device in the final position.

## Electric Installation

### Power Supply

**2N Access Unit M** can be fed either directly from the LAN if equipped with PoE 802.3af (Class 0, max. 12,95 W) supporting network elements or from an external 12 V ± 1 V / 1 A DC power supply.



**CAUTION**

- The external power supply should comply with PS2/LPS.



**WARNING**

**2N Access Unit M** cannot be fed from an external power supply and PoE at the same time. A combined supply might result in a device damage.

**PoE Supply**

**2N Access Unit M** is compatible with the PoE 802.3af (Class 0, max. 12,95 W) technology (Class 0, max. 12.95 W) and can be supplied directly from the LAN via compatible network elements. If your LAN does not support this technology, insert a PoE injector, between **2N Access Unit M** and the nearest network element. This power supply provides **2N Access Unit M** with 12 W for its own feeding .

**External Power Supply**

Use a SELV supply 12 V ± 1 V dimensioned to the current consumption according to the required power output for the to make your device work reliably.



**CAUTION**

Make sure that the wires are firmly attached to the terminal to avoid any free contact.

**Adapter Connection (1341481, 02520-001)**

The white wire at the end of the adapter carries the positive charge (+), the black wire carries the negative charge (-).

**Combined Power Supply**

**Power Consumption for Device Versions**

State	Part Nos. 916112/9161121  Axis Part No. 02393-001/02909-001	Part Nos. 916114/9161141  Axis Part No. 02394-001/02910-001	Part Nos. 916115/9161151  Axis Part No. 02395-001/02911-001	Part Nos. 916116/9161161  Axis Part No. 02396-001/02912-001
At re- lax	1.6 W	1.5 W	1.5 W	1.5 W

Installation

<b>State</b>	<b>Part Nos. 916112/9161121</b>	<b>Part Nos. 916114/9161141</b>	<b>Part Nos. 916115/9161151</b>	<b>Part Nos. 916116/9161161</b>
	<b>Axis Part No. 02393-001/02909-001</b>	<b>Axis Part No. 02394-001/02910-001</b>	<b>Axis Part No. 02395-001/02911-001</b>	<b>Axis Part No. 02396-001/02912-001</b>
LED – white strip 100 %	0.12 W	0.12 W	0.12 W	0.12 W
LED – green strip 100 %	0.15 W	0.15 W	0.15 W	0.15 W
LED – red strip 100 %	0.20 W	0.20 W	0.20 W	0.20 W
LED – Blue- tooth 100 %	–	–	0.06 W	–
LED – key- pad back- light 100 %	–	–	–	0.15 W
Relay at stand- ard room tem- pera- ture mode	0.14 W	0.14 W	0.14 W	0.14 W

## Installation

State	Part Nos. 916112/9161121	Part Nos. 916114/9161141	Part Nos. 916115/9161151	Part Nos. 916116/9161161
	Axis Part No. 02393-001/02909-001	Axis Part No. 02394-001/02910-001	Axis Part No. 02395-001/02911-001	Axis Part No. 02396-001/02912-001
OUT1 at maxi- mum possi- ble load	6 W	6 W	6 W	6 W
Audio	0.7 W	0.7 W	0.7 W	0.7 W

### Cabling Description

#### Cable connection for Part Nos. 9161121, 9161141, 9161151, 9161161

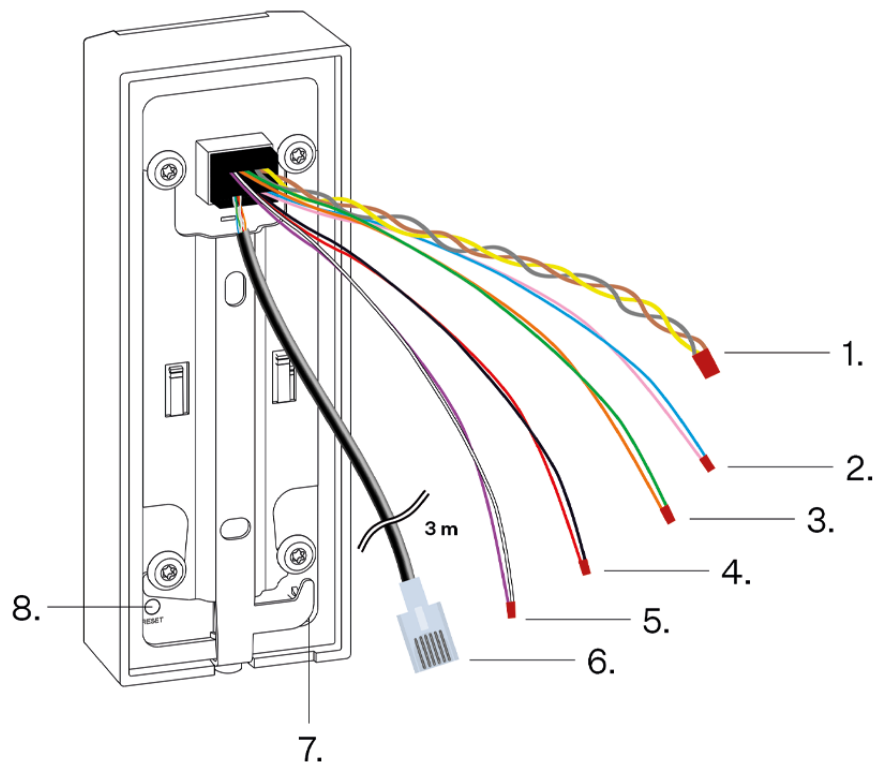

The LAN cable is 3 m long and RJ-45 male terminated. All the other available cables are 35 cm long.

Legend to figure	Component	Color Coding	Description
1	RELAY	yellow NO, brown NC, gray COM	Relay cable with a 30 V / 1 A AC/DC NO/NC contact. Used for connection of non-critical devices only (lights, e.g.).
2/3	Input 1/2	pink "+", blue "-"  / orange "+", green "-"	The terminals are used as inputs in the passive/active mode (-30 V to +30 V DC) for departure button, open door sensor, ESS etc. connection  <ul style="list-style-type: none"> <li>• OFF = open contact OR <math>U_{IN} &gt; 1.5 \text{ V}</math></li> <li>• ON = closed contact OR <math>U_{IN} &lt; 1.5 \text{ V}</math></li> </ul>
4	Ext. Power	red "+", black "-"	For external power supply connection (12 V / 1 A).
5	Active output	white "+", violet "-"	An active output cable for the connection of <b>the Security Relay</b> or an electric lock: 8 to 12 V DC according to power supply (PoE: 10 V; adapter: power supply voltage minus 2 V), up to 600 mA.
6	LAN cable	-	For LAN connection (PoE 802.3af (Class 0, max. 12.95 W)).
7	Tamper Switch	-	A switch that helps detect the removal of a device from the holder installed.
8	RESET	-	RESET / FACTORY RESET button.



**WARNING**

The 12V output is used for lock connection. If the device is installed in a location where there is a danger of unauthorized access (building front, e.g.), we strongly recommend the use of the 2N Security Relay (9159010, 01386-001) to ensure the maximum installation security.

**WARNING**

If a coil containing device is connected, e.g. relays/electromagnetic locks, it is necessary to protect the device output against voltage peak while switching off the induction load. For this way of protection we recommend a 1 A / 1000 V diode (e.g., 1N4007, 1N5407, 1N5408) connected antiparallel to the device.

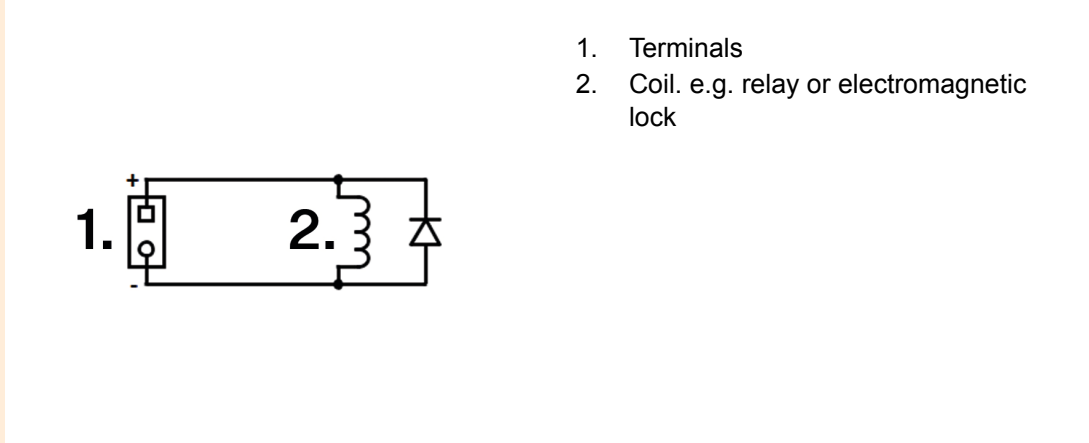

1. Terminals
2. Coil. e.g. relay or electromagnetic lock

**Cable Connection**

The **2N Access Unit M** signals are led out by insulated wires stripped 1 cm at the ends (this does not apply to the Ethernet cable with a connector). Choose any of the below mentioned methods to connect the wires:

- by twisted pair,
- using a terminal board,
- by soldering,
- screw connection,
- using WAGO terminals,
- crimping using sockets.

**LAN Connection**

**2N Access Unit M** is connected to the LAN by inserting a SFTP cable ( Cat-5e or higher) terminated with an RJ-45 plug into the marked LAN connector on the device . As the device is equipped with the Auto-MDIX function, you can use either the straight or crossed cable version.

This device must be deployed within a network infrastructure that provides adequate protection against Denial-of-Service (DoS) attacks and similar network-based threats. The device does not include built-in protection against high-volume or malicious traffic and relies on the surrounding network environment—such as firewalls, intrusion prevention systems, or rate limiting—for defense. Failure to implement appropriate network security measures may lead to service degradation or unavailability. The equipment's user documentation shall contain a [description of all exposed network interfaces and all services exposed via network interfaces](#), which are delivered as part of the factory default state.

**CAUTION**

- We recommend the use of a LAN [surge protection](#) (p. 30).
- We recommend the use of a shielded SFTP Ethernet cable.

## Overvoltage Protection

The 2N device cables have to be protected against atmospheric overvoltage caused by external causes (lightning, e.g.). A surge can damage a device installed outside/inside the building if the wires are unprotected.

Therefore, we recommend that additional overvoltage protectors (OVP) be installed on the outer walls or roof for all the wires leading outside the building. Keep the following instructions while installing overvoltage protectors:

- Make sure that the overvoltage protector is installed as close as possible to the device installed outside the building.
- Make sure that the overvoltage protector is installed as close as possible to the device installed on an external part of the building.
- Make sure that the overvoltage protector is installed as close as possible to the point where the cabling leaves the building.

## Examples of Overvoltage Protection Installation

**Overvoltage protection installation diagram for a device installed on the building facade and cables outside the building**

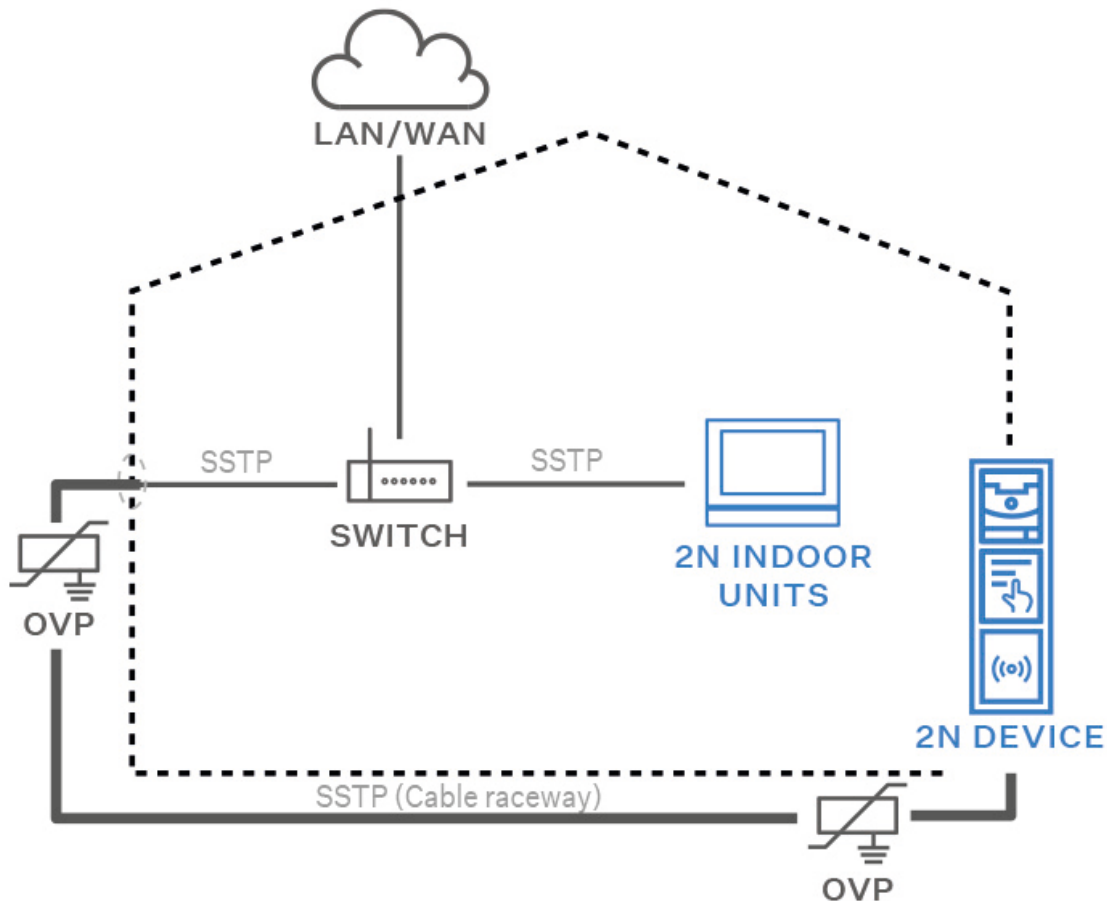

**Overvoltage protection installation diagram for a device installed on the building facade and cables inside the building**

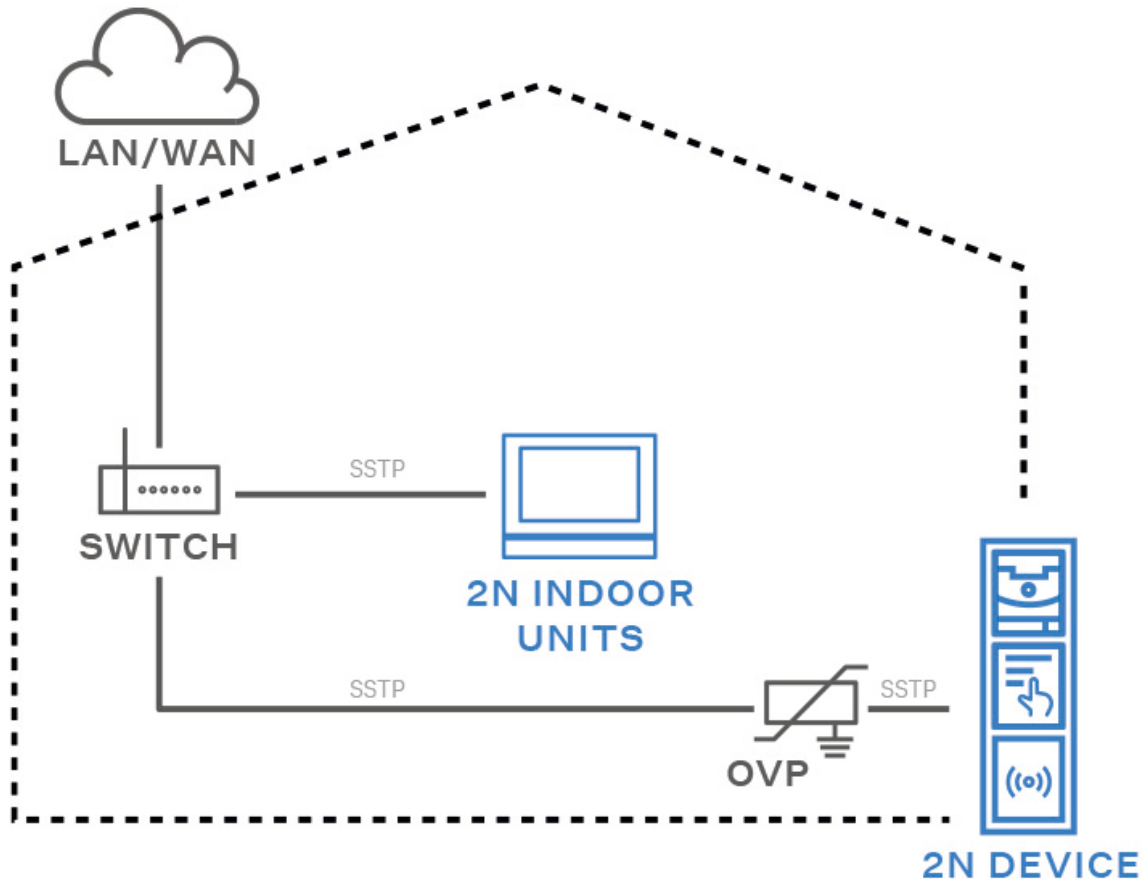

**Overvoltage protection installation diagram for a device and cables installed outside the building**

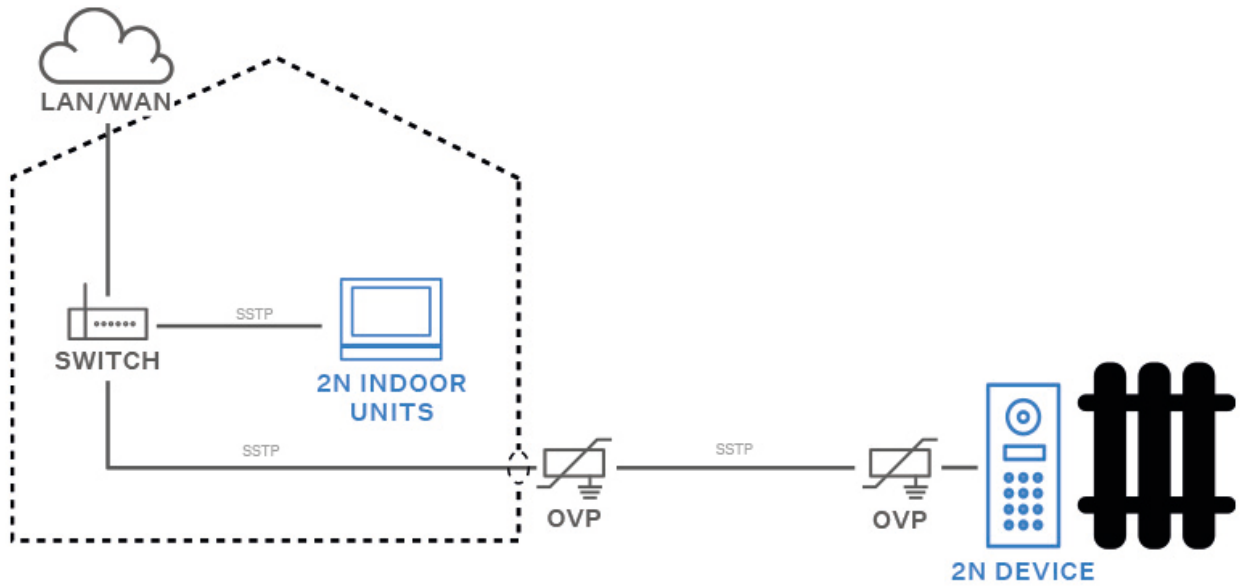

# Brief Guidelines

## IP Address Retrieval

To retrieve the device IP address, take the following steps:

- Use the freely accessible 2N IP Utility.
- Use hardware (RESET button).

### IP Address Retrieval Using 2N IP Utility

The 2N IP Utility application helps find the 2N device IP address in the LAN. Download 2N IP Utility from the [2N.com](https://www.2n.com) website. Make sure that Microsoft .NET Framework 4.7.2 is installed for successful app installation.

1. Run the 2N IP Utility installer.
2. The Installation Wizard will help you with the installation.
3. Having installed 2N IP Utility, start the application using the Microsoft Windows Start menu. Once started, the application begins to automatically search the LAN for all the 2N and AXIS devices which have been DHCP/statically assigned IP addresses. These devices are then shown in a table.

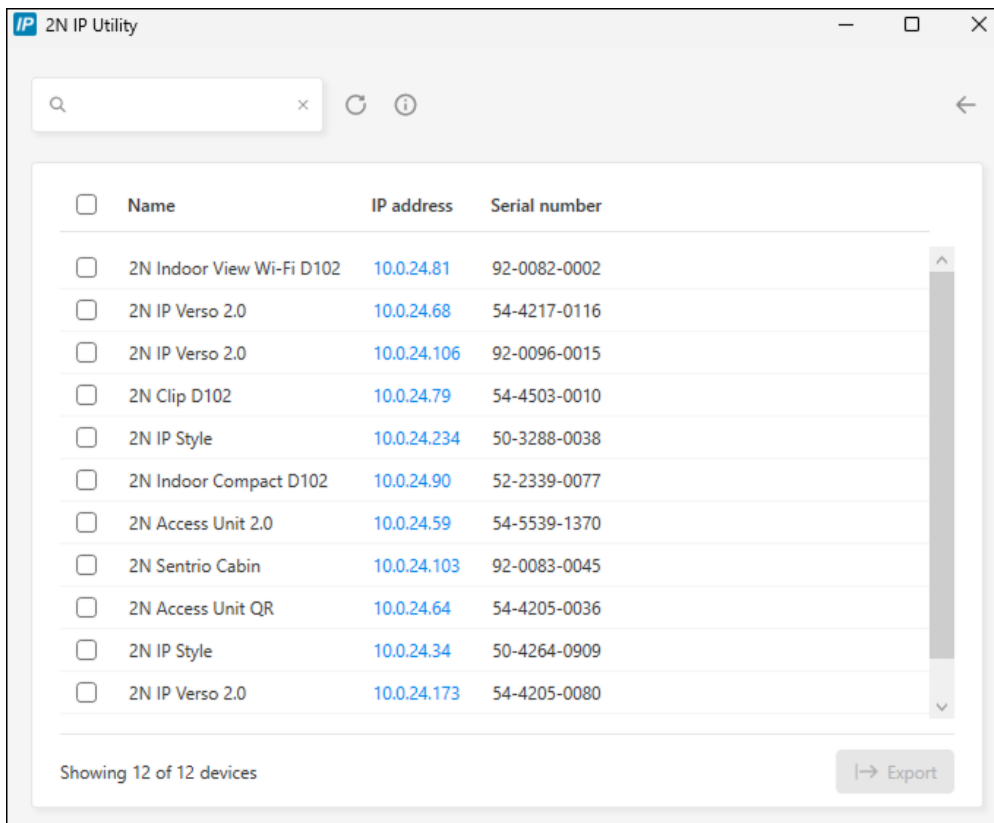

4. Select the device to be configured and left-click it. This opens the right-hand part of the web configuration interface window.



**TIP**

- Access to the web configuration interface is also possible via the **Open in external browser** button, which opens the interface in a separate browser window.
- Click a device in the list to display detailed information. Click the **IP settings** button to change the IP address by entering the required static IP address or activating DHCP.
- The application also allows you to export selected devices into a CSV file. First select a device by ticking the boxes in the list, then use the **Export** button that appears at the bottom of the window. The exported file shall include the names, IP addresses and serial numbers of the selected devices.

The default login data are:

Username: **Admin**

Password: **2n**

It is necessary to change the password immediately upon the first login.



**TIP**

It is recommended that a password is used that is difficult to break. It is not recommended that names, places or things, especially those closely related to the user, are used in the password.

For increased password security, it is recommended that:

- the random password generator is used,
- the password length is 12 characters at least,
- various characters from different character sets are combined (small/capital letters, digits, special characters, etc.).

## IP Address Retrieval Using the RESET button

Follow the instructions below to retrieve the current IP address:

1. Press the button RESET and keep it pressed.
  - a. Wait until the red and green LEDs go on simultaneously on the device and the acoustic signal can be heard 🗣️ (approx. 15–35 s).
2. Release the RESET button.
3. The device announces the current IP address via the speaker automatically.

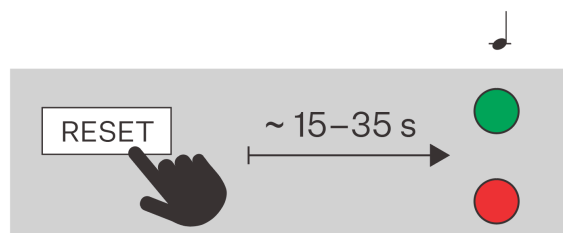

**NOTE**

The delay after pressing RESET till the first light and sound signaling is set to 15–35 s depending on the device model used.

## Access to web device configuration

Configure **2N Access Unit M** via a web configuration interface, which is accessible from a web browser.



You need to know the IP address or domain name of the device for access to the interface. Make sure that the device is connected to the local IP network and powered.

The web configuration interface can also be accessed from the connected My2N portal or the 2N Access Commander configuration tool.

### Web Configuration Interface Login

1. Start your Internet browser.
2. Enter the device IP address or domain name (refer to Subs.[Finding devices in the network](#)).
3. If no certificate has been generated for the IP address, a security certificate invalidity notification may appear. In that case, confirm that you want to go to the web configuration interface.
4. The login screen is now displayed.
5. Enter the login data.  
The default login data are:
  - Username: **Admin**
  - Password: **2n**
6. After the first login, change the password.

### Access from 2N Access Commander

1. Log in to the Access Commander interface.
2. Go to the  Devices page.
3. For the selected device, press .

### Password Change

You must change the default password to get full access to the web configuration interface features. You cannot configure the device without changing the default password.

**TIP**

It is recommended that a password is used that is difficult to break. It is not recommended that names, places or things, especially those closely related to the user, are used in the password.

For increased password security, it is recommended that:

- the random password generator is used,
- the password length is 12 characters at least,
- various characters from different character sets are combined (small/capital letters, digits, special characters, etc.).

## Recommended browsers

The web configuration interface is optimized for the Chromium-based web browsers (Google Chrome, Microsoft Edge or Opera, e.g.). With other browsers, there may be slight differences in the interface function and appearance.

## Firmware Update

New firmware versions are available on the update server. If the web configuration interface does not provide access to the public Internet, it is possible to upload the firmware file manually to the device.



### NOTE

Firmware updates are not automatic. To ensure system integrity and eliminate unintentional failures, all updates must be manually confirmed or initiated by the user. Please check the release notes of the new version and verify compatibility with your existing infrastructure before performing any updates.

## Getting Firmware from Update Server



### CAUTION

In version 3.0.0, firmware updates from the update server are only available from the older version of the web interface.

- a. Click **Go to the old interface** in the web configuration interface header.

1. Go to **System > Maintenance > Firmware**.
2. Click **Check for Updates**.
3. If an update is available, its release notes are loaded. To start the upgrade, click **Upgrade** in the window header.
4. Once the firmware is uploaded successfully, the device is restarted automatically. After the restart, the device becomes fully operational with a new firmware version. The FW upgrade does not affect configuration.

## Uploading New Firmware from Storage

1. Go to **System > Maintenance > Firmware**.
2. Click **Upload Firmware**.
3. In the open dialog box, select a file from your own storage.
4. Click **Upload** to confirm the file upload.  
The device checks the firmware file and prevents you from uploading an incorrect or corrupt file.
5. Once the firmware is uploaded successfully, the device is restarted automatically. After the restart, the device becomes fully operational with a new firmware version. The FW upgrade does not affect configuration.

## Device Restart

To restart the device choose one of the following options:

- using the RESET button,

- via the web configuration interface.



**NOTE**

The device restart does not result in any change in the configuration settings.

**Restart Using RESET Button**

Press the button shortly (< 1 s) to restart the system without changing configuration.

**Restart Using Web Configuration Interface**

1. Open the web configuration interface.
2. Go to **System > Maintenance**.
3. Press **Restart Device** in the page header.

**Factory Default Reset**

Reset the device factory default values via software in System > Maintenance > Default reset.

Follow the instructions below **2N Access Unit M** to reset the factory default values via hardware:

**Factory Default Reset with RESET Button**

1. Press the button RESET and keep it pressed.
  - a. Wait until the red and green LEDs go on simultaneously on the device and the acoustic signal can be heard 🎵 (approx. 15–35 s).
  - b. Wait until the red LED goes off and an acoustic signal can be heard 🎵 (approx. for another 3 s).
  - c. Wait until the green LED goes off and the red LED goes on again and an acoustic signal can be heard 🎵🎵 (approx. for another 3 s).
  - d. Wait until the red LED goes off and the acoustic signal can be heard 🎵🎵🎵 (approx. for another 3 s).
2. Release the RESET button.

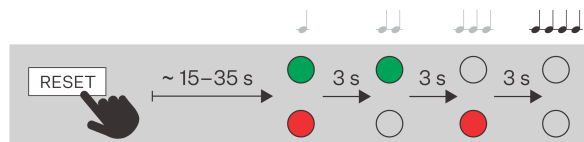

**CAUTION**

In case the factory default values are reset on the device with a firmware version 2.18 or higher, it is necessary to reprogram the 2N Security Relay using the instructions given in [Security Relay](#).

## Configuration via Hardware

Where software configuration is unavailable, the basic settings can be made using the RESET button (for location see Subs. ).

The RESET button helps you reset the factory default values, restart the device, retrieve the device IP address and switch the IP address static/dynamic mode.

### Device Restart

Press the button shortly (< 1 s) to restart the system without changing configuration.

### IP Address Retrieval Using the RESET button

Follow the instructions below to retrieve the current IP address:

1. Press the button RESET and keep it pressed.
  - a. Wait until the red and green LEDs go on simultaneously on the device and the acoustic signal can be heard 🎵 (approx. 15–35 s).
2. Release the RESET button.
3. The device announces the current IP address via the speaker automatically.



#### NOTE

The delay after pressing RESET till the first light and sound signaling is set to 15–35 s depending on the device model used.

### Static IP Address Setting with RESET Button

Follow the instructions below to switch on the Static IP address mode (DHCP OFF):

1. Press the button RESET and keep it pressed.
  - a. Wait until the red and green LEDs go on simultaneously on the device and the acoustic signal can be heard 🎵 (approx. 15–35 s).
  - b. Wait until the red LED goes off and an acoustic signal can be heard 🎵🎵 (approx. for another 3 s).

2. Release the RESET button.

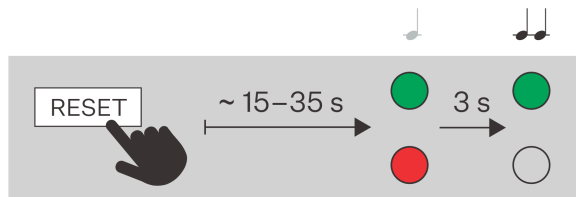

**NOTE**

The following network parameters will be set after restart:

- IP address: 192.168.1.100
- Network mask: 255.255.255.0
- Default gateway: 192.168.1.1

**Dynamic IP Address Setting via RESET**

Follow the instructions below to switch on the Static IP address mode (DCHP ON):



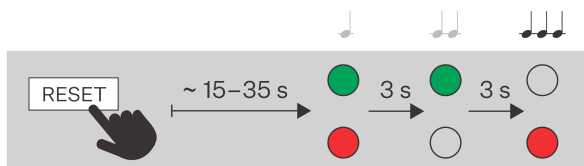

1. Press the button RESET and keep it pressed.
  - a. Wait until the red and green LEDs go on simultaneously on the device and the acoustic signal can be heard (approx. 15–35 s).
  - b. Wait until the red LED goes off and an acoustic signal can be heard (approx. for another 3 s).
  - c. Wait until the green LED goes off and the red LED goes on again and an acoustic signal can be heard (approx. for another 3 s).
2. Release the RESET button.



**NOTE**

The default network parameters will be set after restart.

## Factory Default Reset with RESET Button

1. Press the button RESET and keep it pressed.
  - a. Wait until the red and green LEDs go on simultaneously on the device and the acoustic signal can be heard  (approx. 15–35 s).
  - b. Wait until the red LED goes off and an acoustic signal can be heard  (approx. for another 3 s).
  - c. Wait until the green LED goes off and the red LED goes on again and an acoustic signal can be heard  (approx. for another 3 s).
  - d. Wait until the red LED goes off and the acoustic signal can be heard  (approx. for another 3 s).
2. Release the RESET button.

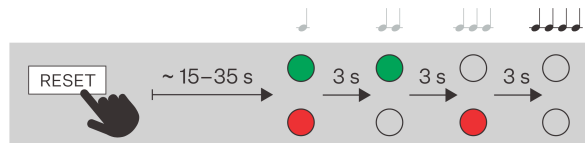

## Device Control



**2N Access Unit M** is a single-module access system available in several versions. All the versions include an integrated card reader module, which helps control access using an RFID card. With additional software settings, functions other than the door lock switch can be RFID card controlled too.

The device control depends on the product version:

- using RFID cards and chips – by tapping a card/chip on the device,
- using the **2N My2N** application – by pressing the device touchscreen in the vicinity of a mobile device with **2N My2N** logged in,
- using NFC,
- by entering a numeric access code via a keypad application

### Signaling of Operational Statuses

The **2N Access Unit M** operational statuses are indicated by a light on the device front side. The light signal can be accompanied with an acoustic signal if set so. Refer to the 2N Access Unit Configuration Manual for .

Operational Status Visual Indication	Operational Status Description
	<p>The white LED light indicates the power supply and operation states.</p>
	<p>The green LED light goes on whenever a valid PIN code is entered via the keypad or a valid RFID card is applied. Subsequently, the set switch is activated.</p> <p>A valid authentication is indicated by an acoustic signal if set so.</p>
	<p>The red LED light goes on whenever an invalid PIN code is entered via the keypad or an invalid RFID card is applied. Subsequently, the set switch is not activated.</p> <p>An invalid authentication is indicated by an acoustic signal if set so.</p>



#### TIP

Adjust the LED backlight level in **Customization > Backlight** in the web configuration.

## Maintenance - Cleaning

**2N Access Unit M** contains no environmentally harmful components. Dispose of the device in accordance with the applicable legal regulations.

If used frequently, the device surface gets dirty. Use a piece of soft cloth moistened with clean water to clean the device. Use appropriate cleaning agents suitable for glasses, optical devices, screens, etc. We recommend that IT cleaning wipes are used.



### CAUTION

Use the product for the purposes it was designed and manufactured for, in compliance herewith. The manufacturer reserves the right to modify the product in order to improve its qualities.

If used frequently, the device surface gets dirty. Use a piece of soft cloth moistened with clean water to clean the device. Use appropriate cleaning agents suitable for glasses, optical devices, screens, etc. We recommend that IT cleaning wipes are used.

- Alcohol-based cleaners may not be applied.
- Do not use aggressive detergents (such as abrasives or strong disinfectants).
- Prevent water from getting inside the device.
- Clean the device in dry weather in order to make waste water evaporate quickly.



### TIP

To disinfect the surface of the device against bacteria and viruses (Anti-Covid) and maintain the hygienic conditions of critical surfaces and touch points, we recommend that you use the Zoono – Microbe Shield Surface Sanitiser spray.

# Troubleshooting

Refer to <https://www.2n.com/faqs> for the most frequently solved problems.

## Technical Parameters

### Power supply types

PoE IEEE PoE 802.3af (Class 0, max. 12,95 W) (Class 0, max. 12.95 W)

External supply 12 V  $\pm$  1 V / 1 A DC



#### WARNING

**2N Access Unit M** cannot be fed from an external power supply and PoE at the same time. A combined supply might result in a device damage.

### Audio

Speaker 1 W / 8  $\Omega$

### Interface

LAN 10/100BASE-TX with Auto-MDIX, RJ-45 female (pigtail)

Recommended cabling Cat-5e or higher

Supported protocols DHCP opt. 66, SMTP, 802.1x, TFTP, HTTP, HTTPS, Syslog

Passive switch (relay) NO/NC contact, up to 30 V / 1 A AC/DC

Active switch output 9.8 to 13.8 V DC according to power supply, up to 600 mA

- PoE: 11.6 V
- adapter: source voltage  $-0.4$  V

**Tamper Switch**  
(part of the 2N Access Unit M main unit)

Inputs	Can be used in passive or active mode (-30 V to +30 V DC) <ul style="list-style-type: none"> <li>• OFF = open or <math>U_{IN} &gt; 1.5 \text{ V}</math></li> <li>• ON = short-circuited or <math>U_{IN} &lt; 1.5 \text{ V}</math></li> </ul>
--------	--

**Bluetooth**

Bluetooth	in compliance with BLE (Bluetooth Low Energy)
RX sensitivity	up to -98.9 dBm per 1 Mbps
Support of mobile applications	Android 10.0 and higher, iOS 17.0 and higher

**Mechanical Parameters**

Cover	Robust ASA/PC construction material, which is also used for such car parts as lateral mirrors, radiator masks, etc. + chemically hardened 3 mm thick glass
Weight	460 g
Operating temperature	-40 °C to 60 °C
Relative humidity	10 to 95 % (non-condensing)
Storing temperature	-40 °C to 70 °C
Recommended altitude	up to 2000 m
Protection class	IP55

## Technical Parameters

### Mechanical Parameters

---

Resistance level

IK07

## General Instructions and Cautions

Please read this User Manual carefully before using the product and follow the instructions and recommendations included therein.

Any use of the product that is in contradiction with the instructions provided herein may result in malfunction, damage or destruction of the product.

The manufacturer shall not be liable and responsible for any damage incurred as a result of a use of the product other than that included herein, namely undue application and disobedience of the recommendations and warnings.

Any use or connection of the product other than those included herein shall be considered undue and the manufacturer shall not be liable for any consequences arisen as a result of such misconduct.

Moreover, the manufacturer shall not be liable for any damage or destruction of the product incurred as a result of misplacement, incompetent installation and/or undue operation and use of the product in contradiction herewith.

The manufacturer assumes no responsibility for any malfunction, damage or destruction of the product caused by incompetent replacement of parts or due to the use of reproduction parts or components.

The manufacturer shall not be liable and responsible for any loss or damage incurred as a result of a natural disaster or any other unfavorable natural condition.

The manufacturer shall not be held liable for any damage of the product arising during the shipping thereof.

The manufacturer shall not make any warrant with regard to data loss or damage.

The manufacturer shall not be liable and responsible for any direct or indirect damage incurred as a result of a use of the product in contradiction herewith or a failure of the product due to a use in contradiction herewith.

All applicable legal regulations concerning the product installation and use as well as provisions of technical standards on electric installations have to be obeyed. The manufacturer shall not be liable and responsible for damage or destruction of the product or damage incurred by the consumer in case the product is used and handled contrary to the said regulations and provisions.

The consumer shall, at its own expense, procure software protection of the product. The manufacturer shall not be held liable for any damage incurred as a result of the use of deficient security software.

The consumer shall, without delay, change the access password for the product after installation. The manufacturer shall not be held liable or responsible for any damage incurred in connection with the use of the original password.

The manufacturer also assumes no responsibility for additional costs incurred by the consumer as a result of making calls to increased tariff lines.

### Directives, Laws and Regulations

**2N Access Unit M** conforms to the following directives and regulations:

#### EU

- 2012/19/EU on waste electrical and electronic equipment

- 2014/53/EU for radio equipment
- 2011/65/EU on the restriction of the use of certain hazardous substances in electrical and electronic equipment

## Industry Canada

This Class B digital apparatus complies with Canadian ICES-003/NMB-003.

## Legislation of Thailand

เครื่องโทรคมนาคมและอุปกรณ์นี้  
มีความสอดคล้องตามมาตรฐานหรือขอ  
กำหนดทางเทคนิคของ กสทช.

  
**nabp.**

เครื่องวิทยุคมนาคมนี้ ได้รับยกเว้น ไม่ต้องได้  
รับใบอนุญาตให้มี ใช้ซึ่งเครื่องวิทยุคมนาคม  
หรือตั้งสถานีวิทยุคมนาคมตามประกาศ กสทช.  
เรื่อง เครื่องวิทยุคมนาคม และสถานีวิทยุ  
คมนาคมที่ได้รับยกเว้นไม่ต้องได้รับใบอนุญาต  
วิทยุคมนาคมตามพระราชบัญญัติวิทยุคมนาคม  
พ.ศ. 2498



**nabp.** โทรคมนาคม  
กำกับดูแลเพื่อประชาชน  
Call Center 1200 (InSW)

## Legislation of Japan

本製品は、特定無線設備の技術基準適合証明を受けています。

この装置は、クラス B 機器です。この装置は、住宅環境で使用この装置は、クラス B 機器です。この装置は、住宅環境で使用することを目的としていますが、この装置がラジオやテレビジョン受信機に近接して使用されると、受信障害を引き起こすことがあります。取扱説明書に従って正しい取り扱いをして下さい。  
VCCI - B

本製品は、シールドネットワークケーブル(STP)を使用して接続してください。また適切に接地してください。

本製品は電気通信事業者（移動通信会社、固定通信会社、インターネットプロバイダ等）の通信回線（公衆無線 LAN を含む）に直接接続することができません。本製品をインターネットに接続する場合は、必ずルータ等を経由し接続してください。

## Electric Waste and Used Battery Pack Handling



Do not place used electric devices and battery packs into municipal waste containers. An undue disposal thereof might impair the environment!

Deliver your expired household electric appliances and battery packs removed from them to dedicated dumpsites or containers or give them back to the dealer or manufacturer for environmental-friendly disposal.

## General Instructions and Cautions

a). The dealer or manufacturer shall take the product back free of charge and without requiring another purchase. Make sure that the devices to be disposed of are complete.

Do not throw battery packs into fire. Battery packs may not be taken into parts or short-circuited either.



2N Access Unit M – Installation Manual

© 2N Telekomunikace a. s., 2026

**2N.com**