



# 2N Access Unit 2.0

## Installation Manual

Manuals for previous firmware versions are at <https://wiki.2n.com/acui/>.



# Table of Contents

<b>Symbols and Terms Used</b> .....	<b>4</b>
<b>Product Description</b> .....	<b>5</b>
Basic Features .....	5
Product Versions .....	6
Accessories .....	12
Accessories for Installation .....	12
Frames .....	14
Extenders .....	17
Power Supply .....	25
Other accessories .....	25
Package Completeness Check .....	30
Module / Frame Package Completeness Check .....	30
<b>Installation</b> .....	<b>32</b>
Mechanical Installation .....	32
Into classic bricks, hollow bricks, thermally insulated fronts, etc. ....	33
Into plasterboard .....	51
Surface Installation .....	65
Electric Installation .....	81
Stand-alone access unit power supply installation .....	81
Power supply installation for access unit with an extending module .....	81
Power Supply .....	82
Cabling Description .....	83
Board Versions .....	88
LAN Connection .....	93
Overvoltage Protection .....	94
Installation Completion .....	97
Frame Attachment .....	97
Most Frequent Installation Errors .....	97
<b>Main and Extending Modules</b> .....	<b>99</b>
Module Interconnection .....	99
Module Power Supply .....	100
Module Specifications .....	102
125 kHz RFID Card Reader Module .....	102
13.56 MHz, NFC RFID Card Reader Module .....	103
Secured 13.56 MHz NFC RFID Card Reader Module .....	103
Bluetooth & 125 kHz, 13.56 MHz, NFC RFID Card Reader Module .....	104
Bluetooth & 125 kHz, secured 13.56 MHz, NFC RFID Card Reader Module .....	104
Touch Keypad & 125 kHz, 13.56 MHz, NFC RFID Card Reader Module .....	105
Touch Keypad & 125 kHz, secured 13.56 MHz, NFC RFID Card Reader Module .....	105
Touch Keypad & Bluetooth & 125 kHz, 13.56 MHz, NFC RFID Card Reader Module .....	106
Touch Keypad & Bluetooth & 125 kHz, secured 13.56 MHz, NFC RFID Card Reader Module .....	107
Touch Keypad Module .....	107
Biometric Fingerprint Reader Module .....	108
Touch Display Module .....	108
Keypad Module .....	109
I/O Module .....	109
Wiegand Module .....	111
Security Relay .....	115
OSDP Module .....	117
Infopanel Module .....	121
<b>Brief Guidelines</b> .....	<b>122</b>
IP Address Retrieval .....	122
IP Address Retrieval Using 2N IP Utility .....	122

IP Address Retrieval Using the RESET button .....	123
Access to web device configuration .....	124
Password Change .....	124
Recommended browsers .....	125
Firmware Update .....	125
Device Restart .....	125
Restart Using Web Configuration Interface .....	126
Restart Using RESET Button .....	126
Factory Default Reset .....	126
Factory Default Reset via Web Configuration Interface .....	126
Factory Default Reset with RESET Button .....	126
Configuration via Hardware .....	127
Device Restart .....	127
<b>Device Control .....</b>	<b>128</b>
Colour Signalling .....	128
<b>Maintenance - Cleaning .....</b>	<b>129</b>
<b>Troubleshooting .....</b>	<b>130</b>
<b>Technical Parameters .....</b>	<b>131</b>
<b>General Instructions and Cautions .....</b>	<b>134</b>
Directives, Laws and Regulations .....	134
EU .....	134
Industry Canada .....	135
Legislation of Thailand .....	135
Electric Waste and Used Battery Pack Handling .....	135

## Symbols and Terms Used

The following symbols and pictograms are used in the manual:



**DANGER**

**Always abide** by this information to prevent persons from injury.



**WARNING**

**Always abide** by this information to prevent damage to the device.



**CAUTION**

**Important information** for system functionality.



**TIP**

**Useful information** for quick and efficient functionality.



**NOTE**

Routines or advice for efficient use of the device.

# Product Description

In this section, we introduce the **2N Access Unit 2.0** product, outline its application options and highlight the advantages following from its use.

## Basic Features

**2N Access Unit 2.0** is an elegant and reliable IP system equipped with a number of useful functions. **2N Access Unit 2.0** is designed as a robust, mechanically resistant access system, which withstands any weather conditions without requiring additional accessories.

**2N Access Unit 2.0** is a modular access system that meets all individual user configuration needs. Unlike other access systems available on the market, **2N Access Unit 2.0** is not a single-module system with a fixed functionality, but represents a user friendly modular system, allowing the user to assemble required modules and accessories on a plug&play basis. This approach allows for individual system configurations and also leaves space for additional functionality if necessary.

The **numeric keypad module** allows you to use the device as a code lock for lock switch activation. The **integrated card reader module** provides the access control functionality using an RFID card. With additional software features, functions other than the door lock can be RFID card controlled too. The electric lock switch can be controlled via a numeric keypad or automation. The switch can be completed with additional output modules if necessary. A wide range of settings allow for a variety of applications.

The installation of **2N Access Unit 2.0** is very easy. All you have to do is assemble the required modules and connect the system to your LAN via a mains cable. Feed the device from a 12 V power supply or your PoE supporting LAN.

Use a PC equipped with any internet browser to configure **2N Access Unit 2.0**. The modules are plug&play, so they do not have to be configured manually. Use **2N Access Commander** to bulk manage extensive access system installations easily.

### Advantages of Use **2N Access Unit 2.0**:

- Elegant design,
- Cover rating,
- Variable installation options (flush mounting into brick/plasterboard walls, surface installation),
- Integrated electric lock switches with wide setting options,
- Integrated RFID card reader module,
- Bluetooth module version with a fingerprint reader or backlit touch keypad,
- Use of multiple modules of the same type - e.g. building entrance/exit card reader,
- Configuration using web interface,
- HTTP server for API configuration,
- SNTP client for server time synchronization,
- SMTP client for e-mail sending,
- TFTP/HTTP client for automated configuration and firmware update,
- LAN (PoE) or external 12 V power supply.

## Product Versions

Extenders (p. 17) need to be used for extending the basic version of the product.



### Part No. 9160341

2N Access Unit 2.0 125 kHz

It provides access control via contactless cards or key fobs.

Supported RFID cards 125 kHz:

- EM4x02
- 



### Part No. 9160341US

Axis Part No. 02137-001

2N Access Unit 2.0 125 kHz

It provides access control via contactless cards or key fobs.

Supported RFID cards 125 kHz:

- EM4x02
- HID Prox



### Part No. 9160342

Axis Part No. 02143-001

2N Access Unit 2.0 13.56 MHz, NFC ready

It provides access control via contactless cards or key fobs. The module supports the following 13.56 MHz cards and/or other carriers (only card serial number is read):

Supported RFID cards 13.56 MHz:

- **ISO14443A** (MIFARE Classic, MIFARE Plus, MIFARE Mini, MIFARE Ultralight, MIFARE DESFire CSN only)
- **ISO14443B** (Calypso)
- **PicoPass** (HID iClass CSN, Picopass)
- **FeliCa** (Standard, Lite)
- **ST SR** (SR, SRI, SRIX)
- **My2N**
- **2N PICard**

## Product Description



### Part No. 9160342-S

Axis Part No. 02142-001

2N Access Unit 2.0 secured 13.56 MHz, NFC ready

It provides access control via contactless cards or key fobs. The module supports the following 13.56 MHz cards and/or other carriers (only card serial number is read):

Supported RFID cards 13.56 MHz:

- **ISO14443A** (MIFARE Classic, MIFARE Plus, MIFARE Mini, MIFARE Ultralight, MIFARE DESFire CSN only)
- **ISO14443B** (Calypso)
- **PicoPass** (HID iClass CSN, Picopass)
- **FeliCa** (Standard, Lite)
- **ST SR** (SR, SRI, SRIX)
- **HID PAC** (HID SEOS, HID iClass SE, iClass SR, HID MIFARE DESFire with SIO, HID MIFARE Classic with SIO)
- **My2N**
- **2N PICard**



### Part No. 916201

Axis Part No. 03089-001

#### 2N Access Unit QR

It provides access control via a QR code.

One blind module is always supplied with the device.



### Part No. 9160311

Axis Part No. 03508-001

2N Access Unit 2.0 Biometric fingerprint reader

Used for verifying human fingerprints for access control and intercom/third party equipment control.



### Part No. 916032

Axis Part No. 02262-001

2N Access Unit 2.0 Touch keypad

The numeric touch keypad module helps you control the lock or other functions with a numeric code. The keypad digits and symbols are backlit.

## Product Description



### Part No. 9160344

Axis Part No. 02138-001

2N Access Unit 2.0 RFID – 125 kHz, 13.56 MHz, NFC

It provides access control via contactless cards or key fobs. The module supports the 125 kHz EM-4100, EM4102 cards. The module also supports the 13.56 MHz cards and/or other carriers.

Supported RFID cards 125 kHz:

- EM4x02
- 

Supported RFID cards 13.56 MHz:

- **ISO14443A** (MIFARE Classic, MIFARE Plus, MIFARE Mini, MIFARE Ultralight, MIFARE DESFire CSN only)
- **ISO14443B** (Calypso)
- **PicoPass** (HID iClass CSN, Picopass)
- **FeliCa** (Standard, Lite)
- **ST SR** (SR, SRI, SRIX)
- **My2N**
- **2N PICard**



### Part No. 9160344-S

Axis Part No. 02146-001

2N Access Unit 2.0 RFID – 125 kHz, secured 13.56 MHz, NFC

It provides access control via contactless cards or key fobs. The module supports the 125 kHz EM-4100, EM4102 cards. The module also supports the 13.56 MHz cards and/or other carriers.

Supported RFID cards 125 kHz:

- EM4x02
- HID Prox

Supported RFID cards 13.56 MHz:

- **ISO14443A** (MIFARE Classic, MIFARE Plus, MIFARE Mini, MIFARE Ultralight, MIFARE DESFire CSN only)
  - **ISO14443B** (Calypso)
  - **PicoPass** (HID iClass CSN, Picopass)
  - **FeliCa** (Standard, Lite)
  - **ST SR** (SR, SRI, SRIX)
  - **HID PAC** (HID SEOS, HID iClass SE, iClass SR, HID MIFARE DESFire with SIO, HID MIFARE Classic with SIO)
  - **My2N**
  - **2N PICard**
-

## Product Description



### Part No. 9160345

Axis Part No. 02772-001

2N Access Unit 2.0 Bluetooth & RFID – 125 kHz, 13.56 MHz, NFC

A combined Bluetooth – card reader module helps you control access using an access code, My2N in your smartphone or an access card. The module supports the 125 kHz and 13.56 MHz cards and/or other carriers.

Supported RFID cards 125 kHz:

- EM4x02
- 

Supported RFID cards 13.56 MHz:

- **ISO14443A** (MIFARE Classic, MIFARE Plus, MIFARE Mini, MIFARE Ultralight, MIFARE DESFire CSN only)
- **ISO14443B** (Calypso)
- **PicoPass** (HID iClass CSN, Picopass)
- **FeliCa** (Standard, Lite)
- **ST SR** (SR, SRI, SRIX)
- **My2N**
- **2N PICard**



### Part No. 9160345-S

Axis Part No. 02773-001

2N Access Unit 2.0 Bluetooth & RFID – 125 kHz, secured 13.56 MHz, NFC

A combined Bluetooth – card reader module helps you control access using an access code, My2N in your smartphone or an access card. The module supports the 125 kHz and 13.56 MHz cards and/or other carriers.

Supported RFID cards 125 kHz:

- EM4x02
- HID Prox

Supported RFID cards 13.56 MHz:

- **ISO14443A** (MIFARE Classic, MIFARE Plus, MIFARE Mini, MIFARE Ultralight, MIFARE DESFire CSN only)
  - **ISO14443B** (Calypso)
  - **PicoPass** (HID iClass CSN, Picopass)
  - **FeliCa** (Standard, Lite)
  - **ST SR** (SR, SRI, SRIX)
  - **HID PAC** (HID SEOS, HID iClass SE, iClass SR, HID MIFARE DES-Fire with SIO, HID MIFARE Classic with SIO)
  - **My2N**
  - **2N PICard**
-

## Product Description



### Part No. 9160346

Axis Part No. 02774-001

2N Access Unit 2.0 Touch keypad & RFID – 125 kHz, 13.56 MHz, NFC

A combined touch keypad – Bluetooth – card reader module helps you control access using a numeric code, contactless cards or key fobs. The module supports the 125 kHz and 13.56 MHz cards and/or other carriers.

Supported RFID cards 125 kHz:

- EM4x02
- 

Supported RFID cards 13.56 MHz:

- **ISO14443A** (MIFARE Classic, MIFARE Plus, MIFARE Mini, MIFARE Ultralight, MIFARE DESFire CSN only)
- **ISO14443B** (Calypso)
- **PicoPass** (HID iClass CSN, Picopass)
- **FeliCa** (Standard, Lite)
- **ST SR** (SR, SRI, SRIX)
- **My2N**
- **2N PICard**



### Part No. 9160346-S

Axis Part No. 02775-001

2N Access Unit 2.0 Touch keypad & Bluetooth & RFID - 125 kHz, 13.56 MHz, NFC

A combined touch keypad – Bluetooth – card reader module helps you control access using a numeric code, contactless cards or key fobs. The module supports the 125 kHz and 13.56 MHz cards and/or other carriers.

Supported RFID cards 125 kHz:

- EM4x02
- HID Prox

Supported RFID cards 13.56 MHz:

- **ISO14443A** (MIFARE Classic, MIFARE Plus, MIFARE Mini, MIFARE Ultralight, MIFARE DESFire CSN only)
- **ISO14443B** (Calypso)
- **PicoPass** (HID iClass CSN, Picopass)
- **FeliCa** (Standard, Lite)
- **ST SR** (SR, SRI, SRIX)
- **HID PAC** (HID SEOS, HID iClass SE, iClass SR, HID MIFARE DES-Fire with SIO, HID MIFARE Classic with SIO)
- **My2N**
- **2N PICard**

## Product Description



### Part No. 9160347

Axis Part No. 02776-001

2N Access Unit 2.0 Touch keypad & Bluetooth & RFID - 125 kHz, 13.56 MHz, NFC

A combined touch keypad – Bluetooth – card reader module helps you control access using an access code, **My2N** in your smartphone or an access card. The module supports the 125 kHz and 13.56 MHz cards and/or other carriers.

Supported RFID cards 125 kHz:

- EM4x02
- 

Supported RFID cards 13.56 MHz:

- **ISO14443A** (MIFARE Classic, MIFARE Plus, MIFARE Mini, MIFARE Ultralight, MIFARE DESFire CSN only)
- **ISO14443B** (Calypso)
- **PicoPass** (HID iClass CSN, Picopass)
- **FeliCa** (Standard, Lite)
- **ST SR** (SR, SRI, SRIX)
- **My2N**
- **2N PICard**



### Part No. 9160347-S

Axis Part No. 02777-001

2N Access Unit 2.0 Touch keypad & Bluetooth & RFID - 125 kHz, secured 13.56 MHz,

A combined touch keypad – Bluetooth – card reader module helps you control access using an access code, **My2N** in your smartphone or an access card. The module supports the 125 kHz and 13.56 MHz cards and/or other carriers.

Supported RFID cards 125 kHz:

- EM4x02
- HID Prox

Supported RFID cards 13.56 MHz:

- **ISO14443A** (MIFARE Classic, MIFARE Plus, MIFARE Mini, MIFARE Ultralight, MIFARE DESFire CSN only)
- **ISO14443B** (Calypso)
- **PicoPass** (HID iClass CSN, Picopass)
- **FeliCa** (Standard, Lite)
- **ST SR** (SR, SRI, SRIX)
- **HID PAC** (HID SEOS, HID iClass SE, iClass SR, HID MIFARE DES-Fire with SIO, HID MIFARE Classic with SIO)
- **My2N**
- **2N PICard**

## Accessories

### Accessories for Installation

**2N Access Unit 2.0** is designed for both outdoor and indoor applications and requires no additional roof.

The 2N IP Verso accessories are compatible with 2N Access Unit 2.0 and 2N Access Unit QR.

Choose the proper frame and, if necessary, other accessories for your particular installation needs.

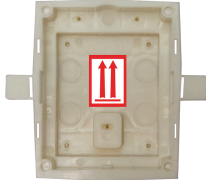

**Part No. 9155014**

Axis Part No. 01284-001

Flush mounting box, 1-module

The box is designed for brick/plasterboard flush mounting of 1-module.

Delivered including accessories for multiple box assemblies.

**Remember to order it together with a 1-module flush mounting frame (9155011/9155011B, 01278-001/01279-001).**

---



**Part No. 9155015**

Axis Part No. 01285-001

Flush mounting box, 2-module

The box is designed for brick/plasterboard flush mounting of 2-module.

Delivered including accessories for multiple box assemblies.

**Remember to order it together with a 2-module flush mounting frame (9155012/9155012B, 01280-001/01281-001).**

---



**Part No. 9155016**

Axis Part No. 01286-001

Flush mounting box, 3-module

The box is designed for brick/plasterboard flush mounting of 3-module.

Delivered including accessories for multiple box assemblies.

**Remember to order it together with a 3-module flush mounting frame (9155013/9155013B, 01282-001/01283-001).**

---

Product Description

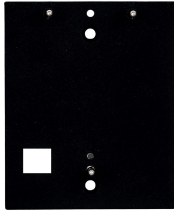

**Part No. 9155061**

Axis Part No. 01293-001

1-module mounting backplate

Mounting backplate for glass/uneven surface mounting of 1 module.

---

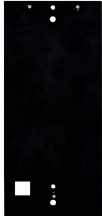

**Part No. 9155062**

Axis Part No. 01294-001

2-module mounting backplate

Mounting backplate for glass/uneven surface mounting of 2 modules.

---



**Part No. 9155063**

Axis Part No. 01295-001

3-module mounting backplate

Mounting backplate for glass/uneven surface mounting of 3 modules.

---

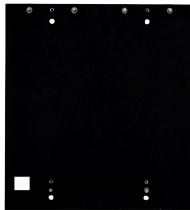

**Part No. 9155064**

Axis Part No. 01296-001

2 x 2-module mounting backplate

Mounting backplate for glass/uneven surface mounting of 2 (w) x 2 (h) modules.

---

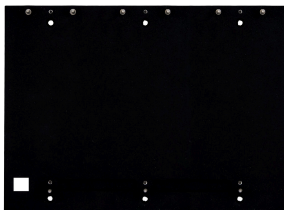

**Part No. 9155065**

Axis Part No. 01297-001

3 x 2-module mounting backplate

Mounting backplate for glass/uneven surface mounting of 3 (w) x 2 (h) modules.

---



**Part No. 9155066**

Axis Part No. 01298-001

2 x 3-module mounting backplate

Mounting backplate for glass/uneven surface mounting of 2 (w) x 3 (h) modules.

---

## Product Description



### **Part No. 9155067**

Axis Part No. 01299-001

3 x 3-module mounting backplate

Mounting backplate for glass/uneven surface mounting of 3 (w) x 3 (h) modules.

---



### **Part No. 9155072**

Axis Part No. 01940-001

2-module slope board

The 2-module slope board is used as a backplate for installations with a tilt of 25°.

---



### **Part No. 916020**

Axis Part No. 01371-001

Cable with RJ45 connector

RJ45 adapter

---



### **Part No. 9155050/9155054/9155055**

Axis Part No. 01267-001/01268-001/01269-001

1/3/5 m interconnecting cable

Interconnection cable for distant module installation.

Only one interconnecting cable is allowed per installation.

The maximum bus length is 7 m.

## **Frames**

The 2N IP Verso accessories are compatible with 2N Access Unit 2.0 and 2N Access Unit QR.

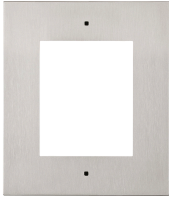

**Part No. 9155011**

Axis Part No. 01278-001

Flush mounting frame, 1 module

Covering frame for the 1-module brick/plasterboard flush mounting box.

The 1-module frame is used, for example:

- When an additional module is added to an existing installation.
- When the module is mounted onto an extended interconnecting cable, for an OUT card reader, for example.

**Remember to order the frame when you order a 1-module flush mounting box (9155014, 01284-001)**

---



**Part No. 9155011B**

Axis Part No. 01279-001

Flush mounting frame, 1 module – black

Covering frame for the 1-module brick/plasterboard flush mounting box.

The 1-module frame is used, for example:

- When an additional module is added to an existing installation.
- When the module is mounted onto an extended interconnecting cable, for an OUT card reader, for example.

**Remember to order the frame when you order a 1-module flush mounting box (9155014, 01284-001)**

---



**Part No. 9155012**

Axis Part No. 01280-001

Flush mounting frame, 2 modules

Covering frame for the 2-module brick/plasterboard flush mounting box.

**Remember to order the frame when you order a 2-module flush mounting box (9155015, 01285-001).**

---



**Part No. 9155012B**

Axis Part No. 01281-001

Flush mounting frame, 2 modules – black

Covering frame for the 2-module brick/plasterboard flush mounting box.

**Remember to order the frame when you order a 2-module flush mounting box (9155015, 01285-001).**

---



**Part No. 9155013**

Axis Part No. 01282-001

Flush mounting frame, 3 modules

Covering frame for the 3-module brick/plasterboard flush mounting box.

**Remember to order the frame when you order a 3-module flush mounting box (9155016, 01286-001).**



**Part No. 9155013B**

Axis Part No. 01283-001

Flush mounting frame, 3-module – black

Covering frame for the 3-module brick/plasterboard flush mounting box.

**Remember to order the frame when you order a 3-module flush mounting box (9155016, 01286-001).**

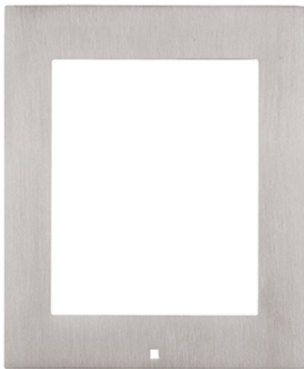

**Part No. 9155021**

Axis Part No. 01287-001

Surface mounting frame, 1 module

The 1-module frame is used, for example:

- when an additional module is added to an existing installation,
- for OUT reader or keypad connection,
- when the module is mounted onto an extended interconnecting cable, for an OUT card reader, for example.



**Part No. 9155021B**

Axis Part No. 01288-001

Surface mounting frame, 1 module – black

The 1-module frame is used, for example:

- when an additional module is added to an existing installation,
- for OUT reader or keypad connection,
- when the module is mounted onto an extended interconnecting cable, for an OUT card reader, for example.

## Product Description



**Part No. 9155022**

Axis Part No. 01289-001

Surface mounting frame, 2 modules

---



**Part No. 9155022B**

Axis Part No. 01290-001

Surface mounting frame, 2 modules – black

---



**Part No. 9155023**

Axis Part No. 01291-001

Surface mounting frame, 3 modules

---



**Part No. 9155023B**

Axis Part No. 01292-001

Surface mounting frame, 3 modules – black

## Extenders



**NOTE**

2N Access Unit 2.0 also supports the 2N IP Verso extending modules.

## Product Description



### **Part No. 9155030**

Axis Part No. 01252-001

2N IP Verso – Infopanel

The Infopanel module helps you place such information into the device installation as house number, opening hours and similar data.

The Infopanel backlight is software controlled.

---



### **Part No. 9155031**

Axis Part No. 01253-001

2N IP Verso – Keypad

The numeric keypad module helps you dial users via their phonebook positions or phone numbers. Also, it helps you control the lock and other functions via a numeric code.

The digits and symbols are backlit.

---



### **Part No. 9155031B**

Axis Part No. 01254-001

2N IP Verso – Keypad – black

The numeric keypad module helps you dial users via their phonebook positions or phone numbers. Also, it helps you control the lock and other functions via a numeric code.

The digits and symbols are backlit.

---



### **Part No. 9155047**

Axis Part No. 01277-001

2N IP Verso – Touch Keypad

The numeric touch keypad module helps you dial users via their phonebook positions or phone numbers, Also, it helps you control the lock and other functions via a numeric code.

The digits and symbols are backlit.

---

## Product Description

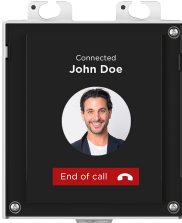

### Part No. 9155036

Axis Part No. 01275-001

2N IP Verso – Touch Display

The touch display module allows visitors to dial users in a smartphone-like way.

In addition the display also features a keypad.



### Part No. 91550941

2N IP Verso 125 kHz

It provides access control via contactless cards or key fobs.

Supported RFID cards 125 kHz:

- EM4x02
- 



### Part No. 91550941US

Axis Part No. 02140-001

2N IP Verso 125 kHz

It provides access control via contactless cards or key fobs.

Supported RFID cards 125 kHz:

- EM4x02
- 



### Part No. 91550942

Axis Part No. 02139-001

2N IP Verso 13.56 MHz, NFC ready

It provides access control via contactless cards or key fobs. The module supports the following 13.56 MHz cards or other carriers:

Supported RFID cards 13.56 MHz:

- **ISO14443A** (MIFARE Classic, MIFARE Plus, MIFARE Mini, MIFARE Ultralight, MIFARE DESFire CSN only)
- **ISO14443B** (Calypso)
- **PicoPass** (HID iClass CSN, Picopass)
- **FeliCa** (Standard, Lite)
- **ST SR** (SR, SRI, SRIX)
- **My2N**
- **2N PICard**

## Product Description



### Part No. 91550942-S

Axis Part No. 02141-001

2N IP Verso 13.56 MHz, secured NFC ready

It provides access control via contactless cards or key fobs. The module supports the following 13.56 MHz cards or other carriers:

Supported RFID cards 13.56 MHz:

- **ISO14443A** (MIFARE Classic, MIFARE Plus, MIFARE Mini, MIFARE Ultralight, MIFARE DESFire CSN only)
- **ISO14443B** (Calypso)
- **PicoPass** (HID iClass CSN, Picopass)
- **FeliCa** (Standard, Lite)
- **ST SR** (SR, SRI, SRIX)
- **HID PAC** (HID SEOS, HID iClass SE, iClass SR, HID MIFARE DESFire with SIO, HID MIFARE Classic with SIO)
- **My2N**
- **2N PICard**



### Part No. 91550451

Axis Part No. 03507-001

2N IP Verso – Biometric Fingerprint Reader

Used for verification of human fingerprints for access control and intercom/third party equipment control.



### Part No. 9155086

Axis Part No. 01712-001

2N IP Verso RFID – secured 13.56 MHz, NFC

It provides access control via contactless cards or key fobs. The module supports the following 13.56 MHz cards or other carriers:

Compatible with firmware version 2.13 and higher.

Supported RFID cards 13.56 MHz:

- **ISO14443A** (MIFARE Classic, MIFARE Plus, MIFARE Mini, MIFARE Ultralight, MIFARE DESFire CSN only)
- **ISO14443B** (Calypso)
- **PicoPass** (HID iClass CSN, Picopass)
- **FeliCa** (Standard, Lite)
- **ST SR** (SR, SRI, SRIX)
- **My2N**
- **2N PICard**

## Product Description



### Part No. 91550945

Axis Part No. 02778-001

2N IP Verso Bluetooth & RFID – 125 kHz, 13.56 MHz, NFC

A combined Bluetooth & card reader module helps you control access using a numeric code, contactless cards or key fobs. The module supports the 125 kHz and 13.56 MHz cards and/or other carriers.

Supported RFID cards 125 kHz:

- EM4x02
- 

Supported RFID cards 13.56 MHz:

- **ISO14443A** (MIFARE Classic, MIFARE Plus, MIFARE Mini, MIFARE Ultralight, MIFARE DESFire CSN only)
- **ISO14443B** (Calypso)
- **PicoPass** (HID iClass CSN, Picopass)
- **FeliCa** (Standard, Lite)
- **ST SR** (SR, SRI, SRIX)
- **My2N**
- **2N PICard**



### Part No. 91550945-S

Axis Part No. 02444-001

2N IP Verso Bluetooth & RFID – 125 kHz, secured 13.56 MHz, NFC

A combined Bluetooth – card reader module helps you control access using an access code, My2N in your smartphone or an access card. The module supports the 125 kHz and 13.56 MHz cards and/or other carriers.

Supported RFID cards 125 kHz:

- EM4x02
- 

Supported RFID cards 13.56 MHz:

- **ISO14443A** (MIFARE Classic, MIFARE Plus, MIFARE Mini, MIFARE Ultralight, MIFARE DESFire CSN only)
  - **ISO14443B** (Calypso)
  - **PicoPass** (HID iClass CSN, Picopass)
  - **FeliCa** (Standard, Lite)
  - **ST SR** (SR, SRI, SRIX)
  - **HID PAC** (HID SEOS, HID iClass SE, iClass SR, HID MIFARE DESFire with SIO, HID MIFARE Classic with SIO)
  - **My2N**
  - **2N PICard**
-

## Product Description



### Part No. 91550946

Axis Part No. 02779-001

2N IP Verso Touch keypad & RFID – 125 kHz, 13.56 MHz, NFC

A combined touch keypad – card reader module helps you control access using a numeric code, contactless cards or key fobs. The module supports the 125 kHz and 13.56 MHz cards and/or other carriers.

Supported RFID cards 125 kHz:

- EM4x02
- 

Supported RFID cards 13.56 MHz:

- **ISO14443A** (MIFARE Classic, MIFARE Plus, MIFARE Mini, MIFARE Ultralight, MIFARE DESFire CSN only)
- **ISO14443B** (Calypso)
- **PicoPass** (HID iClass CSN, Picopass)
- **FeliCa** (Standard, Lite)
- **ST SR** (SR, SRI, SRIX)
- **My2N**
- **2N PICard**

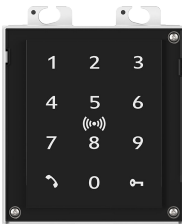

### Part No. 91550946-S

Axis Part No. 02443-001

2N IP Verso Touch keypad & RFID – 125 kHz, secured 13.56 MHz, NFC

A combined touch keypad – card reader module helps you control access using a numeric code, contactless cards or key fobs. The module supports the 125 kHz and 13.56 MHz cards and/or other carriers.

Supported RFID cards 125 kHz:

- EM4x02
- HID Prox

Supported RFID cards 13.56 MHz:

- **ISO14443A** (MIFARE Classic, MIFARE Plus, MIFARE Mini, MIFARE Ultralight, MIFARE DESFire CSN only)
  - **ISO14443B** (Calypso)
  - **PicoPass** (HID iClass CSN, Picopass)
  - **FeliCa** (Standard, Lite)
  - **ST SR** (SR, SRI, SRIX)
  - **HID PAC** (HID SEOS, HID iClass SE, iClass SR, HID MIFARE DESFire with SIO, HID MIFARE Classic with SIO)
  - **My2N**
  - **2N PICard**
-

## Product Description



### Part No. 91550947

Axis Part No. 02781-001

2N IP Verso Touch keypad & Bluetooth & RFID – 125 kHz, 13.56 MHz, NFC

A combined touch keypad – Bluetooth – card reader module helps you control access using an access code, My2N in your smartphone or an access card. The module supports the 125 kHz and 13.56 MHz cards and/or other carriers.

Supported RFID cards 125 kHz:

- EM4x02
- 

Supported RFID cards 13.56 MHz:

- **ISO14443A** (MIFARE Classic, MIFARE Plus, MIFARE Mini, MIFARE Ultralight, MIFARE DESFire CSN only)
- **ISO14443B** (Calypso)
- **PicoPass** (HID iClass CSN, Picopass)
- **FeliCa** (Standard, Lite)
- **ST SR** (SR, SRI, SRIX)
- **My2N**
- **2N PICard**



### Part No. 91550947-S

Axis Part No. 02782-001

2N IP Verso Touch keypad & Bluetooth & RFID - 125 kHz, secured 13.56 MHz, NFC

A combined touch keypad – Bluetooth – card reader module helps you control access using an access code, My2N in your smartphone or an access card. The module supports the 125 kHz and 13.56 MHz cards and/or other carriers.

Supported RFID cards 125 kHz:

- EM4x02
- HID Prox

Supported RFID cards 13.56 MHz:

- **ISO14443A** (MIFARE Classic, MIFARE Plus, MIFARE Mini, MIFARE Ultralight, MIFARE DESFire CSN only)
  - **ISO14443B** (Calypso)
  - **PicoPass** (HID iClass CSN, Picopass)
  - **FeliCa** (Standard, Lite)
  - **ST SR** (SR, SRI, SRIX)
  - **HID PAC** (HID SEOS, HID iClass SE, iClass SR, HID MIFARE DES-Fire with SIO, HID MIFARE Classic with SIO)
  - **My2N**
  - **2N PICard**
-

## Product Description



### **Part No. 9155039**

Axis Part No. 01261-001

2N IP Verso – Blind Panel

The blind panel module helps fill up redundant space in installations.

The main unit is supplied with one blind panel module.

---



### **Part No. 9155034**

Axis Part No. 01257-001

I/O Module

The module provides logical inputs and outputs for integration of sensors or other devices.

The module is installed under another module, i.e. needs no separate position.

---



### **Part No. 9155037**

Axis Part No. 01259-001

Wiegand Module

The Wiegand module helps you interconnect your system with other systems via the Wiegand interface.

The module is installed under another module, i.e. needs no separate position.

---

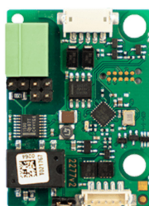

### **Part No. 91550371**

Axis Part No. 02577-001

OSDP Module

The OSDP module provides OSDP communication with a connected OSDP device (control panel, door controller) and **2N Access Unit 2.0** (placed outside).

The module is installed under another module, i.e. needs no separate position.

---

## Product Description

### **Part No. 9159010**



Axis Part No. 01386-001

Security Relay

A handy add-on that significantly enhances security. It prevents lock tampering.

To be installed between the protected device from which it is also powered and the lock controlled by it.

---

### **Part No. 9155198SET**



Axis Part No. 01975-001

Security Package for 2N Devices

The security package provides increased door security.

The safety package includes a safety relay, a protection switch and an I/O module.

## Power Supply

### **Part No. 91378100E (with EU cable)**



### **Part No. 91378100US (with US cable)**

Axis Part No. 01403-001

One-port PoE injector

For intercom supply via Ethernet cable where the PoE switch is absent.

---

### **Part No. 91341481E (with EU cable)**



### **Part No. 91341481US (with US cable)**

Axis Part No. 02520-001

Stabilized 12 V / 2 A power supply

The supply must be used where PoE is not used.

## Other accessories

## Product Description

### Part No. 9159013



Axis Part No. 02523-001

Departure button

The departure button is connected to the device logic input for opening the door from inside the building.

---

### Part No. 9159012



Axis Part No. 01388-001

Magnetic door contact

Set for installation on a door, enabling the status of door opening to be ascertained. Used where the device is used for door protection, open door detection or forced opening.

---

### Part No. 9134173



Axis Part No. 01384-001

MIFARE RFID chip card, 13.56 Hz

RFID chip card, MIFARE Classic 1k, 13.56 MHz.

---

### Part No. 9134174



Axis Part No. 01385-001

MIFARE RFID chip fob, 13.56 MHz

RFID chip fob, MIFARE Classic 1k, 13.56 MHz.

---

### Part No. 9134165E



Axis Part No. 01395-001

EM RFID chip card, 125 Hz

RFID chip card, type EM4100, 125 kHz.

---

## Product Description



### **Part No. 9134166E**

Axis Part No. 01396-001

EM RFID chip fob, 125 kHz

RFID chip fob, type EM4100, 125 kHz.

---

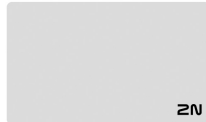

### **Part No. 11202601**

Axis Part No. 02787-001

MIFARE DESFire RFID chip card, 13.56 MHz

RFID chip fob, type MIFARE DESFire EV3 4 K, 13.56 MHz (ISO/IEC14443A).

Suitable for data encryption in PICard Commander.

The package includes 10 pieces.

---



### **Part No. 11202602**

Axis Part No. 02788-001

MIFARE DESFire RFID fob, 13.56 MHz

RFID fob, type MIFARE DESFire EV3 4 K, 13.56 MHz (ISO/IEC14443A).

Suitable for data encryption in PICard Commander.

The package includes 10 pieces.

---



### **Part No. 9137420E**

Axis Part No. 01399-001

External RFID reader, 125 kHz

External RFID card reader connectable to a PC via a USB interface.

Suitable for system administration and adding of EM41xx cards (125 kHz) using the device web configuration or PICard Commander.

---

## Product Description



### Part No. 9137421E

Axis Part No. 01399-001

External RFID reader, 13.56 MHz + 125 kHz, NFC/HCE

External RFID card reader connectable to a PC via a USB interface.

Suitable for system administration and adding of 13.56 MHz/125 kHz cards and Android devices with NFC/HCE support using the device web configuration or the Access Commander.

Suitable for uploading of MIFARE DESFire cards into the PICard Commander encryption application.

The following RFID cards can be read:

Supported RFID cards 125 kHz:

- EM4x02
- 

Supported RFID cards 13.56 MHz:

- **ISO14443A** (MIFARE Classic, MIFARE Plus, MIFARE Mini, MIFARE Ultralight, MIFARE DESFire CSN only)
- **ISO14443B** (Calypso)
- **PicoPass** (HID iClass CSN, Picopass)
- **FeliCa** (Standard, Lite)
- **ST SR** (SR, SRI, SRIX)
- **My2N**
- **2N PICard**

The device can also read the 13.56 MHz 2N PICard RFID cards.

---

## Product Description



### Part No. 9137424E

Axis Part No. 01527-001

External secured RFID reader, 13.56 MHz + 125 kHz, NFC/HCE

External secured RFID card reader connectable to a PC via a USB interface.

Suitable for system administration and adding of 13.56 MHz/125 kHz cards and Android devices with NFC/HCE support using the device web configuration or the Access Commander.

Suitable for uploading of MIFARE DESFire cards into the PICard Commander encryption application.

The following RFID cards can be read:

Supported RFID cards 125 kHz:

- EM4x02
- HID Prox

Supported RFID cards 13.56 MHz:

- **ISO14443A** (MIFARE Classic, MIFARE Plus, MIFARE Mini, MIFARE Ultralight, MIFARE DESFire CSN only)
- **ISO14443B** (Calypso)
- **PicoPass** (HID iClass CSN, Picopass)
- **FeliCa** (Standard, Lite)
- **ST SR** (SR, SRI, SRIX)
- **HID PAC** (HID SEOS, HID iClass SE, iClass SR, HID MIFARE DESFire with SIO, HID MIFARE Classic with SIO)
- **My2N**
- **2N PICard**

---

### Part No. 9137410E



Axis Part No. 01397-001

External IP relay, 1 output

Stand-alone IP relay, which can be controlled from an intercom via HTTP commands and helps control devices from an unlimited distance.

---

### Part No. 9137411E



Axis Part No. 01398-001

External IP relay, 4 outputs, PoE

Stand-alone IP relay, which can be controlled from an intercom via HTTP commands and helps control devices from an unlimited distance.

---

## Product Description

### Part No. 9159014EU/US/UK



Axis Part No. 01404-001

2N 2Wire (set of 2 adaptors and power source for EU/US/UK)

The 2N 2Wire converter allows you to use the existing 2-wire cabling from your original doorbell or door intercom for connecting any IP device. You do not have to configure anything, all you need is one 2N 2Wire unit at each end of the cable and a power supply connected to at least one of these units. The 2N 2Wire unit then provides PoE power not only to the second converter, but to all of the connected IP end devices.

---

### Part No. 9160501

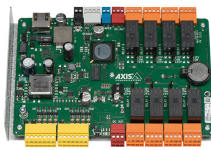

Axis Part No. 0820-001

AXIS A9188 Network I/O Relay Module

The relay is part of the lift access solution. One relay can control up to 8 floors. Intercom or access unit can be interconnected with up to 8 AXIS A9188 lift relays. The solution is thus suitable for up to 64 floors.

---

### Part No. 9154004



Axis Part No. 01479-001

Water-proof metal button

Suitable for internal RFID card reader.

## Package Completeness Check

Please check the product delivery before installation. Contents:

1x **2N Access Unit 2.0**

---

1x Certificate of ownership

---

1x Quick Start manual

---

1x Hex key

## Module / Frame Package Completeness Check

The package of modules for **2N Access Unit 2.0** includes:

## Product Description

3x 3 x 8 mm stainless steel thread-forming lens head screw for plastic

The package of frames for **2N Access Unit 2.0** includes:

**Part Nos. 9155011, 9155011B, 9155012, 9155012B, 9155013, 9155013B**

**Axis Part Numbers 01278-001, 01279-001, 01280-001, 01281-001, 01282-001, 01283-001**

---

3x 4 x 20 mm stainless steel thread-forming lens head screw for plastic

**Part Nos. 9155021, 9155021B, 9155022, 9155022B, 9155023, 9155023B**

**Axis Part Numbers 01287-001, 01288-001, 01289-001, 01290-001, 01291-001, 01292-001**

---

2x 4 x 50 mm stainless steel flat head screw

---

2x 8 x 40 mm dowel



### **CAUTION**

If spare accessories other than the specified types are used, the device warranty might become null and void.

# Installation

## Mechanical Installation

### Installation Conditions

**Make sure that the following 2N Access Unit 2.0 installation conditions are met.**

- There must be enough space for the device installation.
- Make sure that the dowel holes have the required diameter. If the diameters are too large, the dowels may get loose! Use the mounting glue to secure the dowels if necessary.
- Do not use low-quality dowels to avoid their falling out of the wall!
- Make sure that the depths of the dowel holes are accurate!
- Before starting the mechanical installation on a selected place, make sure carefully that the preparations associated with it (drilling, wall cutting) cannot damage the electrical, gas, water and other existing wires and pipes.
- The device is designed for vertical wall mounting (perpendicular to the floor) in the height of up to 1350 mm above the floor. If necessary, operate the device in a position other than as aforementioned for a short time only, for quick testing purposes in a servicing center, for example.
- Make sure that the plasterboard interior does not show a pressure value significantly different from that of the room, e.g. that it is not connected with overpressure ventilation. If the difference is too great, separate the device in terms of pressure (using, e.g., a mounting box) and seal the cable passage.
- The device is not designed for environments with increased vibrations such as means of transport, machine rooms and so on.
- The device is not intended for dusty environments and places with unstable humidity and abrupt temperature changes.
- The device may not be exposed to aggressive gas, acid vapors, solvents, etc.
- The device is not intended for direct connection into the Internet/WAN. The device must be connected to the Internet/WAN via a separating active network element (switch/router).
- The device cannot be operated on places exposed to direct sunshine and near heat sources.
- Keep some free space above and below the device to allow air to flow and conduct heat away.
- Having removed the front panel, make sure that no dirt gets inside the product, especially onto the sealing surface.
- Avoid strong electromagnetic radiation on the installation site.
- Make sure that the VoIP connection is configured properly according to the SIP and other VoIP recommendations.
- A set of multiple **2N Access Unit 2.0** units may never be turned after installation. Make sure that the mounting boxes are built in properly in order to need no additional handling after installation.



### CAUTION

- When the proper installation instructions are not met, water might get in and destroy the electronics. As the device circuits are constantly under voltage water leakage causes electrochemical reaction. The manufacturer's warranty shall be void for products damaged in this way!
- Exceeding the allowed operating temperature may not affect the device immediately but leads to premature ageing and lower reliability. For the acceptable range of operating temperatures and relative humidity values refer to [S. Technical Parameters](#).
- Any intentional mechanical damage to the device (drilling, main unit tampering, etc.) results in a loss of warranty.
- The device installation and setting should only be performed by professionally qualified persons.
- The installation and adjustment of this device, including any handling thereof, should only be carried out by persons qualified to do so.

## Installation Tips

- Flush mounting is recommended. It makes the product more elegant looking, more vandal resistant and more secure.
- The mounting box can be purchased in advance. Thus, a building company can be commissioned to do the rough work. The mounting box also helps you put your device exactly in the vertical position.

### **Flush mounting – into classic bricks, hollow bricks, thermally insulated fronts, etc.**

What you need for mounting:

- **2N Access Unit 2.0**
- a properly cut hole as instructed in the box package
- plaster, mounting glue, mounting foam or mortar as necessary
- flush mounting box and frame
  - for 1-modules: box (9155014, 01284-001) frame (9155011/9155011B, 01278-001/01279-001)
  - for 2-modules: box (9155015, 01285-001), frame (9155012/9155012B, 01280-001/01281-001)
  - for 3-modules: box (9155016, 01286-001), frame(9155013/9155013B, 01282-001/01283-001)

To install a device **2N Access Unit 2.0** into a wall, mount the flush mounting box first. Then install the device into it.

### 1-Module Installation

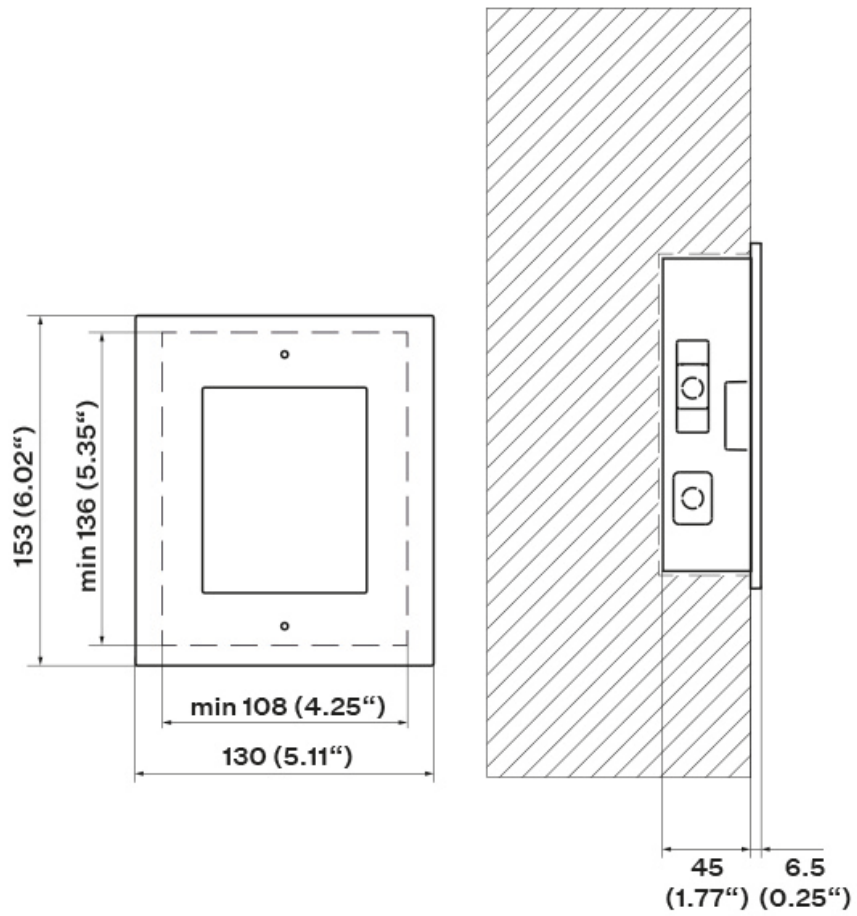

### Box Installation

1x

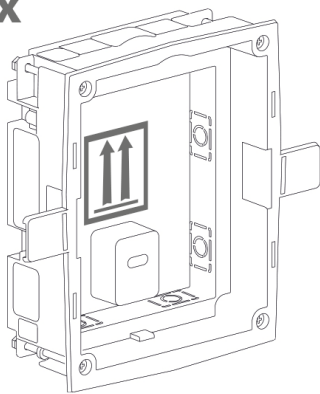

1.

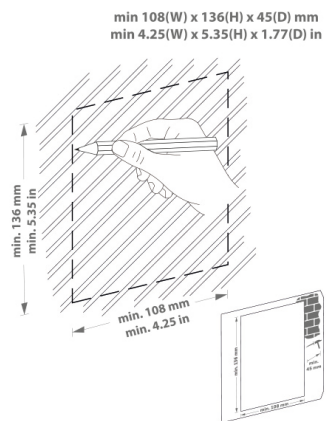

## Installation

2.

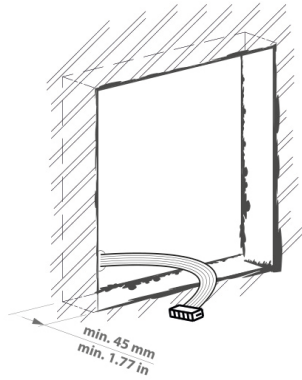

3.

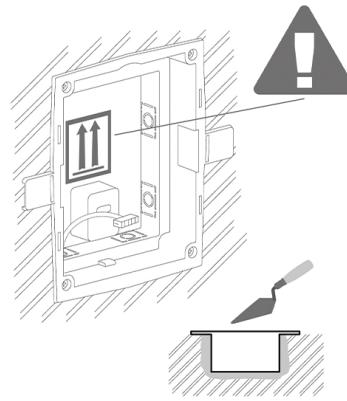

4.

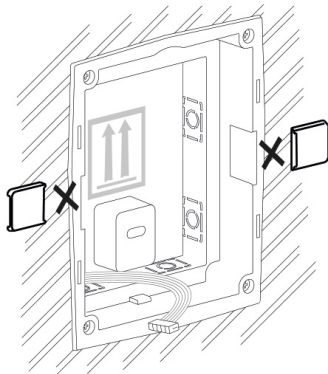

5.

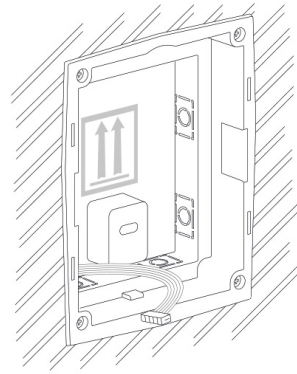

### WARNING

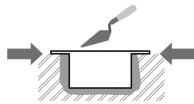

Make sure that the flush mounting box edges are not aligned with the wall but overlap the wall surface. When the proper box installation instructions are not met, water might get in and destroy the device installed. Side stops are used for a correct wall position.



### CAUTION

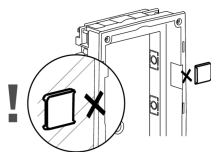

When the walling material has hardened, break off the side stops.

### 1-Module Installation into Box

1.

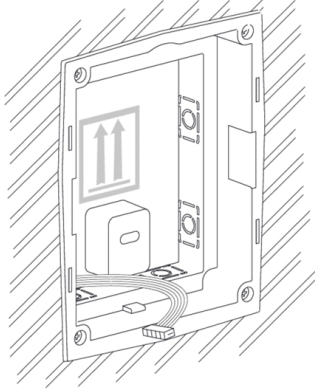

2.

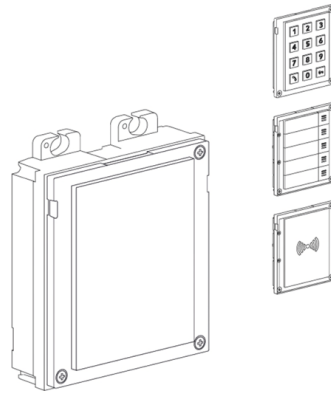

3.

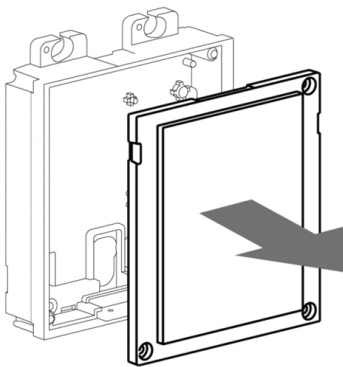

4.

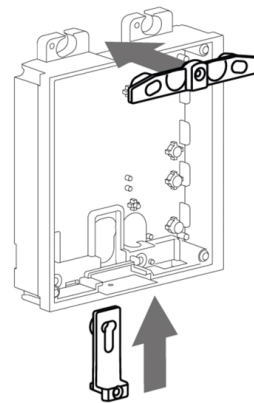

5.

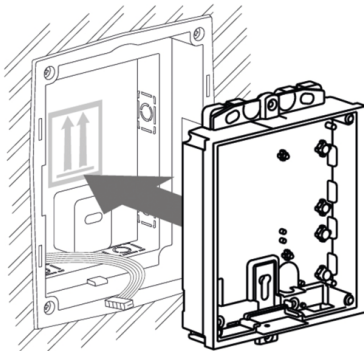

6.

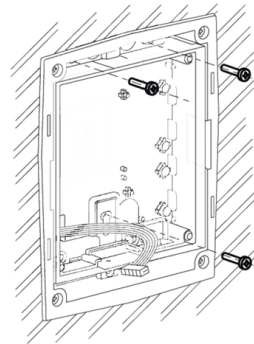

## Installation

7.

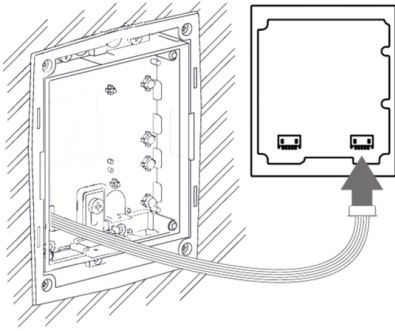

8.

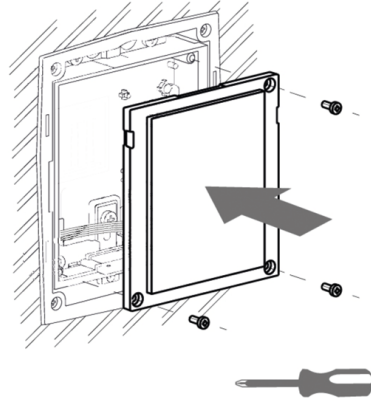

9.

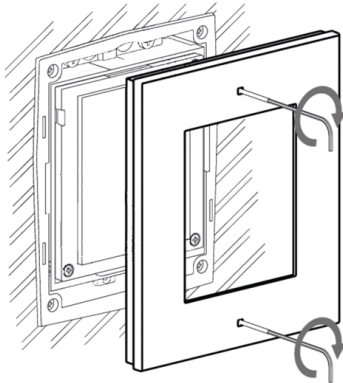

10.

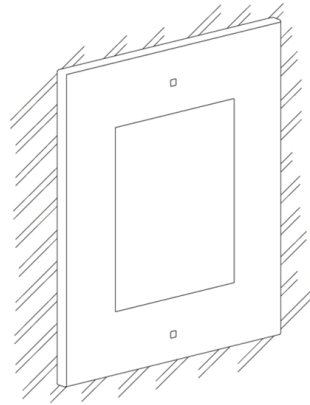

## 2-Module Installation

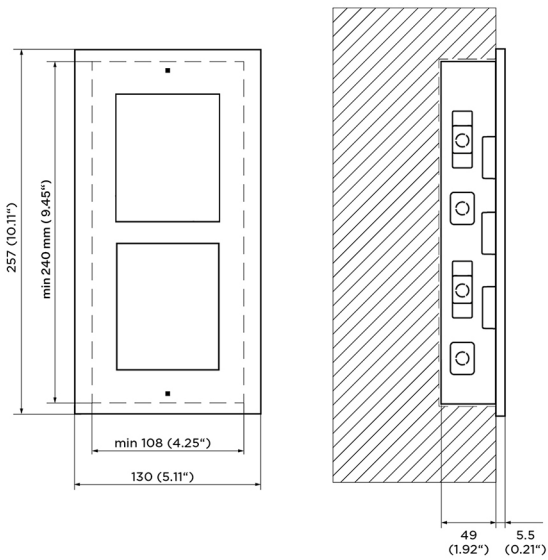

Box Installation

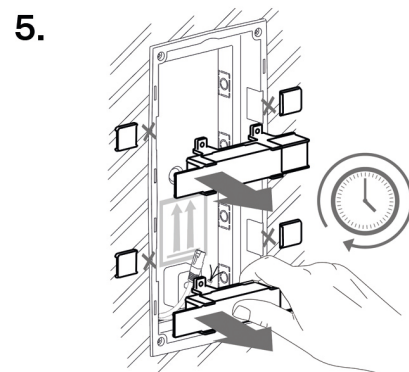
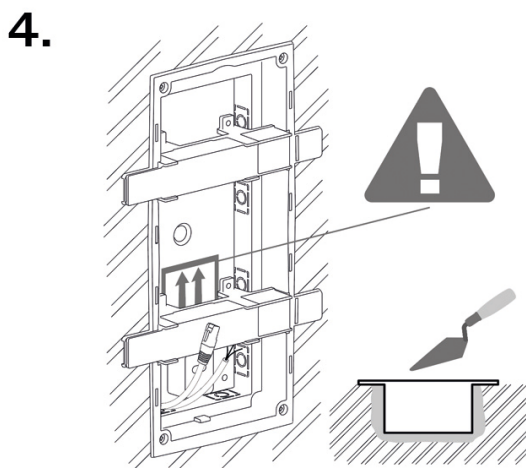
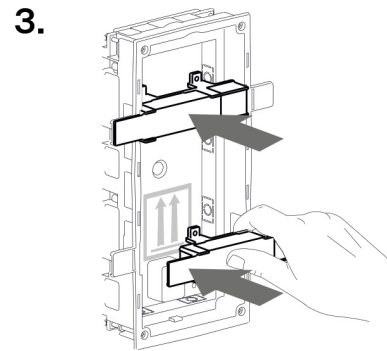
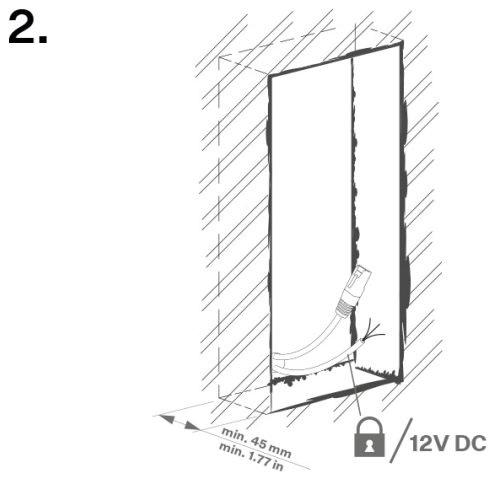
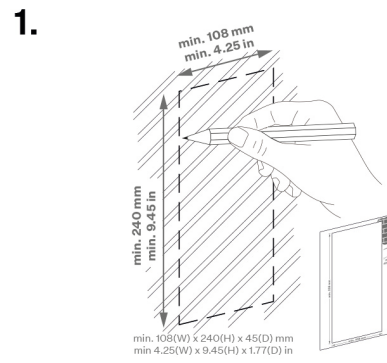
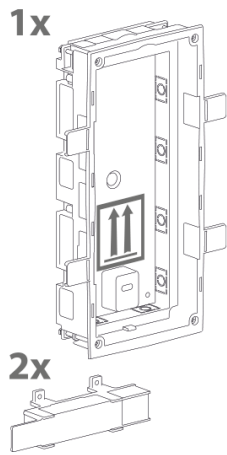

6.

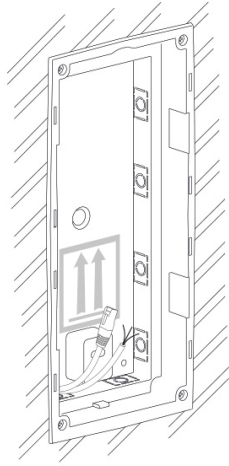

**WARNING**

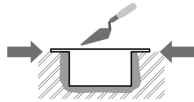

Make sure that the flush mounting box edges are not aligned with the wall but overlap the wall surface. When the proper box installation instructions are not met, water might get in and destroy the device installed. Side stops are used for a correct wall position.



**CAUTION**

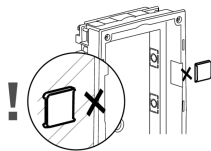

When the walling material has hardened, break off the side stops.

## 2-Module Installation into Box

1.

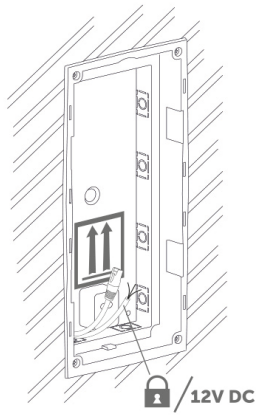

2.

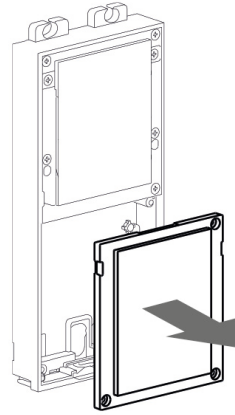

3.

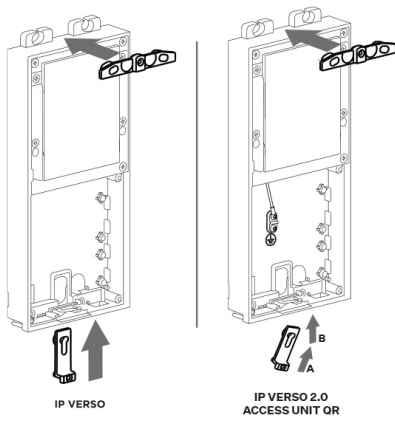

4.

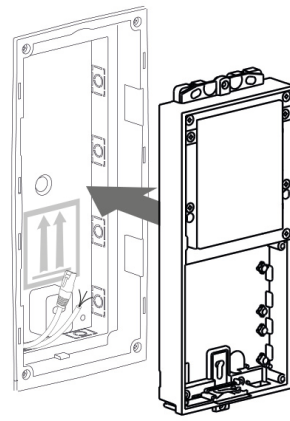

5.

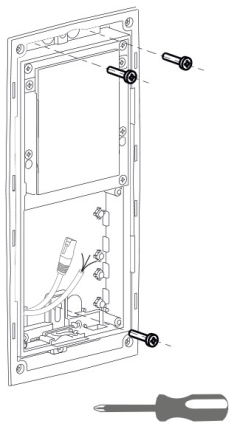

6.

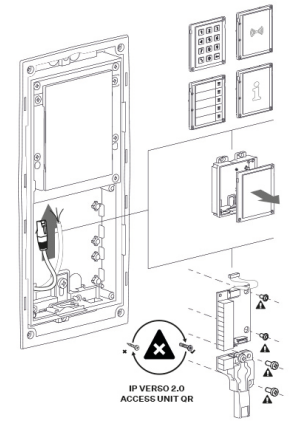

# Installation

7.

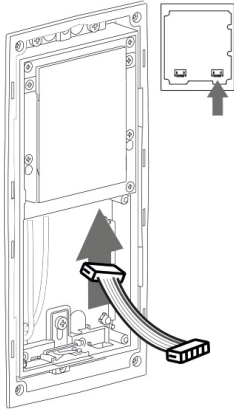

8.

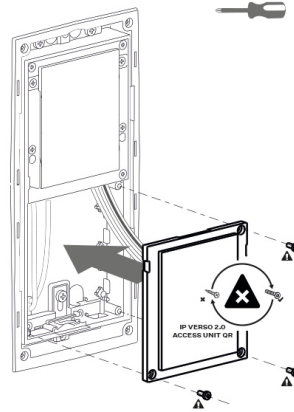

9.

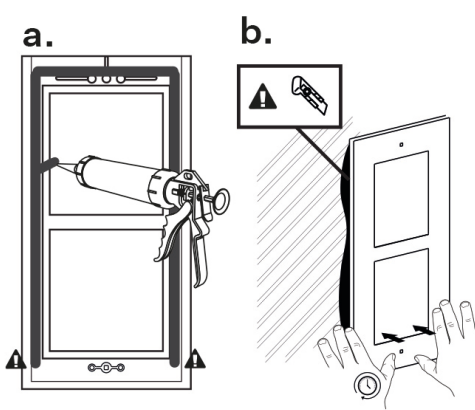

10.

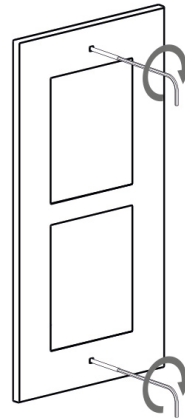

## Installation of Multiple 2-Modules into Box

1.

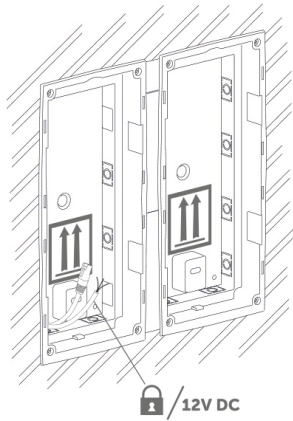

2.

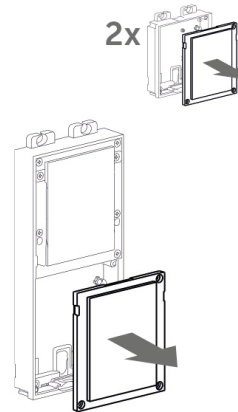

# Installation

3.

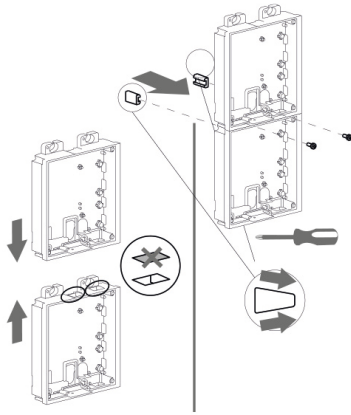

4.

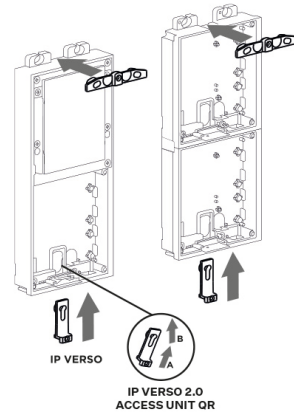

5.



6.

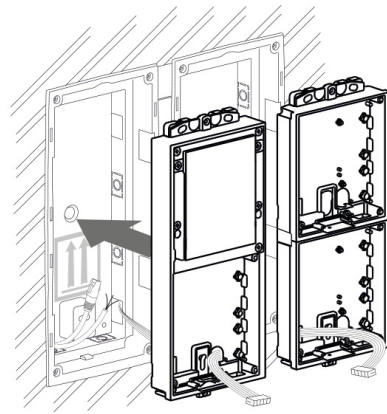

7.

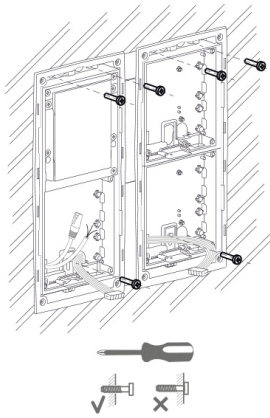

8.

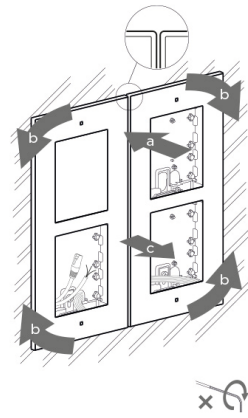

9.

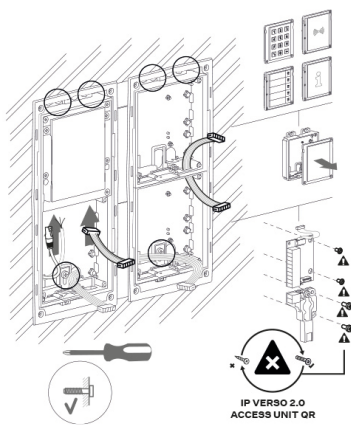

10.

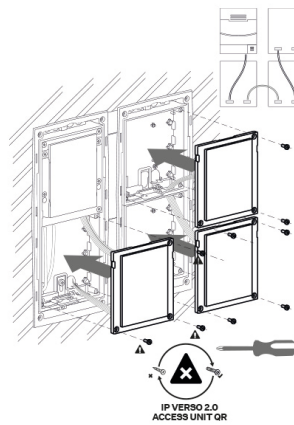

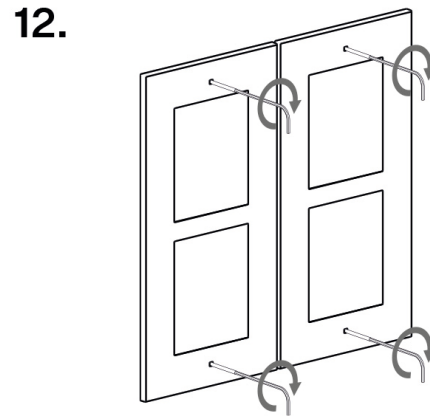
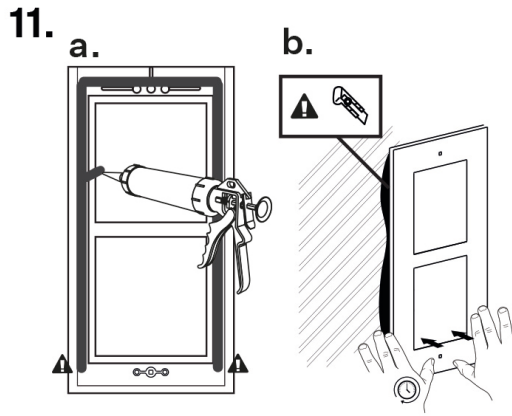

### Frame Attachment

Check the frame sealing before fitting the frame.

Screw the flush mounting frame in the upper and bottom parts.

Hang the surface mounting frame on the hook in the upper part and then screw it tight in the bottom part.

### 3-Module Installation

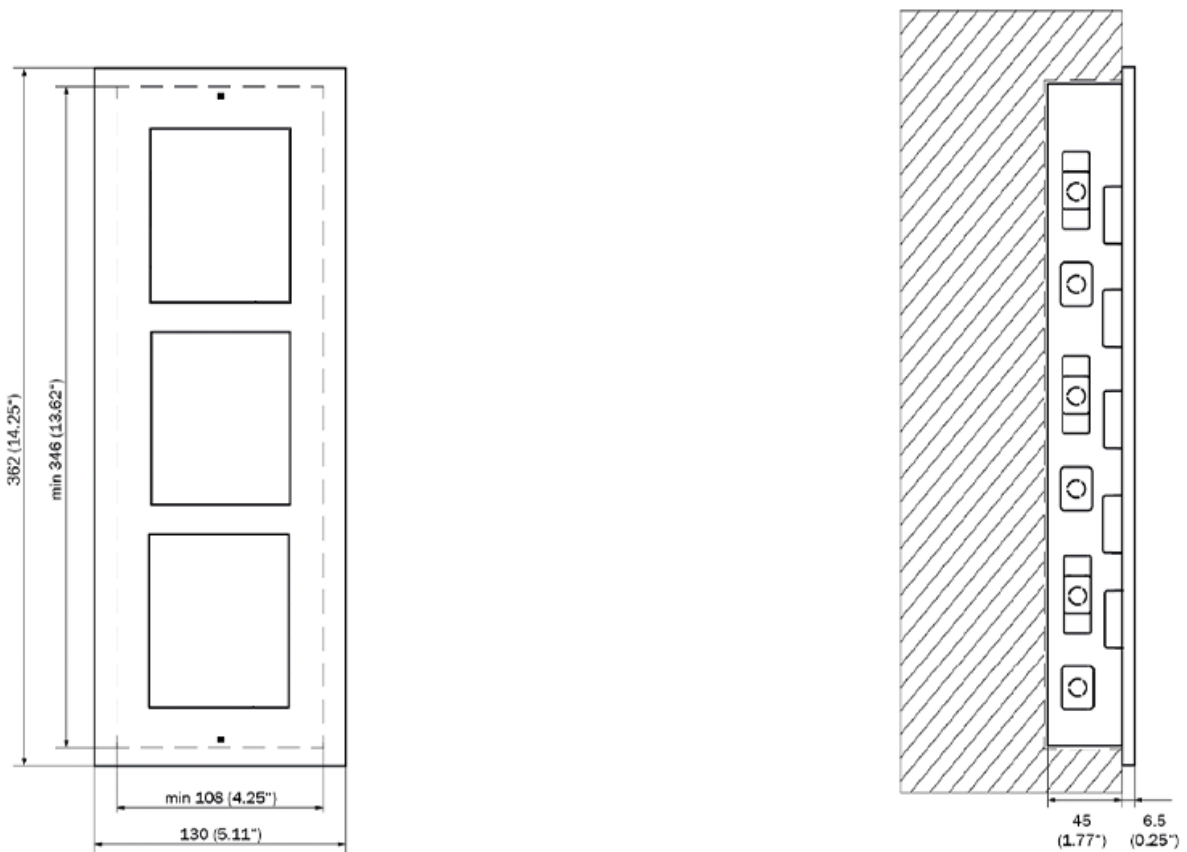

Box Installation

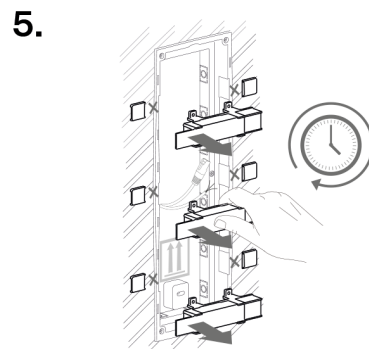
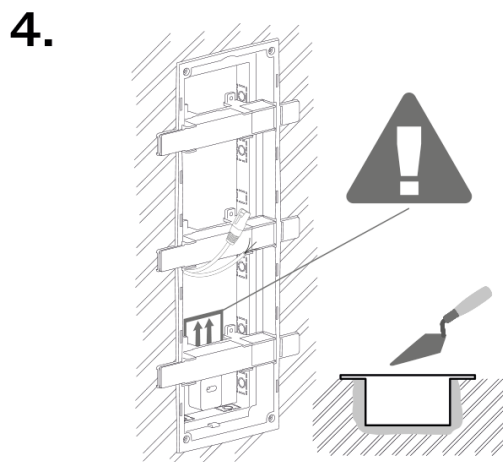
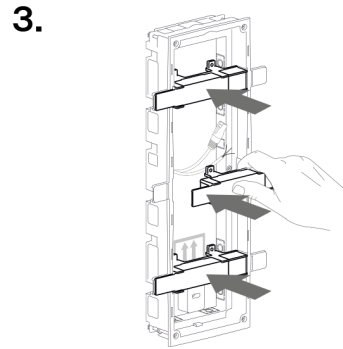
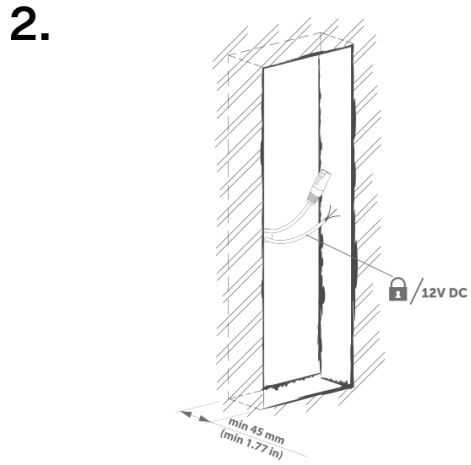
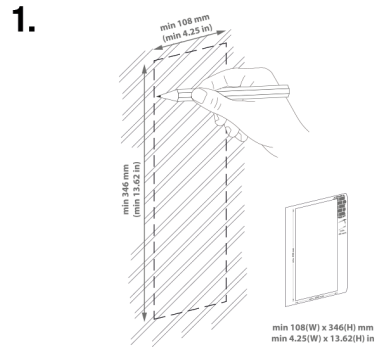
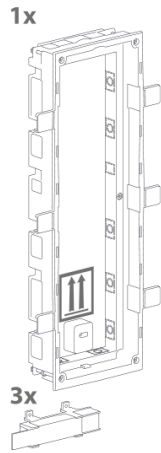

6.

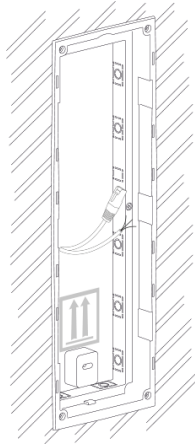

**WARNING**

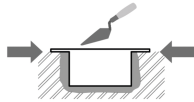

Make sure that the flush mounting box edges are not aligned with the wall but overlap the wall surface. When the proper box installation instructions are not met, water might get in and destroy the device installed. Side stops are used for a correct wall position.



**CAUTION**

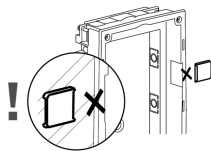

When the walling material has hardened, break off the side stops.

Installation of Multiple 3-Module Boxes Next to Each Other

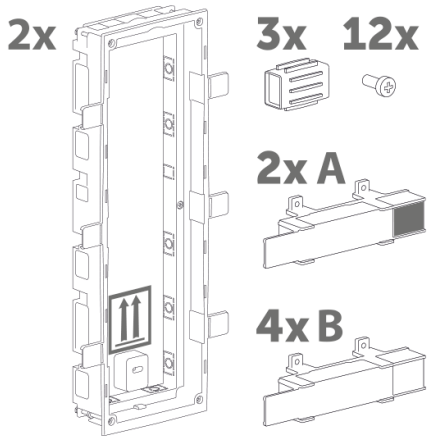
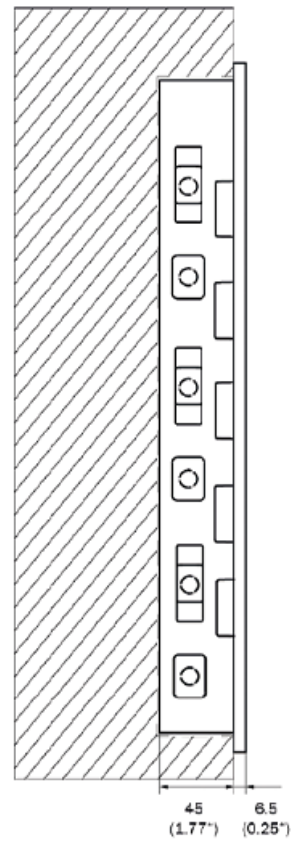
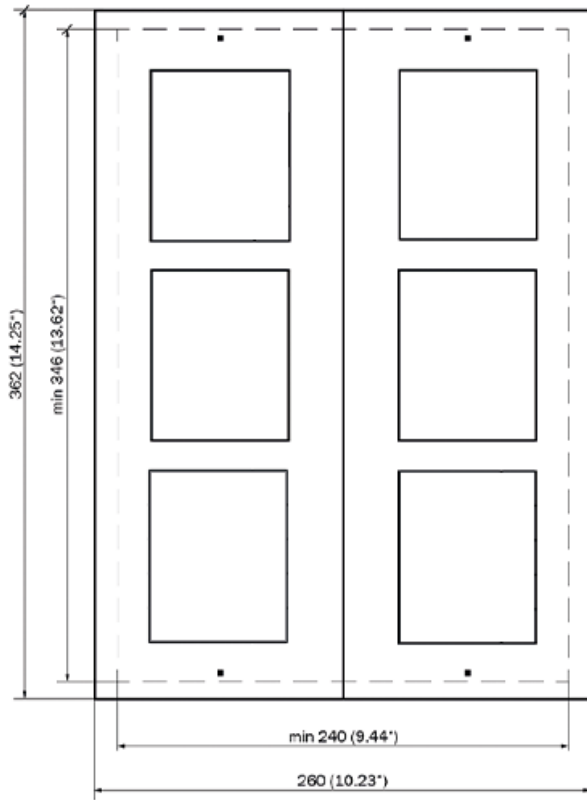

1.

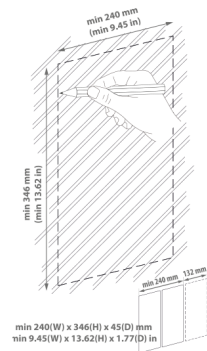

# Installation

2.

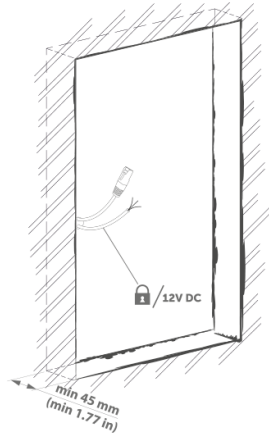

3.

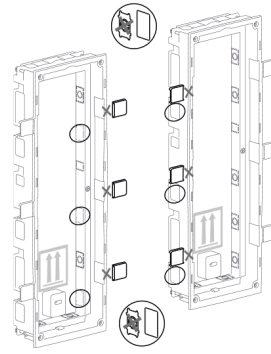

4.

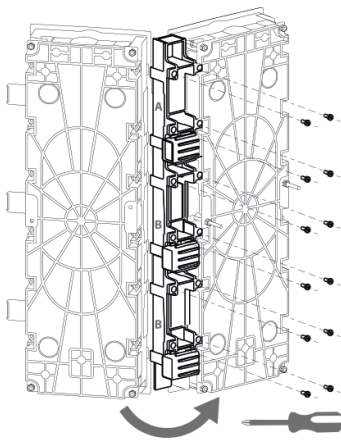

5.

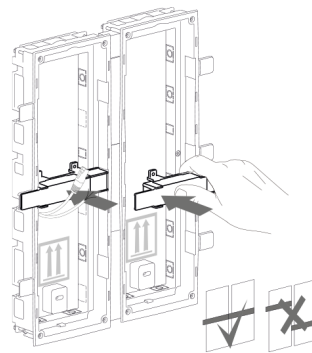

6.

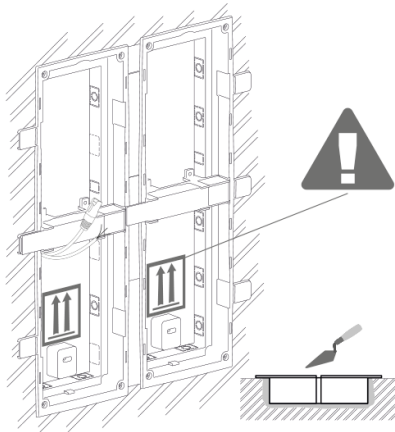

7.

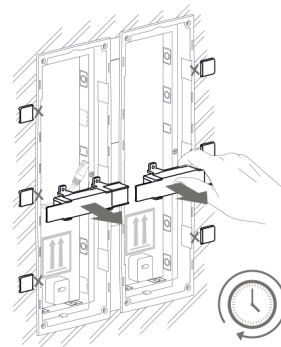

8.

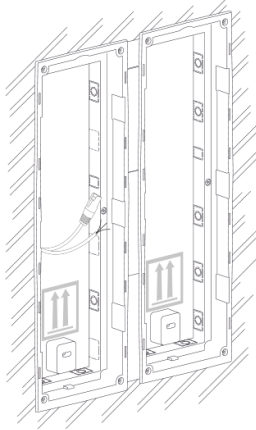

**WARNING**

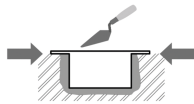

Make sure that the flush mounting box edges are not aligned with the wall but overlap the wall surface. When the proper box installation instructions are not met, water might get in and destroy the device installed. Side stops are used for a correct wall position.



**CAUTION**

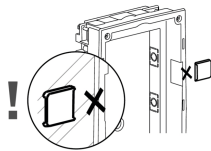

When the walling material has hardened, break off the side stops.

### 3-Module Installation into Box

1.

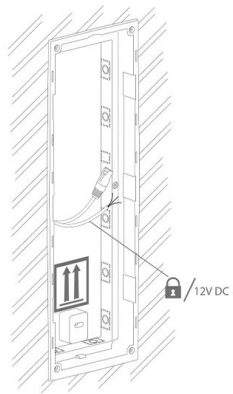

2.

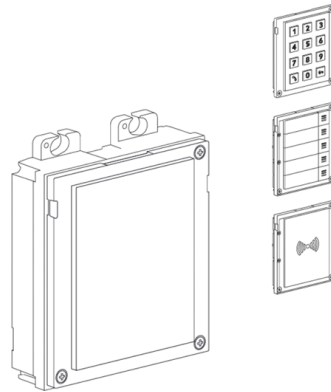

3.

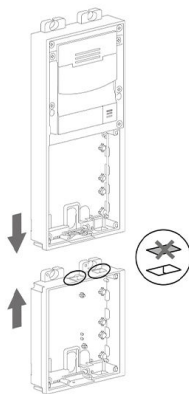

4.

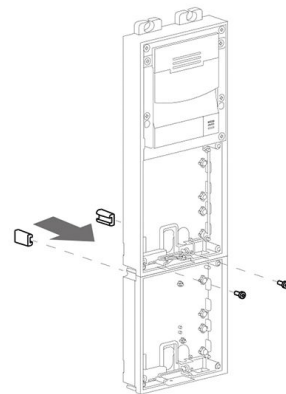

5.

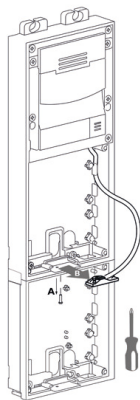

6.

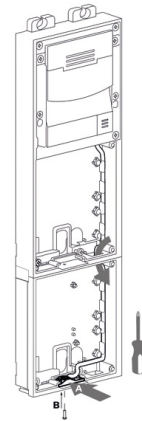

## Installation

7.

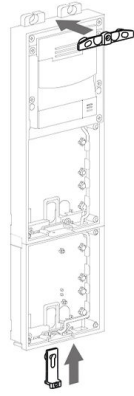

8.

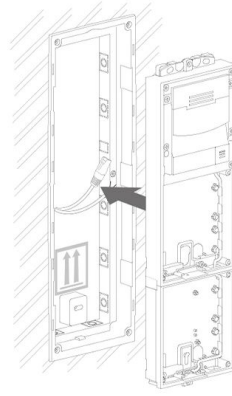

9.

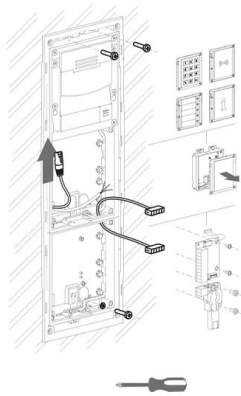

10.

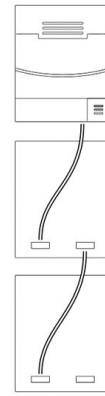

11.

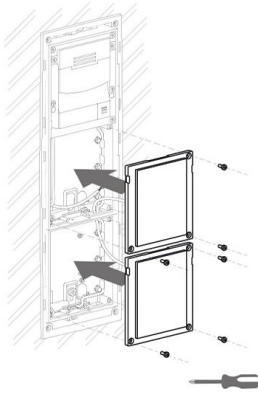

12.



### Frame Attachment

Check the frame sealing before fitting the frame.

Screw the flush mounting frame in the upper and bottom parts.

Hang the surface mounting frame on the hook in the upper part and then screw it tight in the bottom part.

## Flush mounting – into plasterboard

What you need for mounting:

- **2N Access Unit 2.0**
- a properly cut hole as instructed in the box package
- flush mounting box and frame
  - for 1-modules: box (9155014, 01284-001) frame (9155011/9155011B, 01278-001/01279-001)
  - for 2-modules: box (9155015, 01285-001), frame (9155012/9155012B, 01280-001/01281-001)
  - for 3-modules: box (9155016, 01286-001), frame(9155013/9155013B, 01282-001/01283-001)

To install a device **2N Access Unit 2.0** into a wall, mount the flush mounting box first. Then install the device into it.

### 2-Module Installation

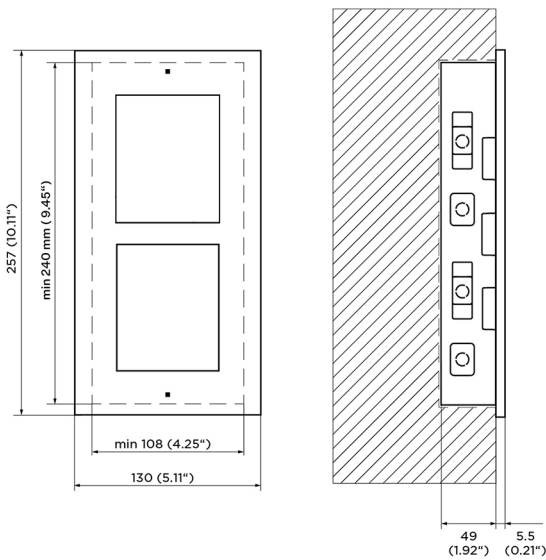

### Box Installation

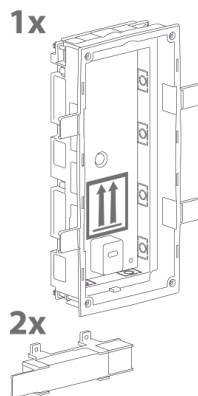

1.

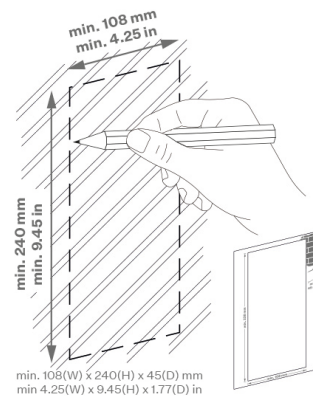

## Installation

2.

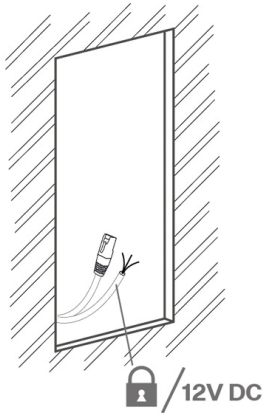

3.

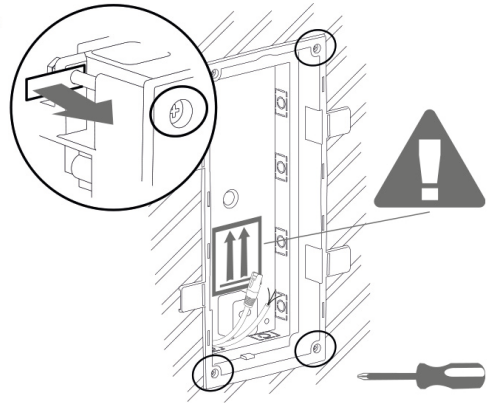

4.

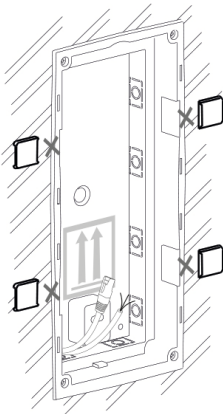

5.

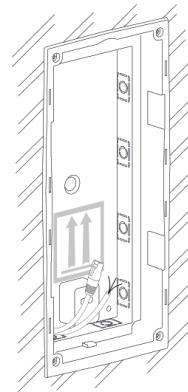

### WARNING

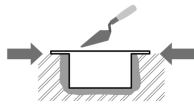

Make sure that the flush mounting box edges are not aligned with the wall but overlap the wall surface. When the proper box installation instructions are not met, water might get in and destroy the device installed. Side stops are used for a correct wall position.



### CAUTION

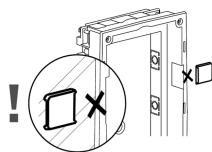

When the walling material has hardened, break off the side stops.

### 2-Module Installation into Box

1.

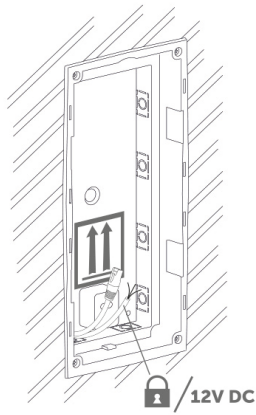

2.

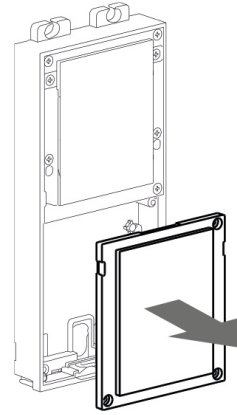

3.

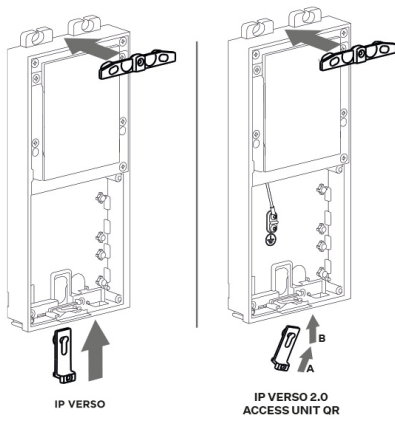

4.

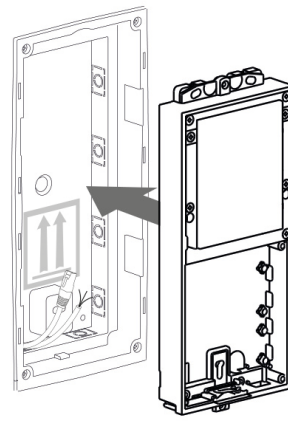

5.

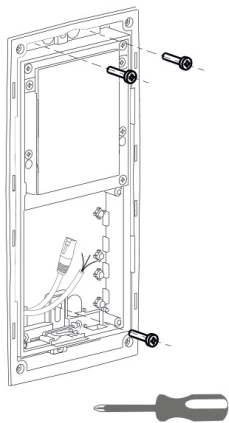

6.

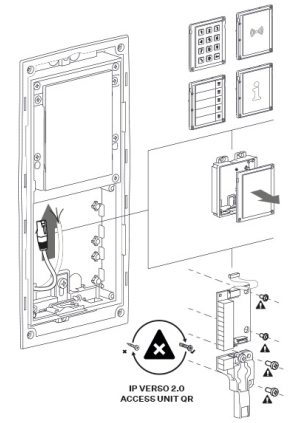

## Installation

7.

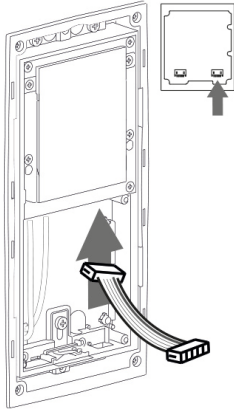

8.

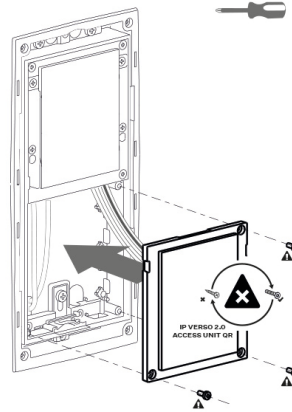

9.

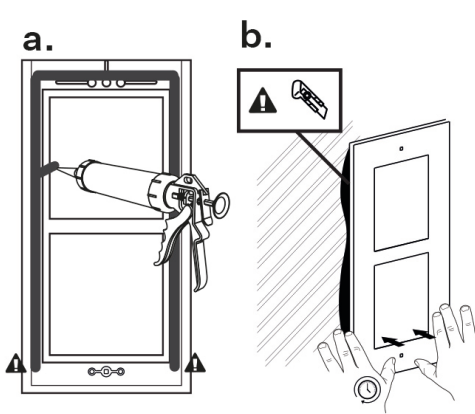

10.

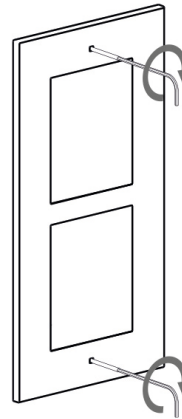

### Frame Attachment

Check the frame sealing before fitting the frame.

Screw the flush mounting frame in the upper and bottom parts.

Hang the surface mounting frame on the hook in the upper part and then screw it tight in the bottom part.

### Installation of Multiple 2-Module Boxes Next to Each Other

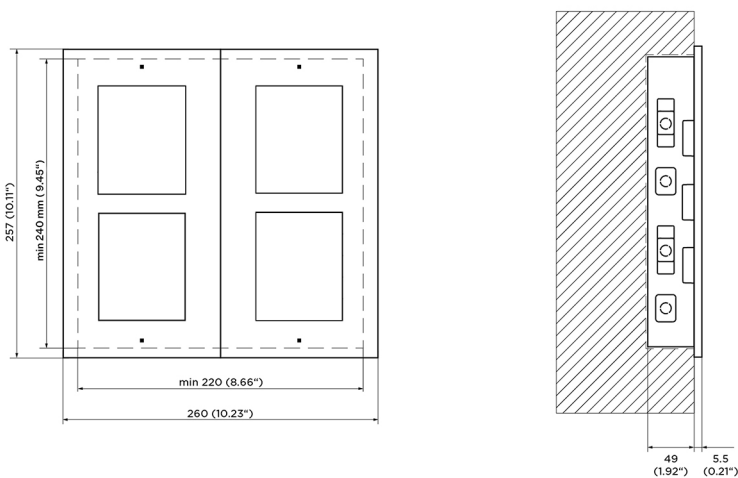

# Installation

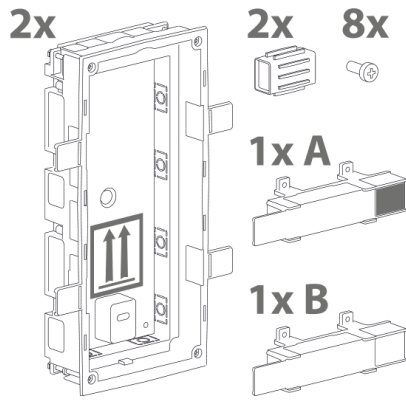

**1.**

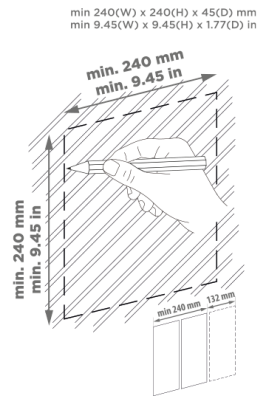

**2.**

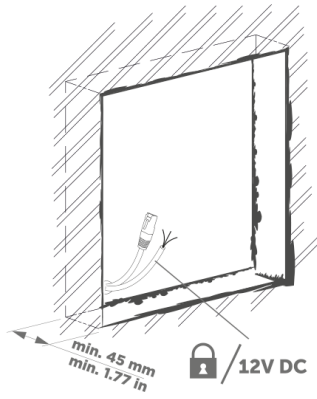

**3.**

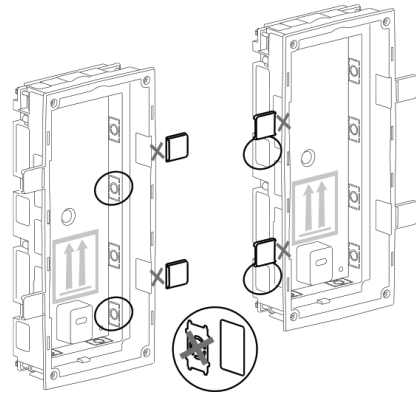

**4.**

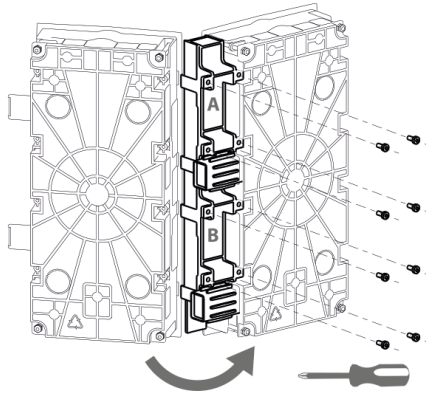

**5.**

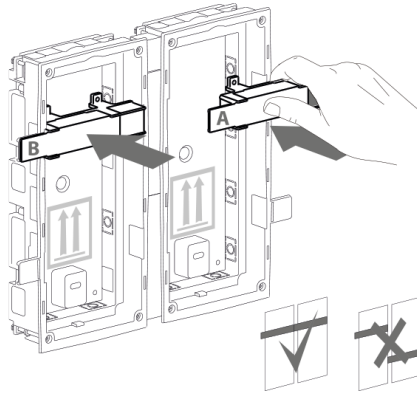

**6.**

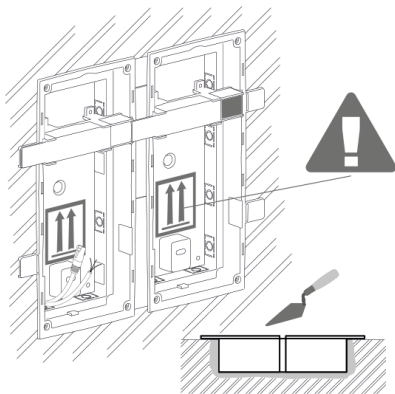

**7.**

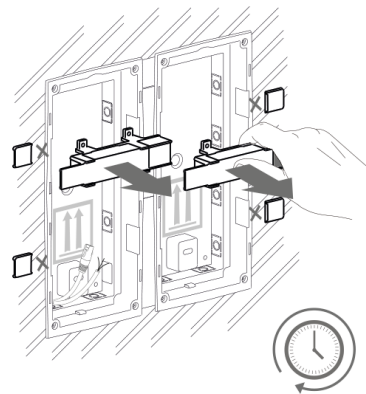



**WARNING**

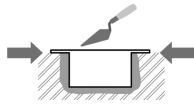

Make sure that the flush mounting box edges are not aligned with the wall but overlap the wall surface. When the proper box installation instructions are not met, water might get in and destroy the device installed. Side stops are used for a correct wall position.



**CAUTION**

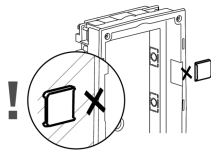

When the walling material has hardened, break off the side stops.

**Installation of Multiple 2-Modules into Box**

1.

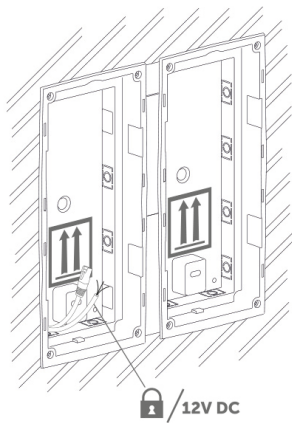

2.

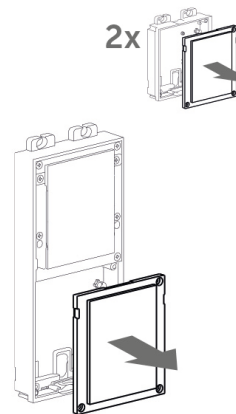

3.

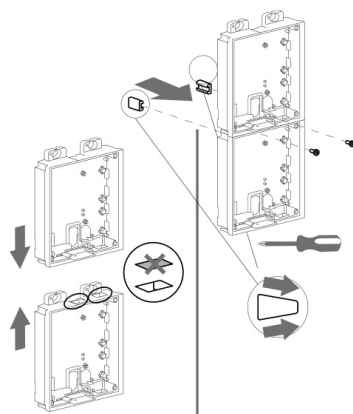

4.

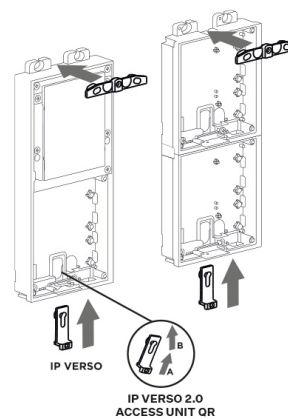

# Installation

5.



6.

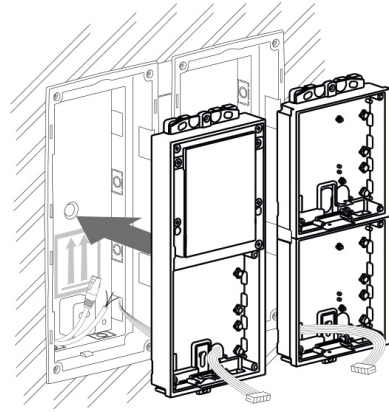

7.

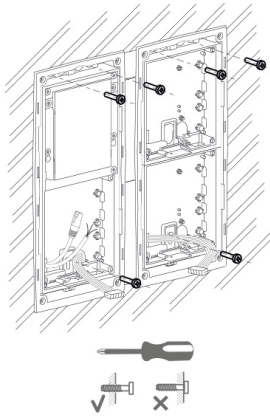

8.

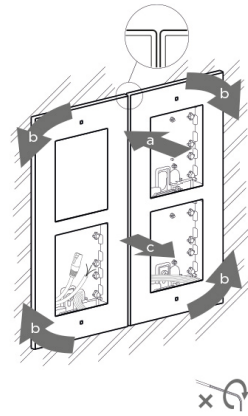

9.

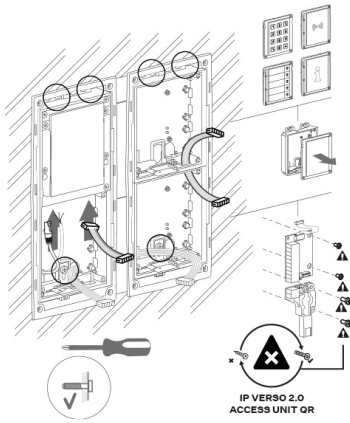

10.

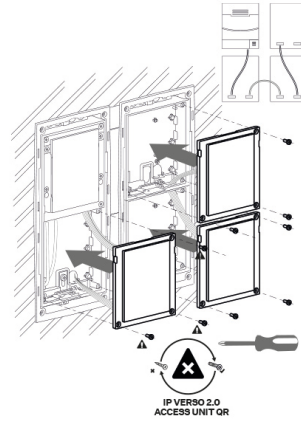

11.

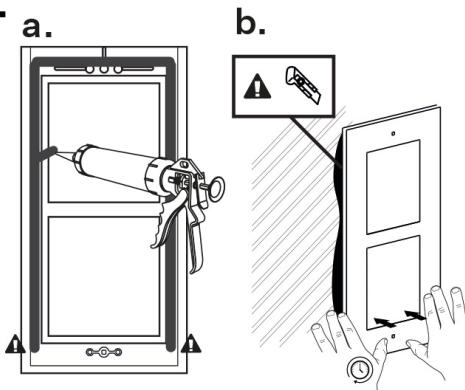

12.

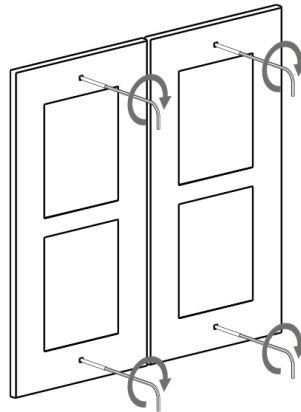

### 3-Module Installation

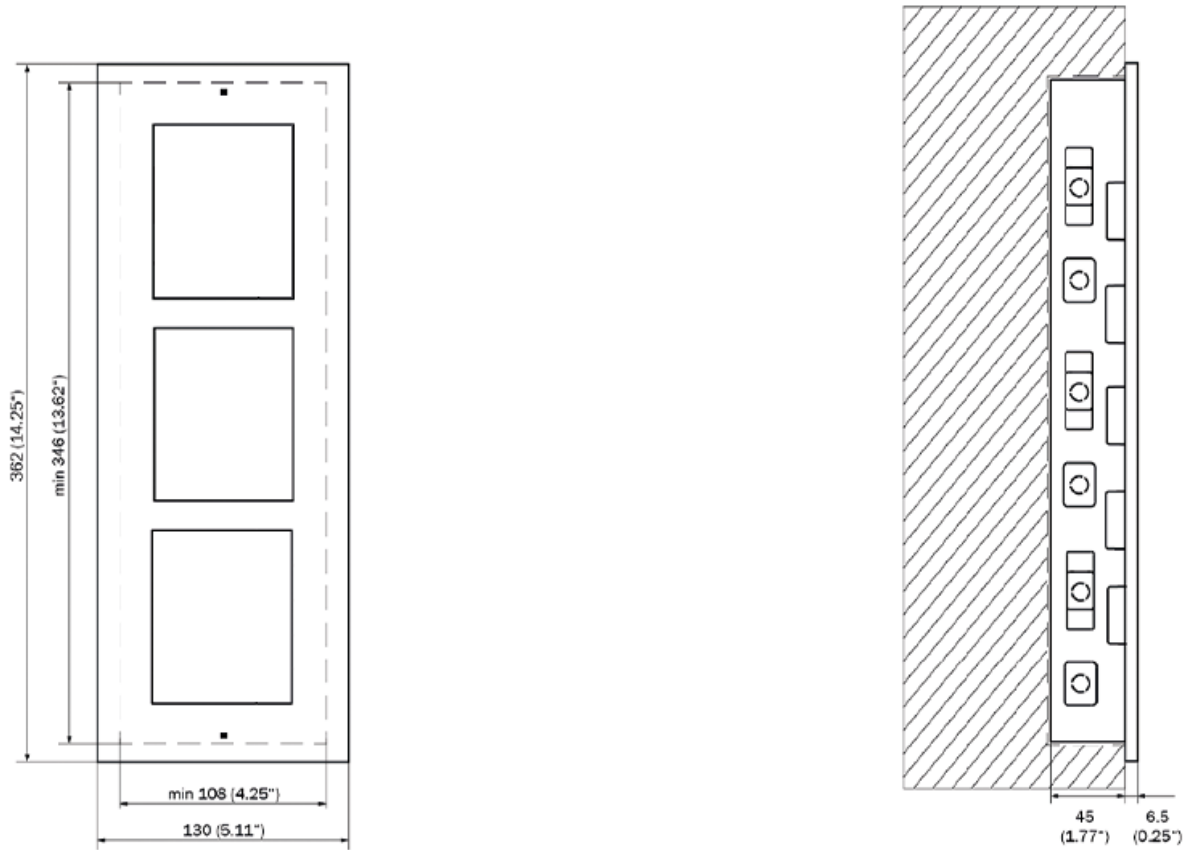

### Box Installation

1x

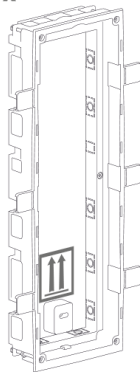

1.

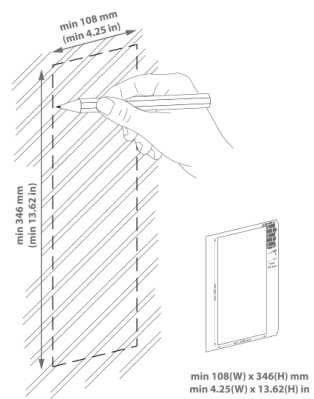

## Installation

2.

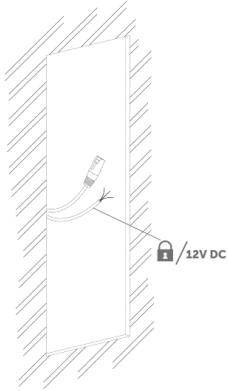

3.

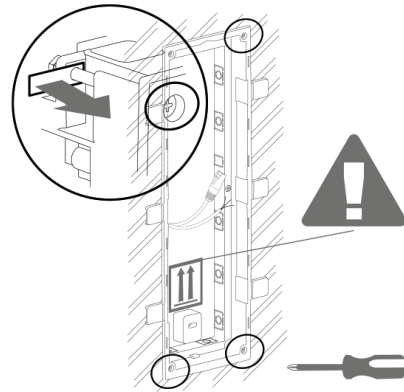

4.

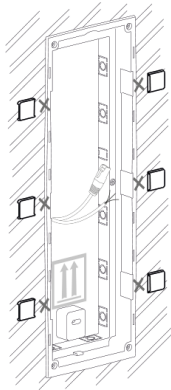

5.

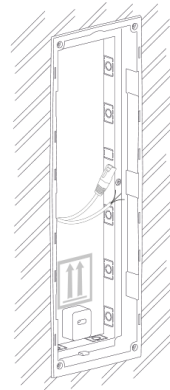

### WARNING

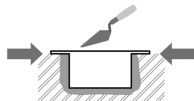

Make sure that the flush mounting box edges are not aligned with the wall but overlap the wall surface. When the proper box installation instructions are not met, water might get in and destroy the device installed. Side stops are used for a correct wall position.



### CAUTION

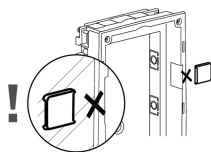

When the walling material has hardened, break off the side stops.

### 3-Module Installation into Box

1.

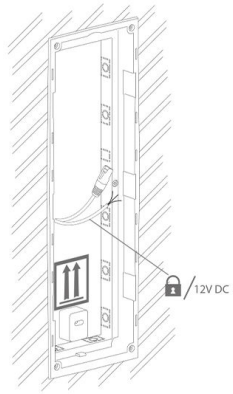

2.

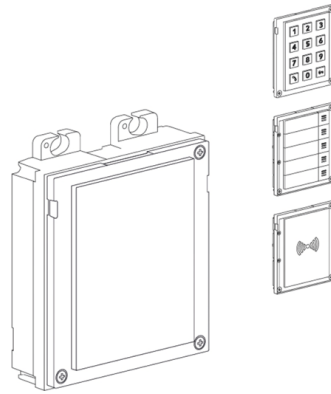

3.

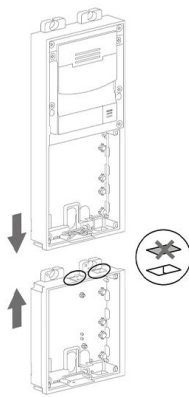

4.

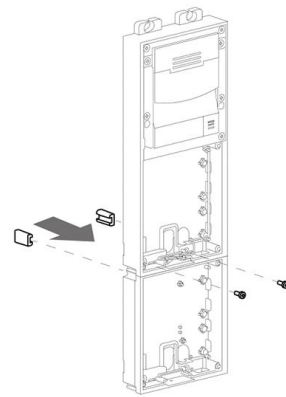

5.

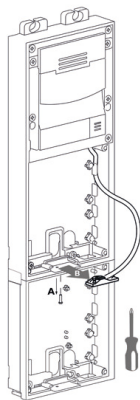

6.

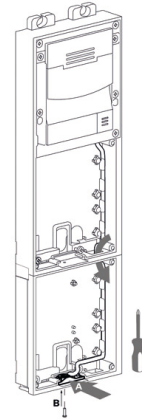

## Installation

7.

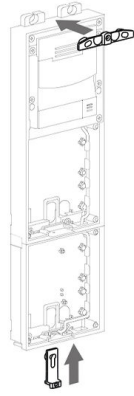

8.

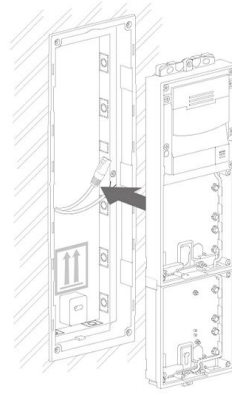

9.

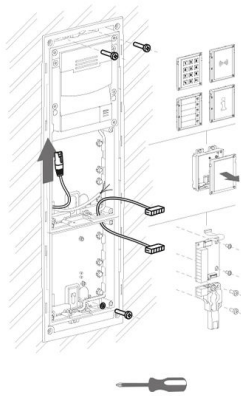

10.

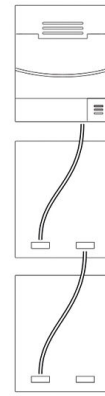

11.

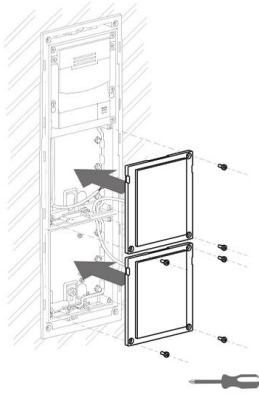

12.



### Frame Attachment

Check the frame sealing before fitting the frame.

Screw the flush mounting frame in the upper and bottom parts.

Hang the surface mounting frame on the hook in the upper part and then screw it tight in the bottom part.

### 1-Module Installation

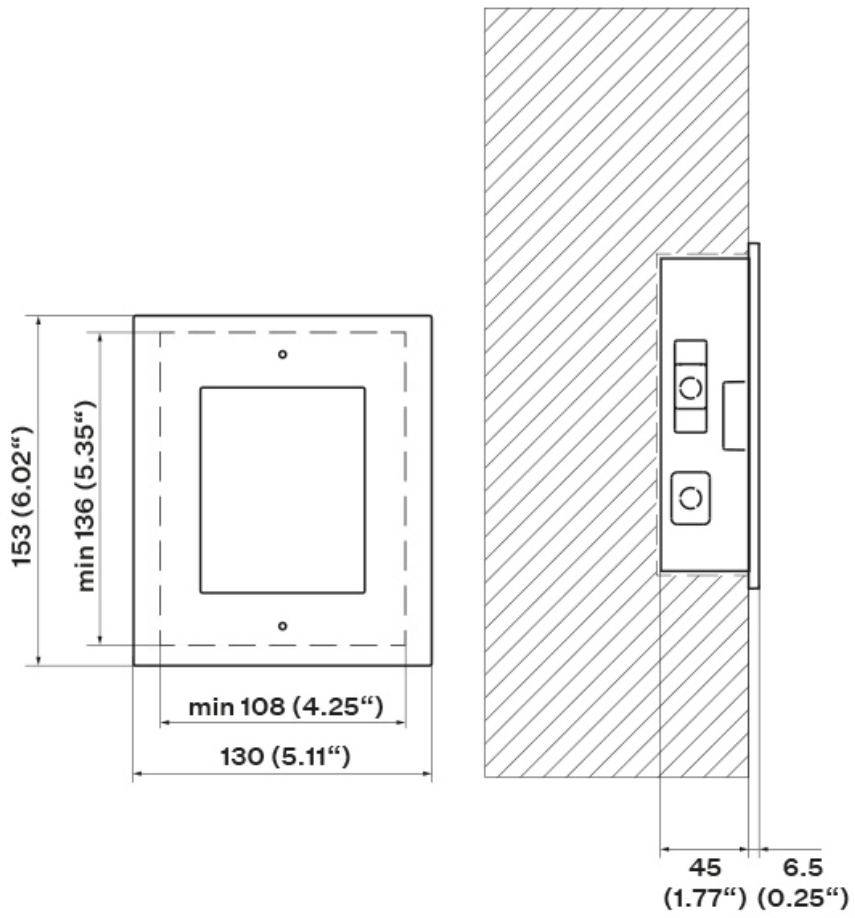

### Box Installation

1x

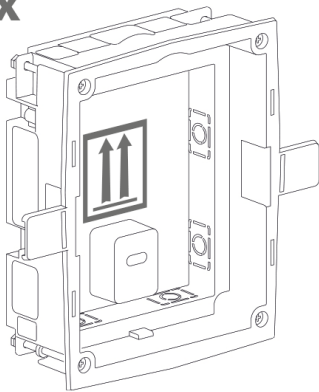

1.

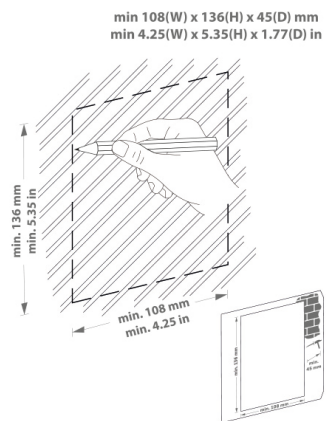

## Installation

2.

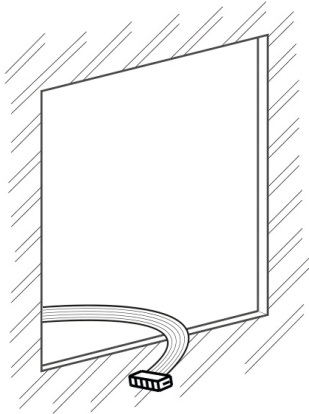

3.

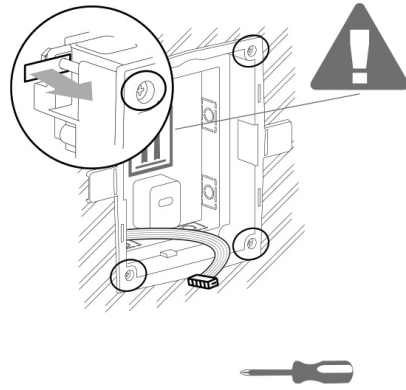

4.

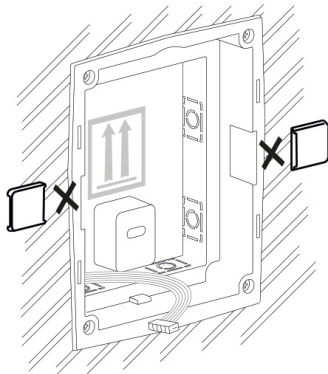

5.

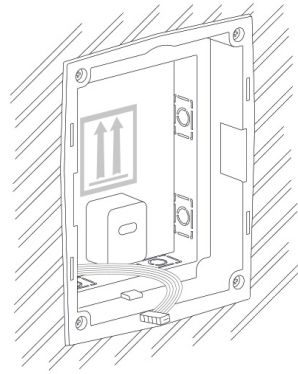

### WARNING

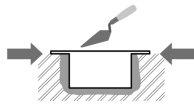

Make sure that the flush mounting box edges are not aligned with the wall but overlap the wall surface. When the proper box installation instructions are not met, water might get in and destroy the device installed. Side stops are used for a correct wall position.



### CAUTION

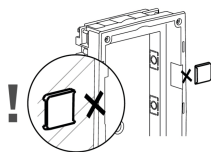

When the walling material has hardened, break off the side stops.

### 1-Module Installation into Box

1.

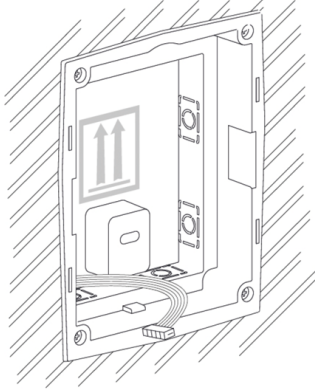

2.

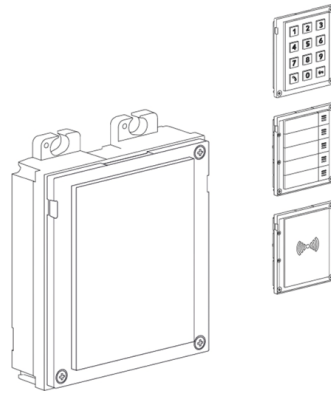

3.

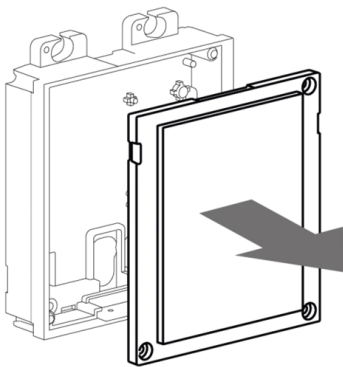

4.

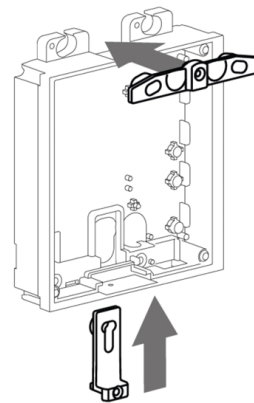

5.

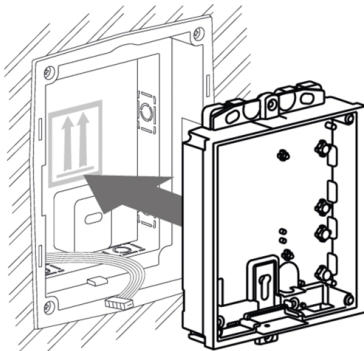

6.

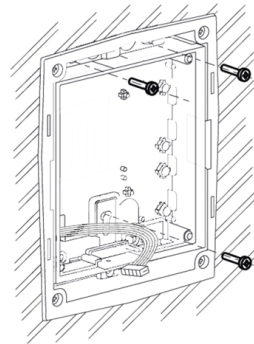

7.

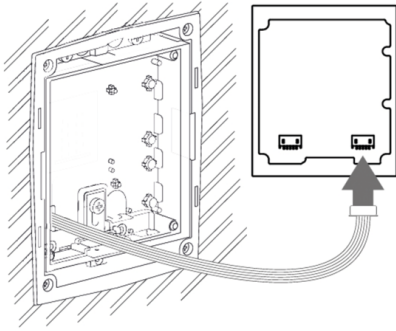

8.

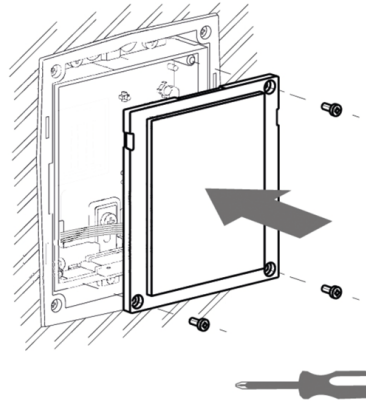

9.

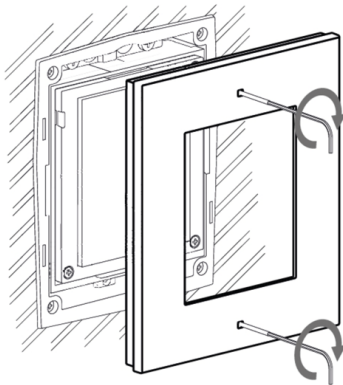

10.

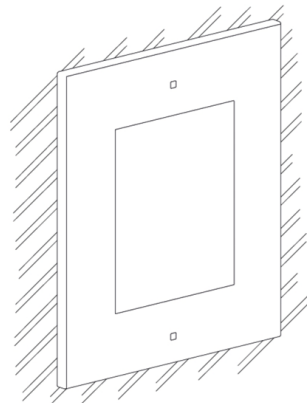

### Frame Attachment

Check the frame sealing before fitting the frame.

Screw the flush mounting frame in the upper and bottom parts.

Hang the surface mounting frame on the hook in the upper part and then screw it tight in the bottom part.

### Surface Installation

What you need for mounting:

- **2N Access Unit 2.0**
- drilling template
- a proper frame
  - for 1-modules: frame (9155021/9155021B, 01287-001/01288-001)
  - for 2-modules: frame (9155022/9155022B, 01289-001/01290-001)
  - for 3-modules: frame (9155023/9155023B, 01291-001/01292-001)



#### NOTE

The one-module frame is designed for stand-alone installations of extending modules such as OUT readers, etc. A 2-module frame is required for the main unit installation.

For uneven surfaces, use a backplate for the required count of modules (9155061/9155062, 01293-001/01294-001).



**DANGER**

Eliminate the risk of personal injury! Surface installation is not recommended for narrow passages or places where people's attention is distracted by something else. The manufacturer shall not be liable for injuries in such cases!



**WARNING**

- Make sure that the installation surface is flat with a maximum inequality of 0.5 mm. (e.g. prefabricated boards, glass, cut stone, etc.). If the installation surface is not even, use the flush mounting type or equalize the wall surface with a backplate (9155061/9155062/9155068, 01293-001/01294-001/01305-001) or make the wall surface perfectly flat.

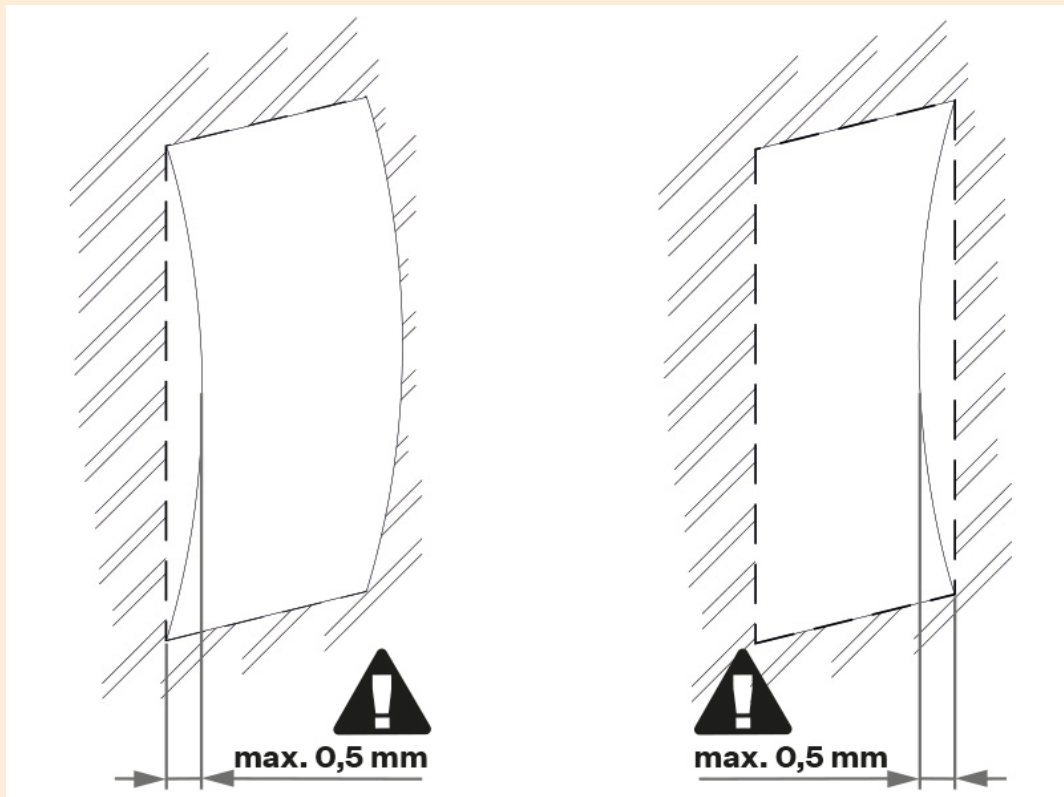

- Surface mounting always poses a problem where the installation is exposed to potential vandalism (such as public garages, etc.). In that case, use steel fixing elements instead of the dowels and screws included in the delivery.

### 1-Module Installation

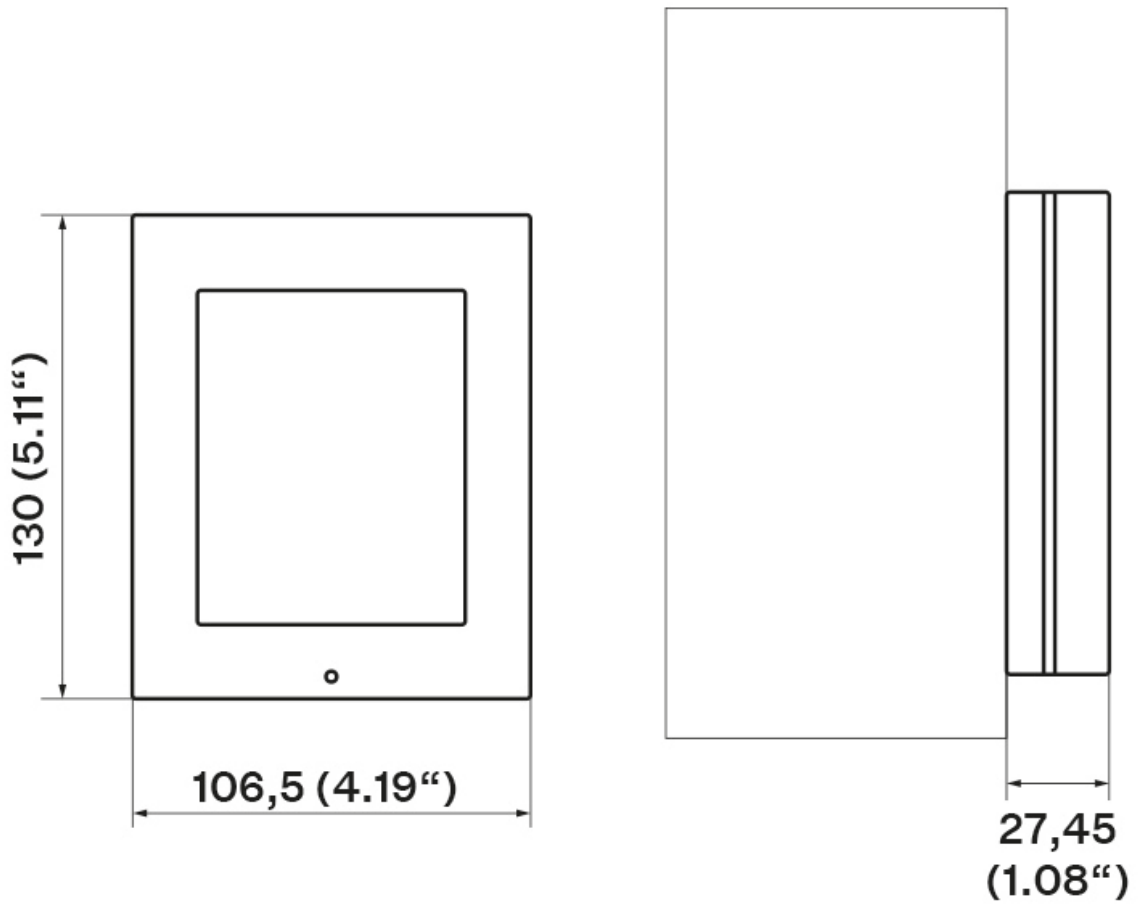

**TIP**  
Download the [drilling template](#) from 2N.com.

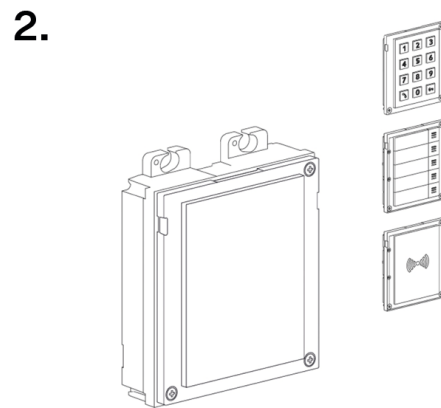
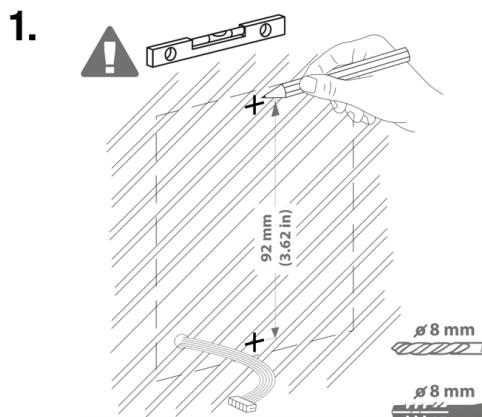

# Installation

3.

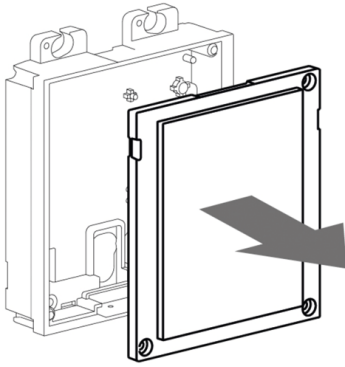

4.

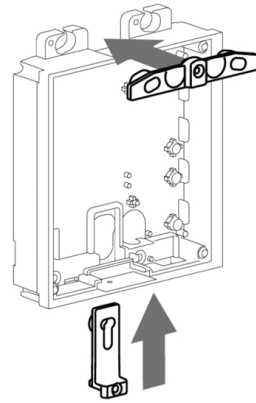

5.

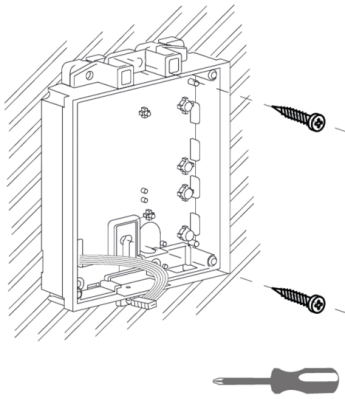

6.

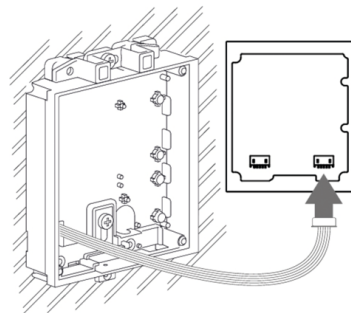

7.

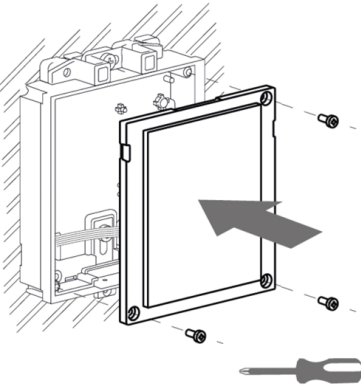

8.

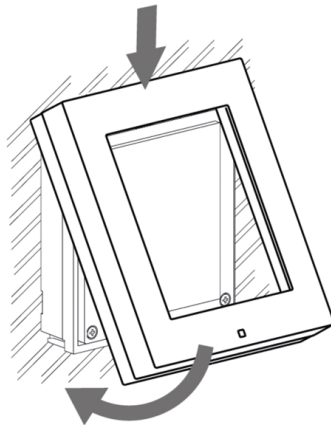

9.

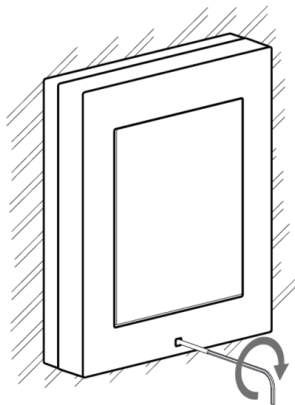

10.

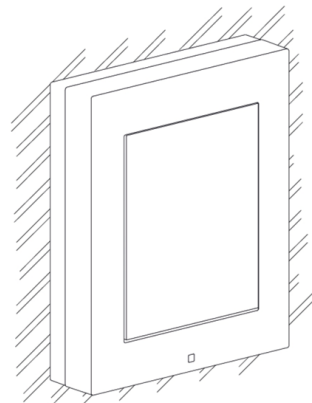

### Frame Attachment

Check the frame sealing before fitting the frame.

Screw the flush mounting frame in the upper and bottom parts.

Hang the surface mounting frame on the hook in the upper part and then screw it tight in the bottom part.

### 2-Module Installation

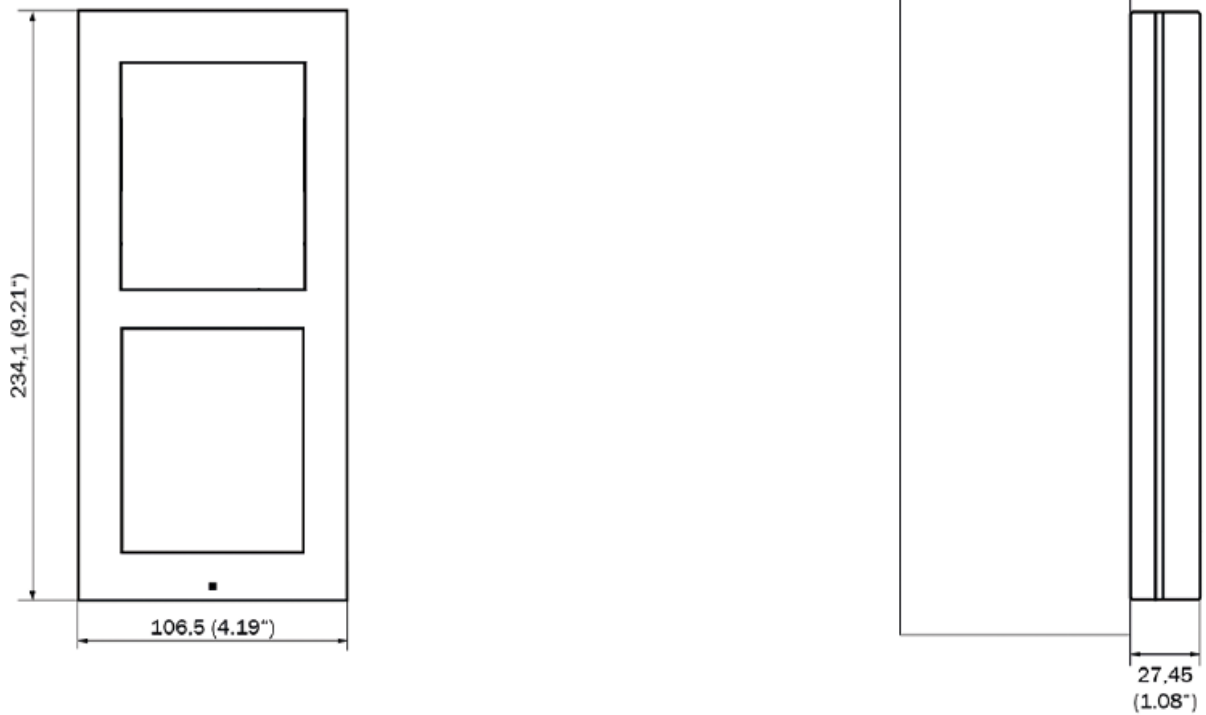

**TIP**

Download the [drilling template](#) from 2N.com.

# Installation

1.

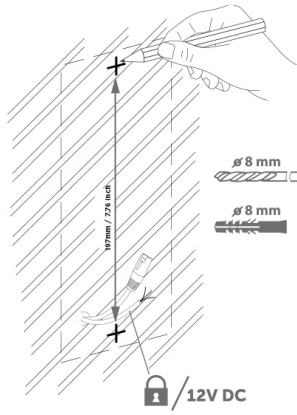

2.

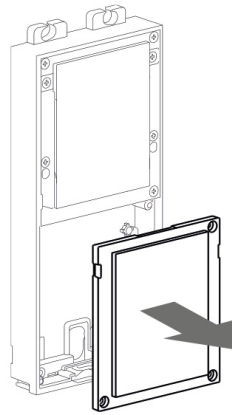

3.

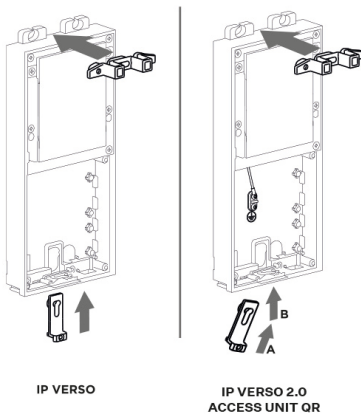

4.

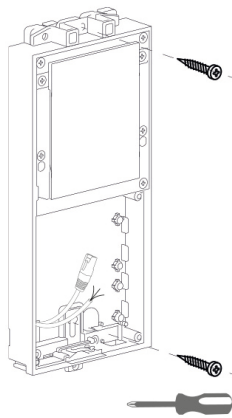

5.

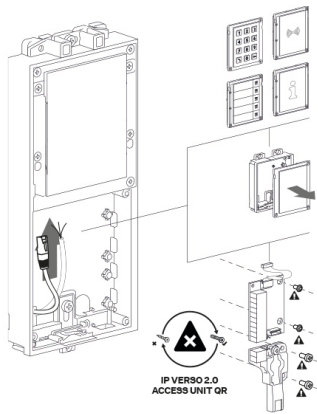

6.

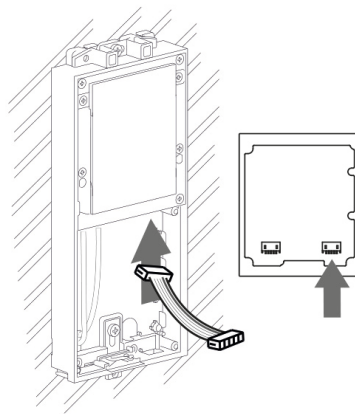

7.

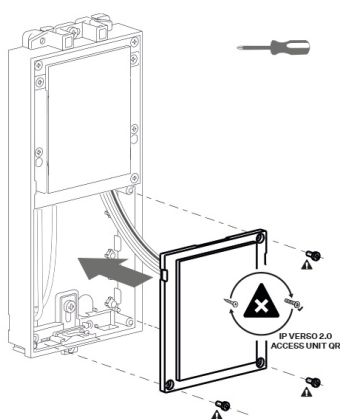

8.

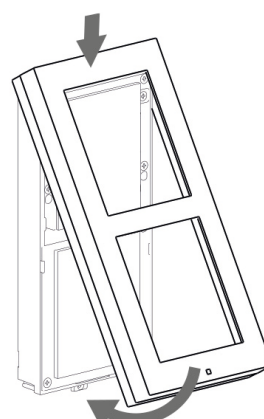

9.

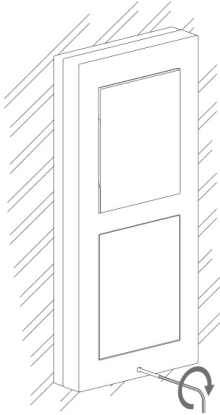

10.

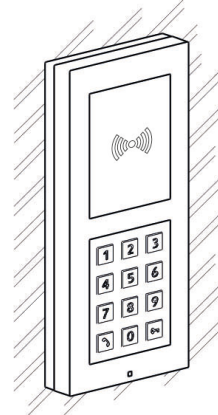

### Frame Attachment

Check the frame sealing before fitting the frame.

Screw the flush mounting frame in the upper and bottom parts.

Hang the surface mounting frame on the hook in the upper part and then screw it tight in the bottom part.

### Installation of Multiple 2-Modules Next to Each Other

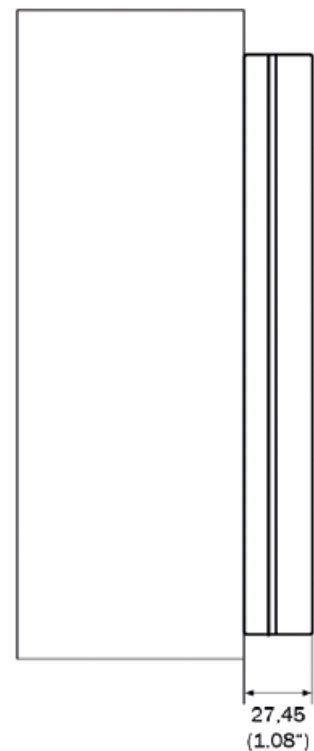
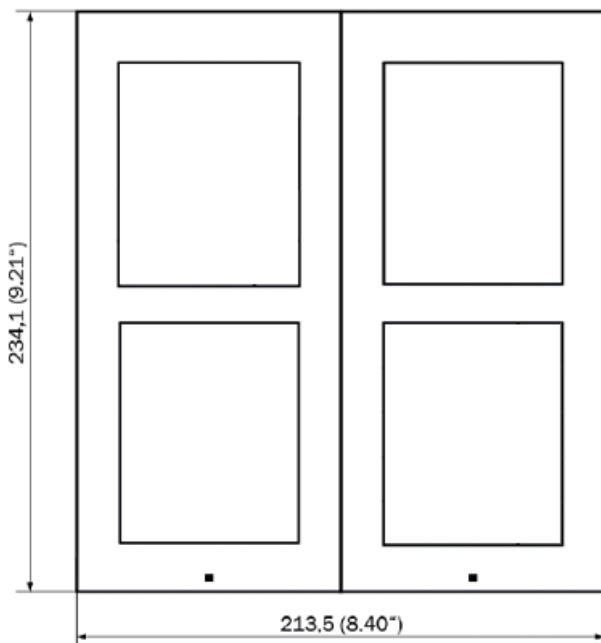

# Installation

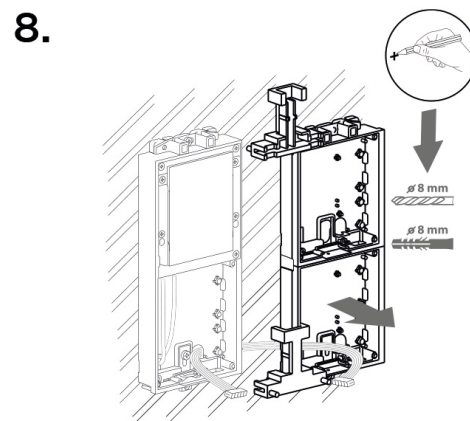
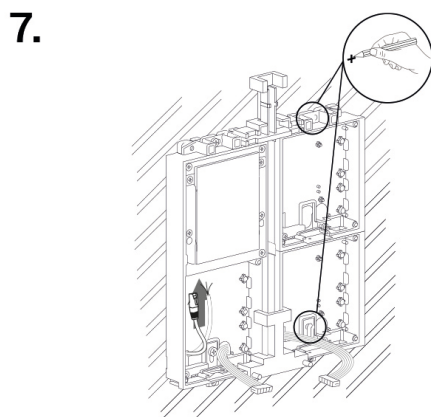
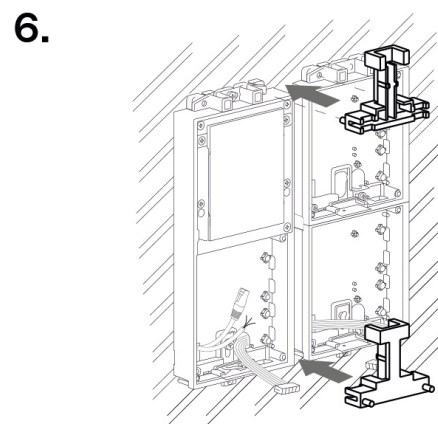
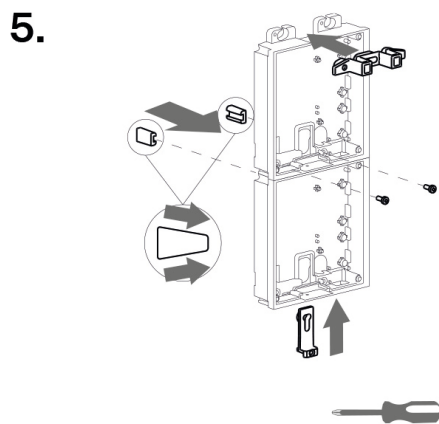
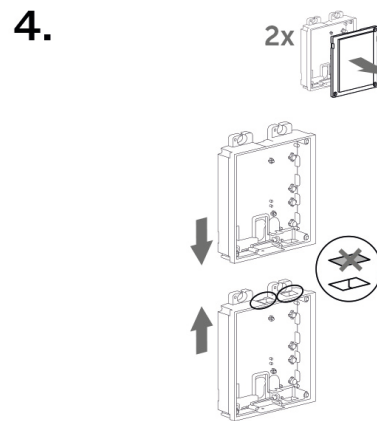
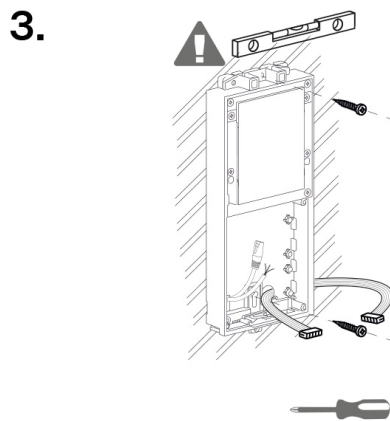
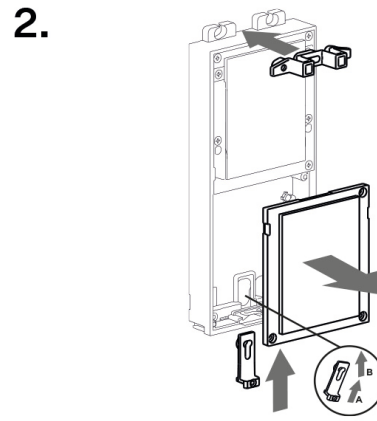
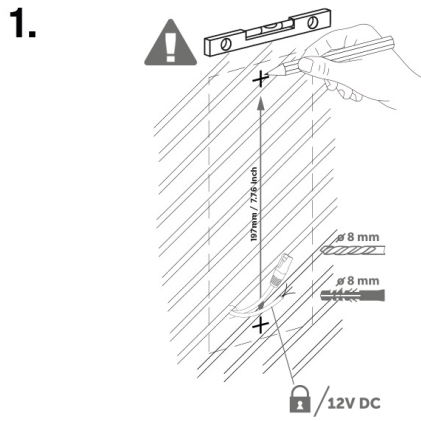

9.

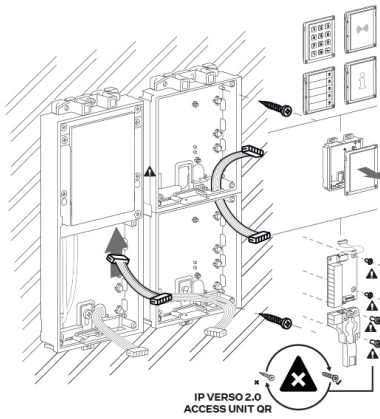

10.

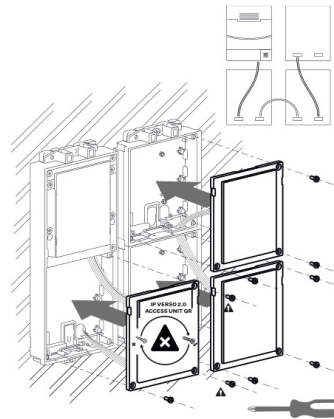

11.

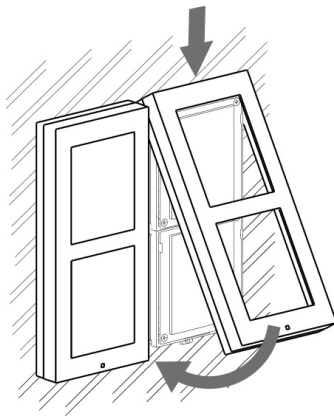

12.

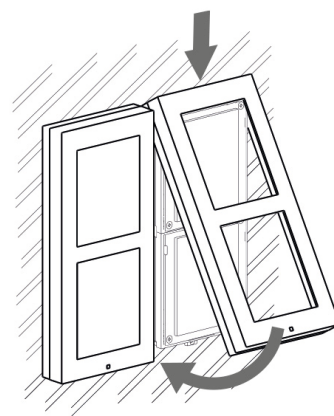

### Frame Attachment

Check the frame sealing before fitting the frame.

Screw the flush mounting frame in the upper and bottom parts.

Hang the surface mounting frame on the hook in the upper part and then screw it tight in the bottom part.

### 3-Module Installation

To install a 3-module, put a 2-module with a 1-module together.

## Installation

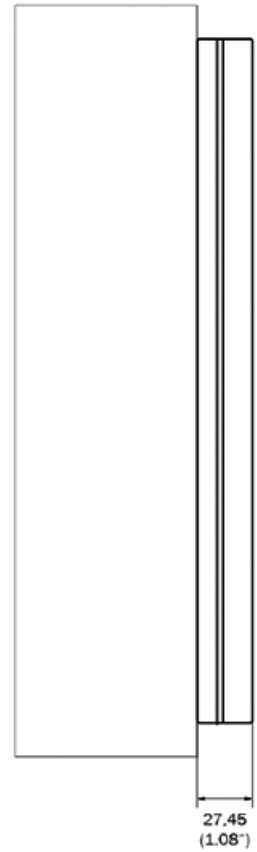
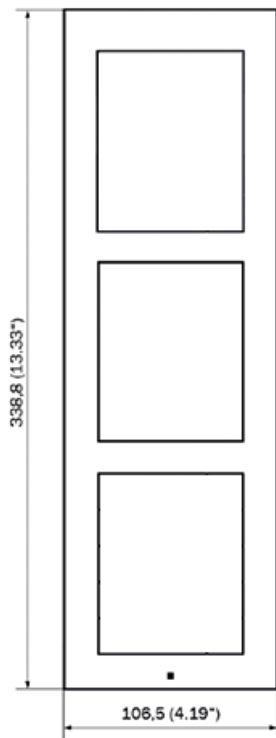

### TIP

Download the [drilling template](#) from 2N.com.

1.

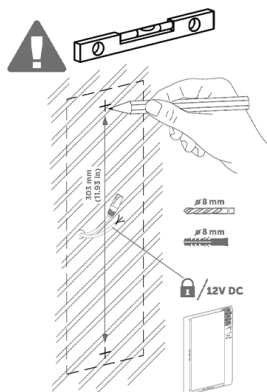

2.

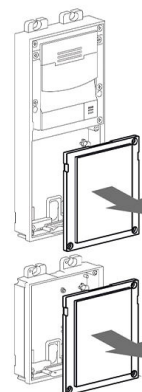

# Installation

3.

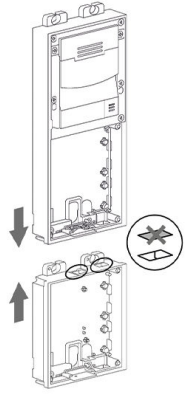

4.

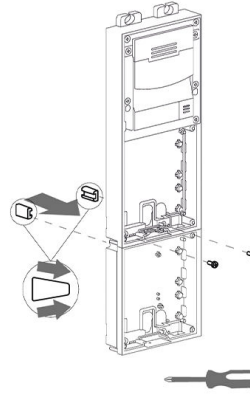

5.

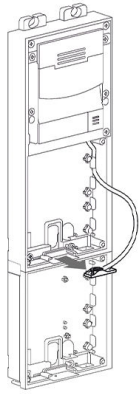

6.

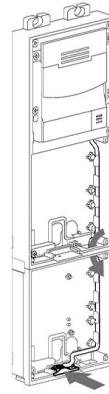

7.

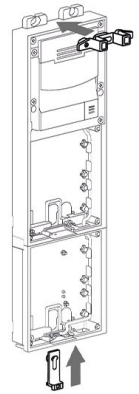

8.

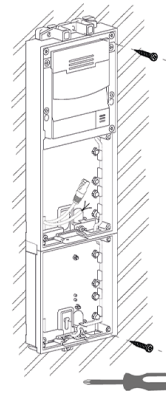

9.

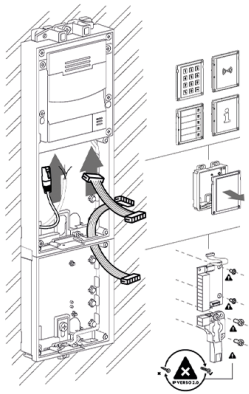

10.

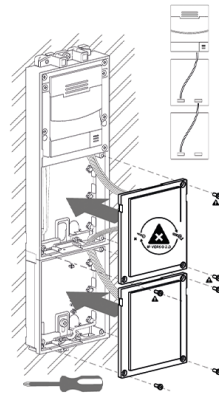

11.

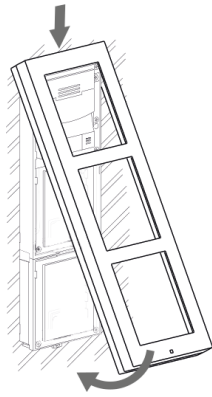

12.



### Frame Attachment

Check the frame sealing before fitting the frame.

Screw the flush mounting frame in the upper and bottom parts.

Hang the surface mounting frame on the hook in the upper part and then screw it tight in the bottom part.

### Installation of Multiple 3-Modules Next to Each Other

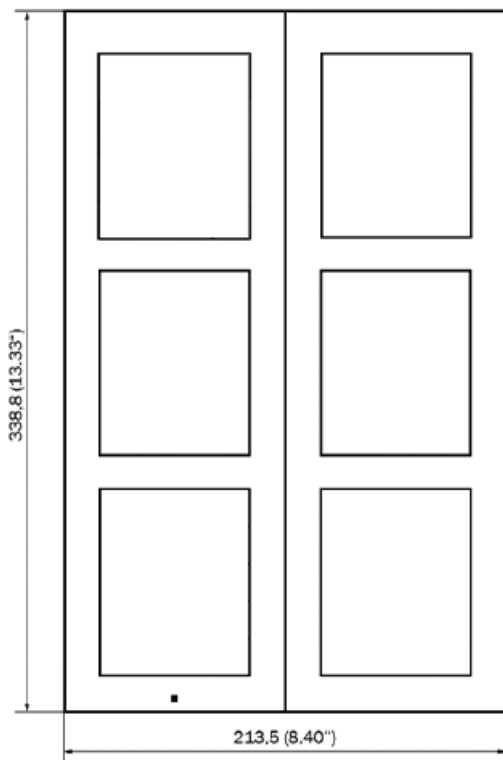

# Installation

1.

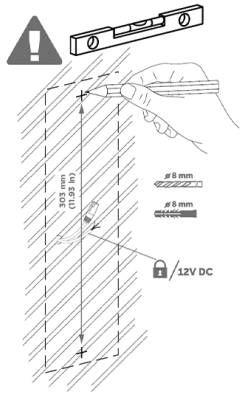

2.

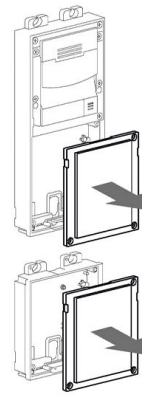

3.

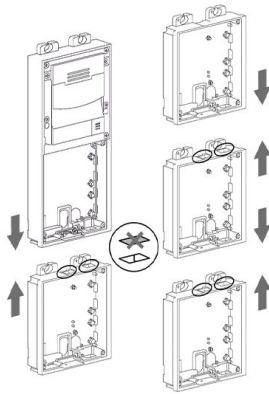

4.

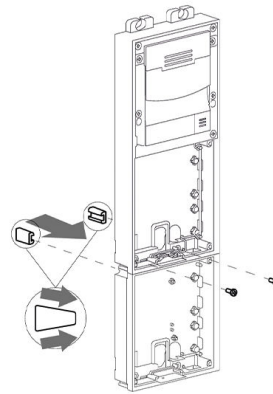

5.

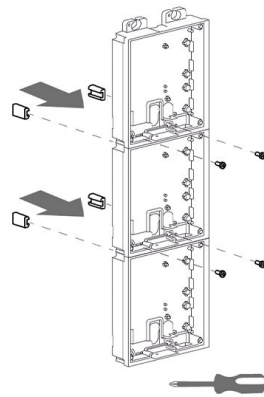

6.

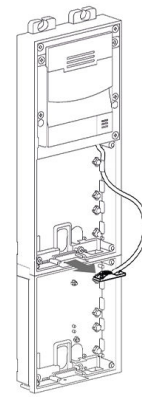

7.

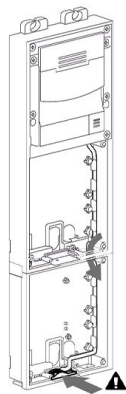

8.

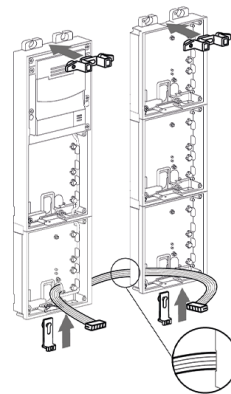

9.

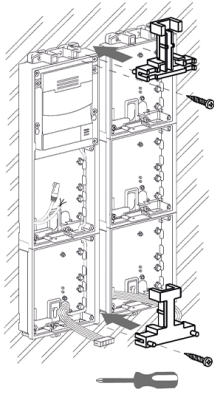

10.

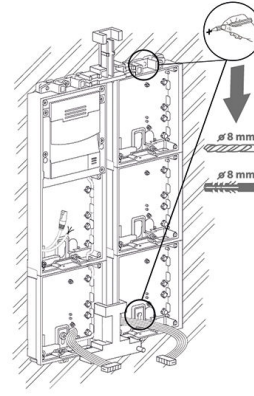

11.

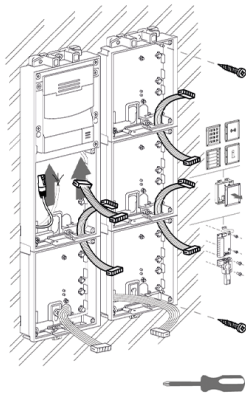

12.

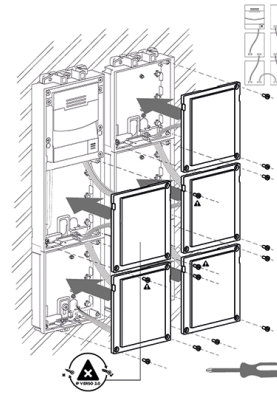

13.

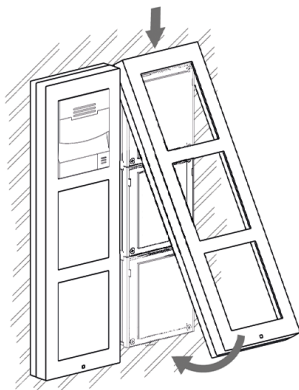

14.



### Frame Attachment

Check the frame sealing before fitting the frame.

Screw the flush mounting frame in the upper and bottom parts.

Hang the surface mounting frame on the hook in the upper part and then screw it tight in the bottom part.

### Backplate Use

For uneven surfaces, use a backplate for the required count of modules (9155061/9155062, 01293-001/01294-001).

On uneven wall

1.

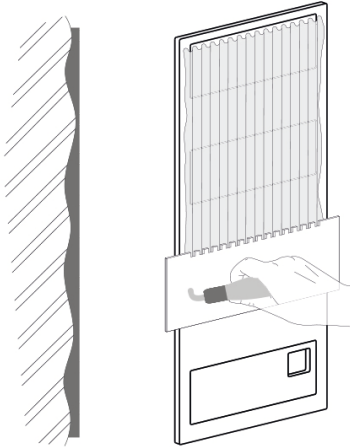

2.

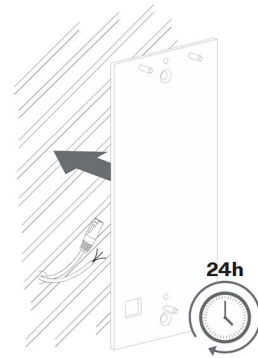

3.

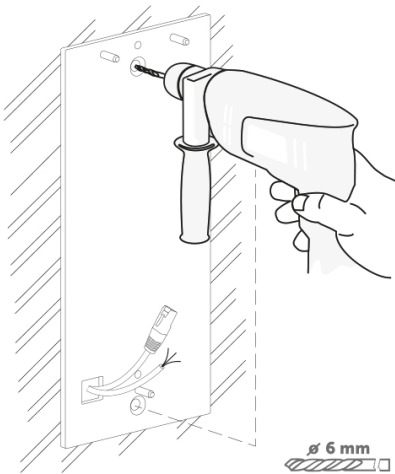

4.

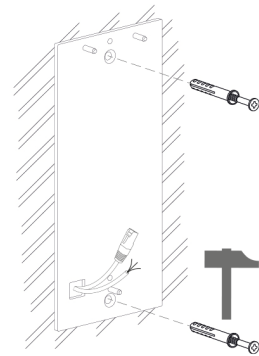

5.

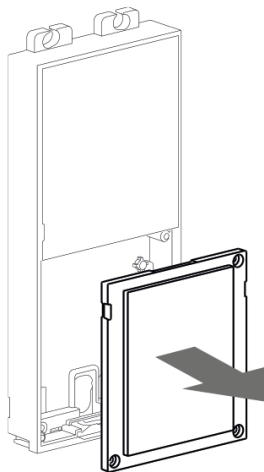

6.

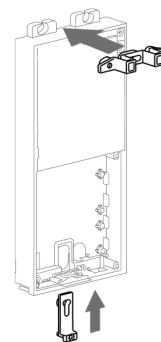

7.

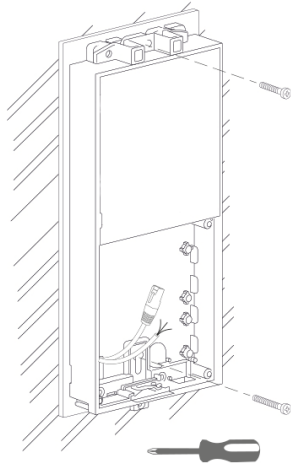

**On glass**

The backplate for uneven surfaces can also be used for installation on glass.

1.

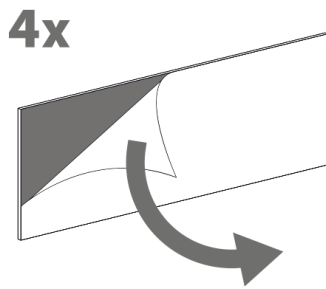

2.

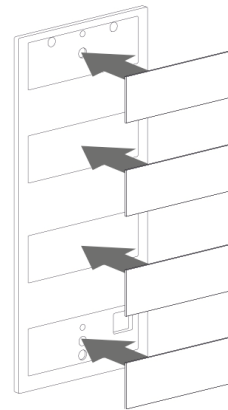

3.

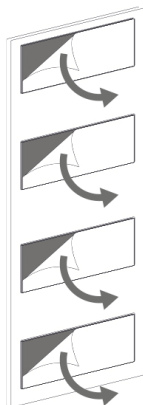

4.

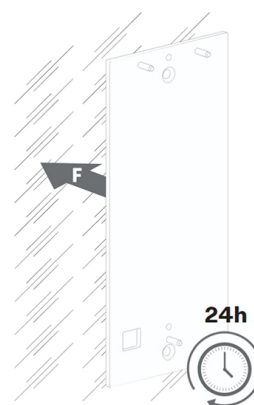

5.

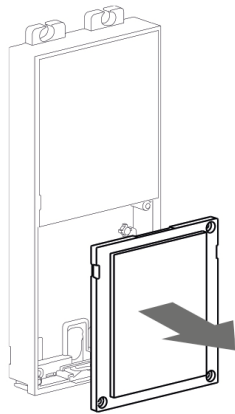

6.

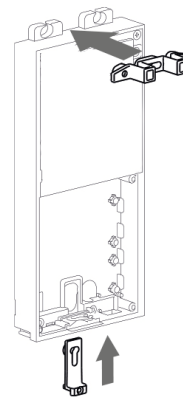

7.

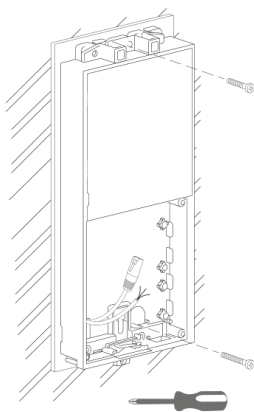

8.

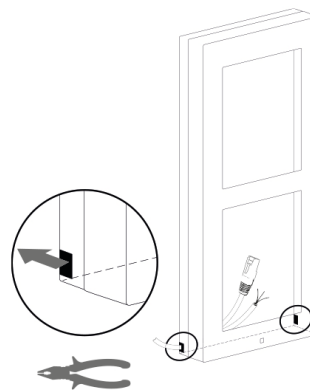

## Electric Installation

### Stand-alone access unit power supply installation

1. Place the **2N Access Unit 2.0** on the flush mounting box / pre-drilled holes with dowels and pull the cables through the bottom holes. Pull the Ethernet cable through the bottom hole to the left if necessary.
2. Insert the metal fitting elements up and down and screw the access unit tight. You can level the unit slightly in this mounting type.



#### CAUTION

It only applies to **2N Access Unit 2.0** that modules can be freely changed within a unit. This does not apply to earlier **2N Access Unit 1.0** versions, where the entire unit has to be replaced.

### Power supply installation for access unit with an extending module

1. Unscrew the upper part of the module - keypad, RFID reader, etc.
2. Use a flat screwdriver to take the upper part out.
3. Slide the extending module to the access unit. Secure its position with small side wedges and screws.
4. Place the assembled modules on the flush mounting box / predrilled holes with dowels and pull the cables through the access unit bottom holes. Feed the Ethernet cable without the connector from the extending module to the access unit if necessary.

**CAUTION**

It only applies to **2N Access Unit 2.0** that modules can be freely changed within a unit. This does not apply to earlier **2N Access Unit 1.0** versions, where the entire unit has to be replaced.

**Power Supply**

**2N Access Unit 2.0** can be fed either directly from the LAN if equipped with PoE 802.3af (Class 0, max. 12,95 W) supporting network elements or from an external 12 V  $\pm 15\%$  / 1 A DC power supply.

**CAUTION**

- The external power supply should comply with PS2/LPS.

**WARNING**

**2N Access Unit 2.0** with HW version 599v4 or lower cannot be fed from an external power supply and PoE at the same time. A combined supply might result in a device damage.

**PoE Supply**

**2N Access Unit 2.0** is compatible with the PoE 802.3af (Class 0, max. 12,95 W) technology (Class 0, max. 12,95 W) and can be supplied directly from the LAN via compatible network elements. If your LAN does not support this technology, insert a PoE injector, between **2N Access Unit 2.0** and the nearest network element. This power supply provides **2N Access Unit 2.0** with 12 W for its own feeding and for connected modules.

**External Power Supply**

Use a SELV supply 12 V  $\pm 15\%$  dimensioned to the current consumption according to the required power output for the to make your device work reliably.

**CAUTION**

Make sure that the wires are firmly attached to the terminal to avoid any free contact.

**Adapter Connection (1341481, 02520-001)**

The white wire at the end of the adapter carries the positive charge (+), the black wire carries the negative charge (-).

**Combined Power Supply**

**2N Access Unit 2.0** can be fed from an external power supply and PoE at the same time. In this configuration, the maximum power for the connected modules is available.

## Combined Power Supply

### Cabling Description

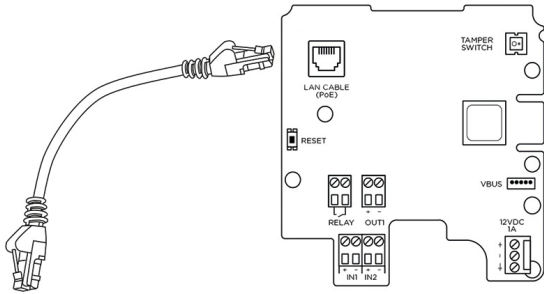

UTP cable connection to board **2N Access Unit 2.0**

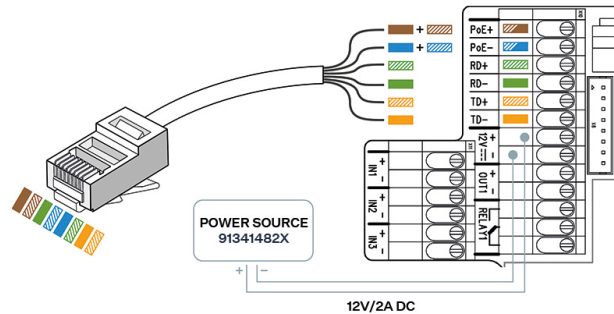

UTP cable connection to terminal board **2N Access Unit**

Legend to figure	Component	Description
RELAY	RELAY	<p>The relay terminal properties are different for different board versions.</p> <p><b>PCB board version 599v6 and higher:</b></p> <ul style="list-style-type: none"> <li>RELAY1 terminals with accessible 30 V / 1 A AC/DC NO contact.</li> </ul> <p><b>PCB board version 599v3 and 599v4:</b></p> <ul style="list-style-type: none"> <li>RELAY1 terminals with accessible 30 V / 1 A AC/DC NO/NC contact. Used for connection of non-critical devices only (lights, e.g.).</li> </ul> <p><b>PCB board version 586v2 and higher:</b></p> <ul style="list-style-type: none"> <li>RELAY1 terminals with accessible 30 V / 1 A AC/DC NO/NC contact. Used for connection of non-critical devices only (lights, e.g.).</li> </ul>
IN1/2/3	Input 1/2/3	<p>The IN1, IN2 and IN3 terminals (IN3 available in 2N Access Unit 1.0 models only) are used as inputs in the passive/active mode (–30 V to +30 V DC) for the Departure button, open door sensor, ESS etc. connection.</p> <ul style="list-style-type: none"> <li>OFF = open contact OR <math>U_{IN} &gt; 1.5 \text{ V}</math></li> <li>ON = closed contact OR <math>U_{IN} &lt; 1.5 \text{ V}</math></li> </ul>
PoE+/-, RD+/-, TD+/-	PoE, RD, TD	LAN terminals (PoE according to 802.1af).

Legend to figure	Component	Description
OUT1	OUT1	OUT1 terminals of the active output for the connection <b>of the Security Relay</b> or an electric lock: 8 to 12 V DC according to power supply (PoE: 10 V; adapter: power supply voltage minus 2 V), up to 600 mA.
12V	12 V / 1 A	External supply terminals <b>2N Access Unit 2.0</b> – 12 V / 1 A.
LAN CABLE (PoE)	RJ-45	RJ-45 adapter connector – no need to use the PoE, RD and TD terminals for this connector.
RESET	RESET	RESET / FACTORY RESET button.



**WARNING**

If a coil containing device is connected, e.g. relays/electromagnetic locks, it is necessary to protect the device output against voltage peak while switching off the induction load. For this way of protection we recommend a 1 A / 1000 V diode (e.g., 1N4007, 1N5407, 1N5408) connected antiparallel to the device.

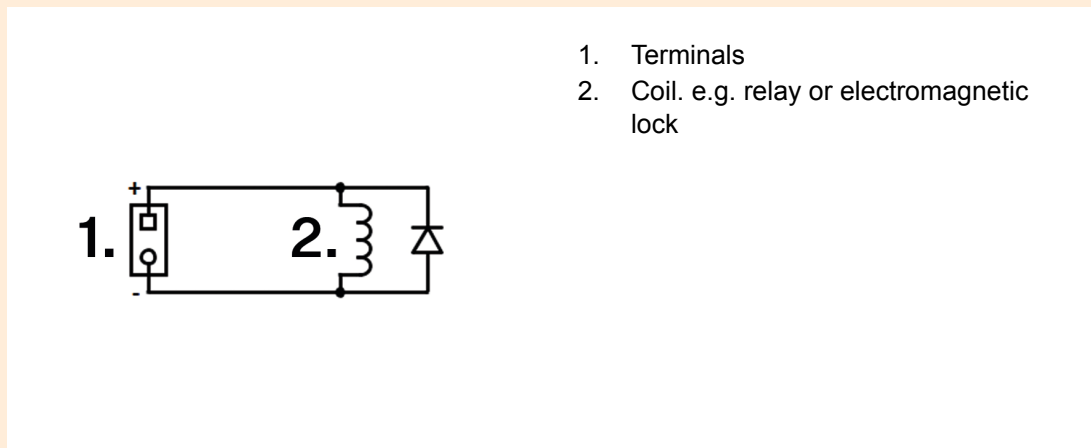

1. Terminals
2. Coil. e.g. relay or electromagnetic lock

**Relay Terminal Wiring Diagrams**

It is possible to connect a device to the **2N Access Unit 2.0** relay terminals to be controlled by this relay, e.g. an electric/electromechanical door lock.

The elements are designated as follows in the diagrams below:

1. Device relay
2. Controlled device

**Wiring diagram for the relay terminal output for switching the electric circuit of the controlled device from PCB board version 599v6**

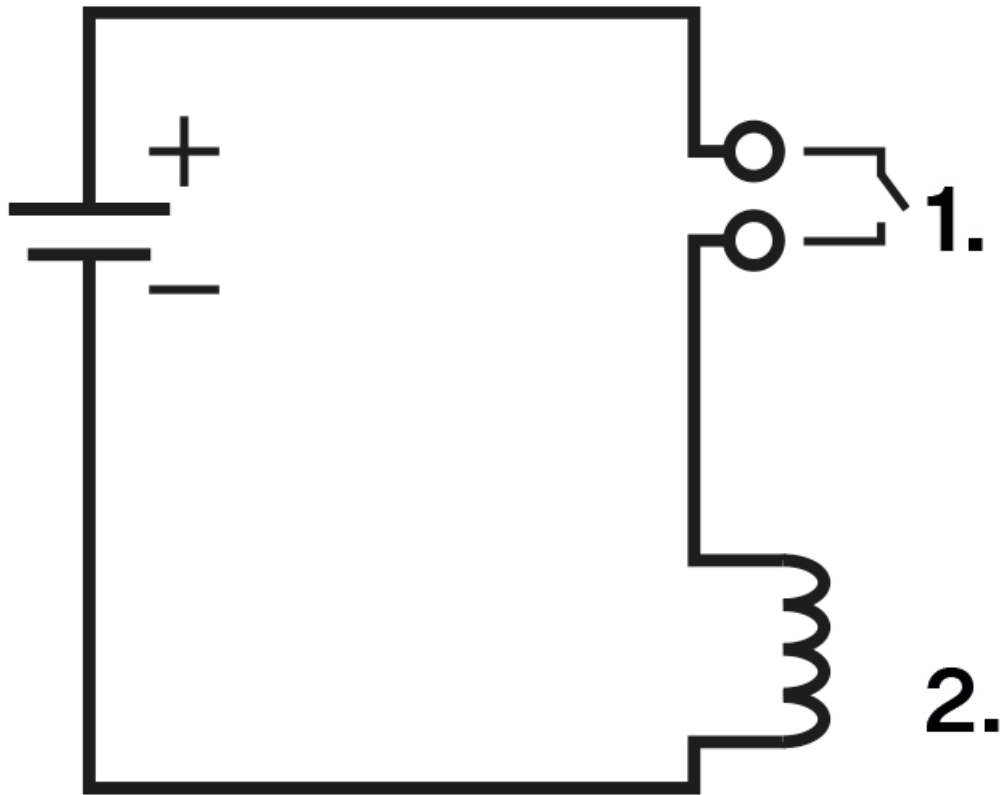

**Wiring diagram for closing the electric circuit of the controlled device from PCB board version 586v2**

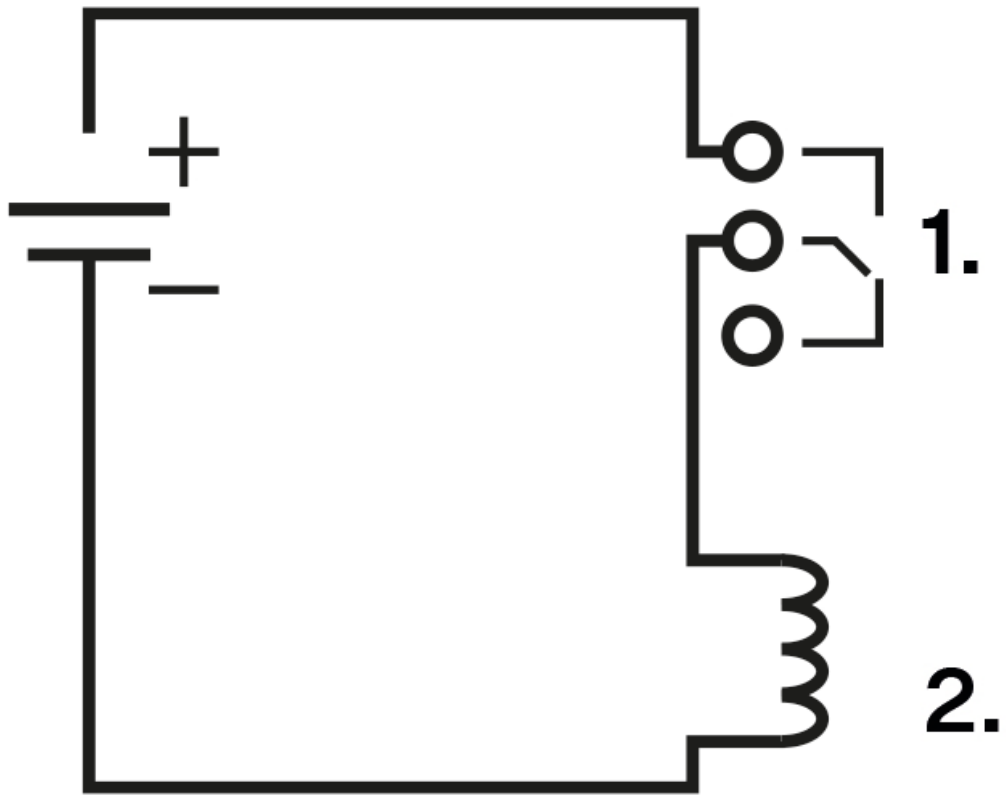

**Wiring diagram for opening the electric circuit of the controlled device from PCB board version 586v2**

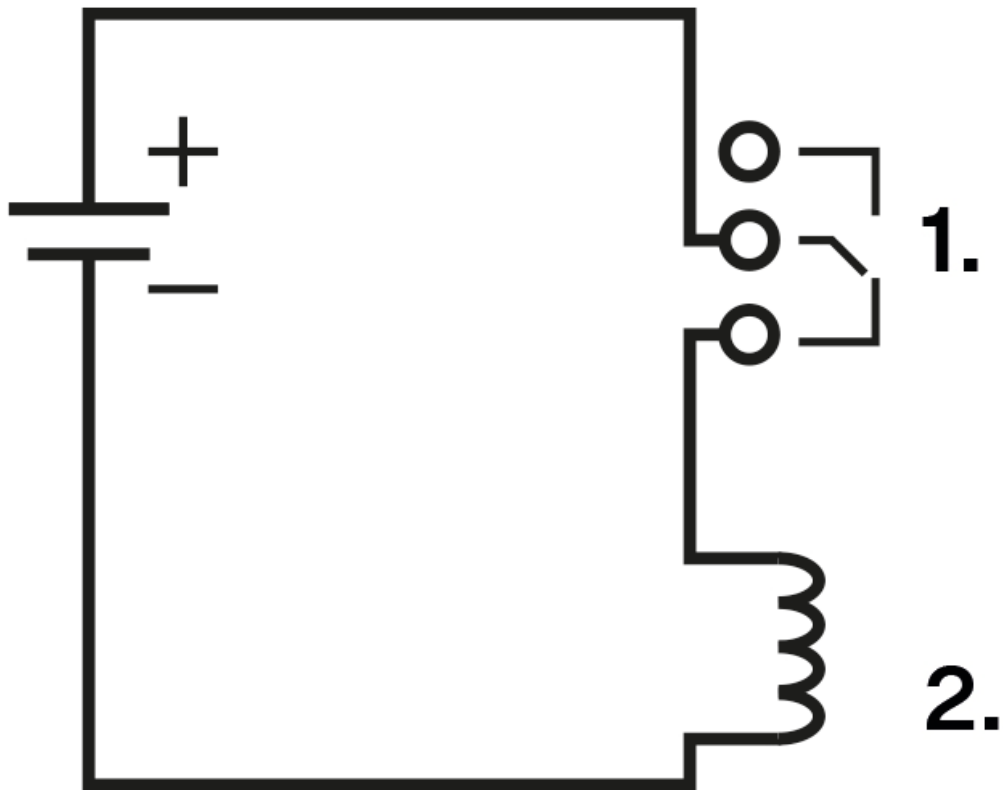

**Connection of IN1 inputs (or IN2/3)**

It is possible to connect an external button, e.g. a departure button or door open sensor, to the IN1 or IN2/3 terminals of device2N Access Unit 2.0.

The following wiring diagrams apply both to IN1 and IN2 and IN3 .

**Wiring diagram of IN1 terminals in active mode**

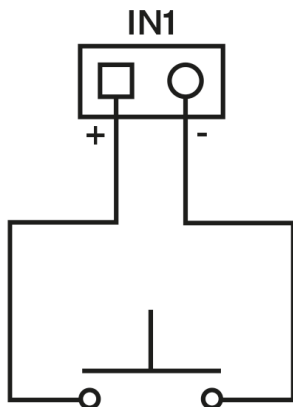

**Wiring diagram of IN1 terminals in passive mode**

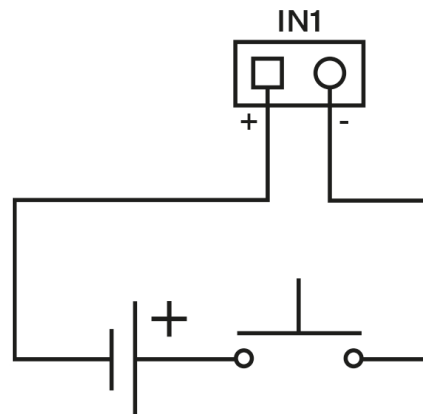

## Board Versions

This subsection includes diagrams showing the main PCB connectors for different board versions.

### Access Unit 2.0 – Motherboard version 599v6

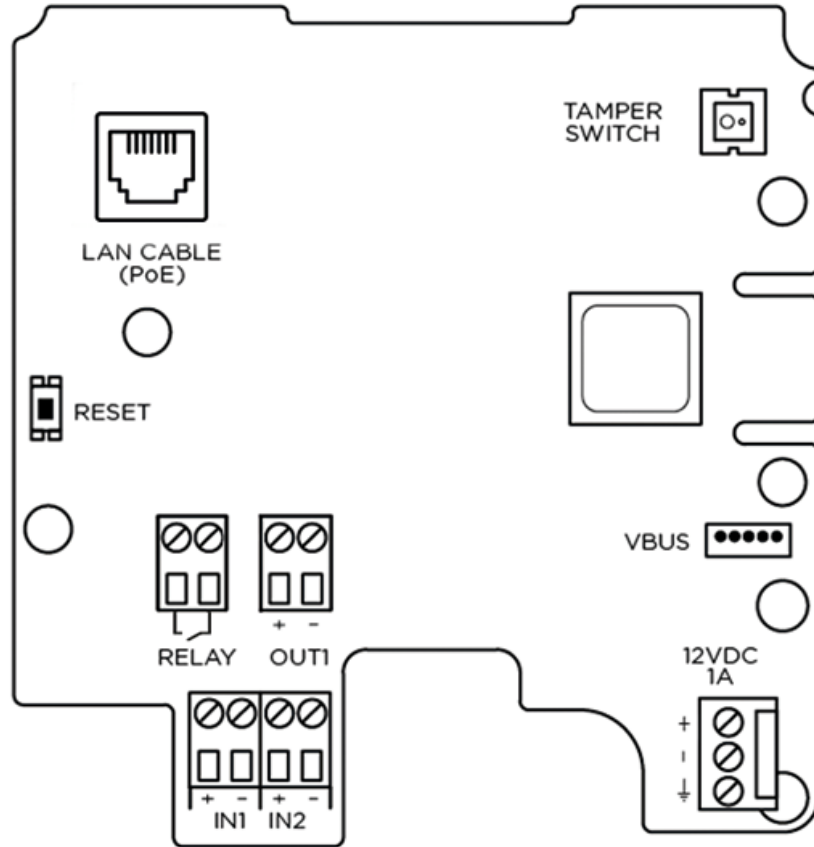

The RESET button is located to the left below the LAN connector.



### WARNING

- Do not remove the small metal plate under the power connector. The metal plate is responsible for the metal frame grounding, its removal may compromise the electrostatic discharge resistance.
- We recommend that a grounding cable of the cross-section of 1,5 mm<sup>2</sup> is used.



### CAUTION

The order of the power connector terminals has been changed on and a grounding metal plate has been added to the motherboard version 599v6.

### Access Unit 2.0 – Motherboards 599v3 and 599v4

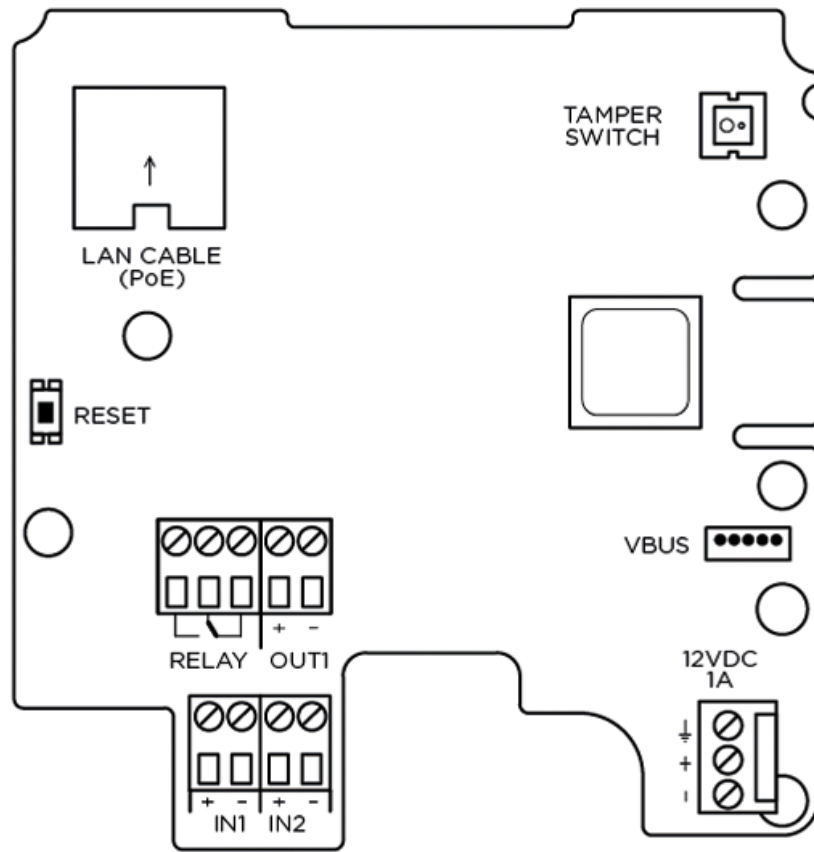

The RESET button is located to the left below the LAN connector.

### Access Unit – Motherboard 586v2

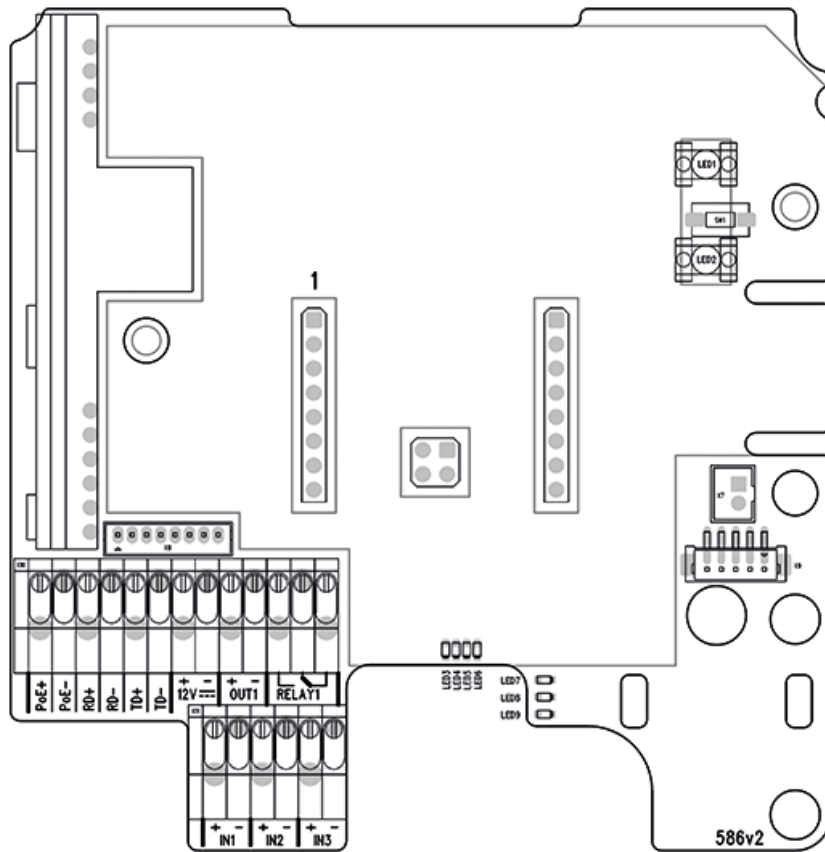

The RESET button is located in the right-hand upper part of the unit.

## Access Unit – Motherboard 586v4

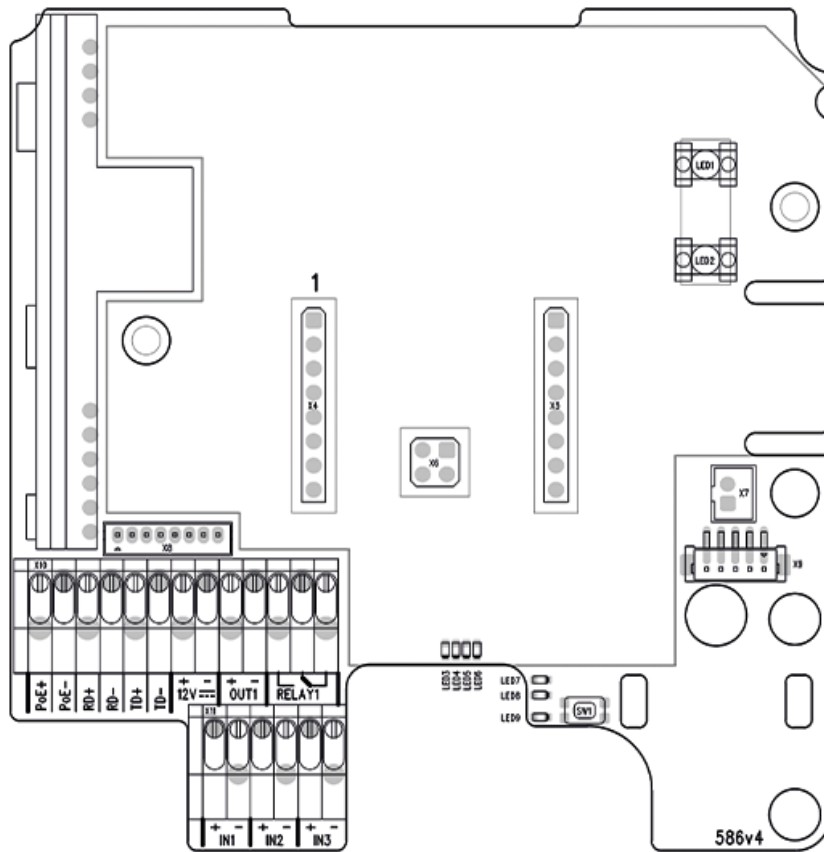

The RESET button is located in the middle of the bottom.

### Available Switches

The following switches are available on the above-mentioned main unit boards:

Switch	Description
RELAY 1	<p>Motherboard 599v6 and higher:</p> <ul style="list-style-type: none"> <li>Passive switch: NO contact, up to 30 V / 1 A AC/DC. Used for connection of non-critical devices only (lights, e.g.).</li> </ul> <hr/> <p>Motherboards 599v3 and 599v4 + 586v2 and higher:</p> <ul style="list-style-type: none"> <li>Passive switch: NO/NC contact, up to 30 V / 1 A AC/DC. Used for connection of non-critical devices only (lights, e.g.).</li> </ul> <hr/>
OUTPUT 1	<p>Active switch output: 8 to 12 V DC according to power supply (PoE: 10 V; adapter: supply voltage minus 2 V), up to 600 mA.</p> <hr/>

Switch	Description
Tamper Switch	<p>The tamper switch is a sensor integrated directly into the main unit of the device.</p> <p>The tamper switch detects the opening of the device cover, which is evaluated by the software as a logical switch closure. In this way, the switch indicates any potential physical tampering with the device.</p> <p>When you activate a tamper switch, you can disable all the other switches or set up Automation to trigger a follow-up action, such as sending an email, creating an HTTP request or activating a silent alarm.</p>

**DANGER**

If a coil containing device is connected, e.g. relays/electromagnetic locks, it is necessary to protect the device output against voltage peak while switching off the induction load. For this way of protection we recommend a 1 A / 1000 V diode (e.g., 1N4007, 1N5407, 1N5408) connected antiparallel to the device.

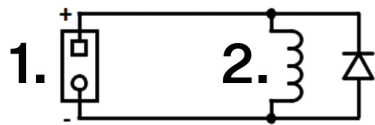

1. Terminals
2. Coil. e.g. relay or electromagnetic lock

**WARNING**

The 12V output is used for lock connection. If the device is installed in a location where there is a danger of unauthorized access (building front, e.g.), we strongly recommend the use of the 2N Security Relay (9159010, 01386-001) to ensure the maximum installation security.

**LAN Connection**

**2N Access Unit 2.0** is connected to the LAN by inserting a SFTP cable (Cat-5e or higher) terminated with an RJ-45 plug into the marked LAN connector on the device. As the device is equipped with the Auto-MDIX function, you can use either the straight or crossed cable version.

This device must be deployed within a network infrastructure that provides adequate protection against Denial-of-Service (DoS) attacks and similar network-based threats. The device does not include built-in protection against high-volume or malicious traffic and relies on the surrounding network environment—such as fire-

walls, intrusion prevention systems, or rate limiting—for defense. Failure to implement appropriate network security measures may lead to service degradation or unavailability. The equipment's user documentation shall contain a [description of all exposed network interfaces and all services exposed via network interfaces](#), which are delivered as part of the factory default state.



### WARNING

On the first launch, the device must only be connected to a secure and trusted network that is fully under control of the user or administrator.

If the device is first configured on an insecure or public network, there is a risk of an unauthorized person taking control of the device.

This device cannot be connected directly to telecom lines (or public wireless networks) of any telecom service providers (i.e. mobile providers, landline providers or Internet providers). A router has to be used for the device Internet connection.

Recommendation: Use a secure network or private Wi-Fi protected with a strong password.



### CAUTION

- We recommend the use of a LAN [surge protection](#) (p. 94).
- We recommend the use of a shielded SFTP Ethernet cable.
- In **2N Access Unit 2.0** version 586v2, there may be network problems if a connection cable longer than 30 m is used. In that case we recommend that you:
  - insert another network element (switch) in the route to shorten the jump,
  - feed the device from an external 12 V power supply,
  - Change PoE supply from the phantom version (typically TP-LINK) into supply by free pairs – Phihong injector (91378100).
  - change the Ethernet rate to Half Duplex – 10 Mbps.

## Overvoltage Protection

The 2N device cables have to be protected against atmospheric overvoltage caused by external causes (lightning, e.g.). A surge can damage a device installed outside/inside the building if the wires are unprotected.

Therefore, we recommend that additional overvoltage protectors (OVP) be installed on the outer walls or roof for all the wires leading outside the building. Keep the following instructions while installing overvoltage protectors:

- Make sure that the overvoltage protector is installed as close as possible to the device installed outside the building.
- Make sure that the overvoltage protector is installed as close as possible to the device installed on an external part of the building.
- Make sure that the overvoltage protector is installed as close as possible to the point where the cabling leaves the building.

### Examples of Overvoltage Protection Installation

Overvoltage protection installation diagram for a device installed on the building facade and cables outside the building

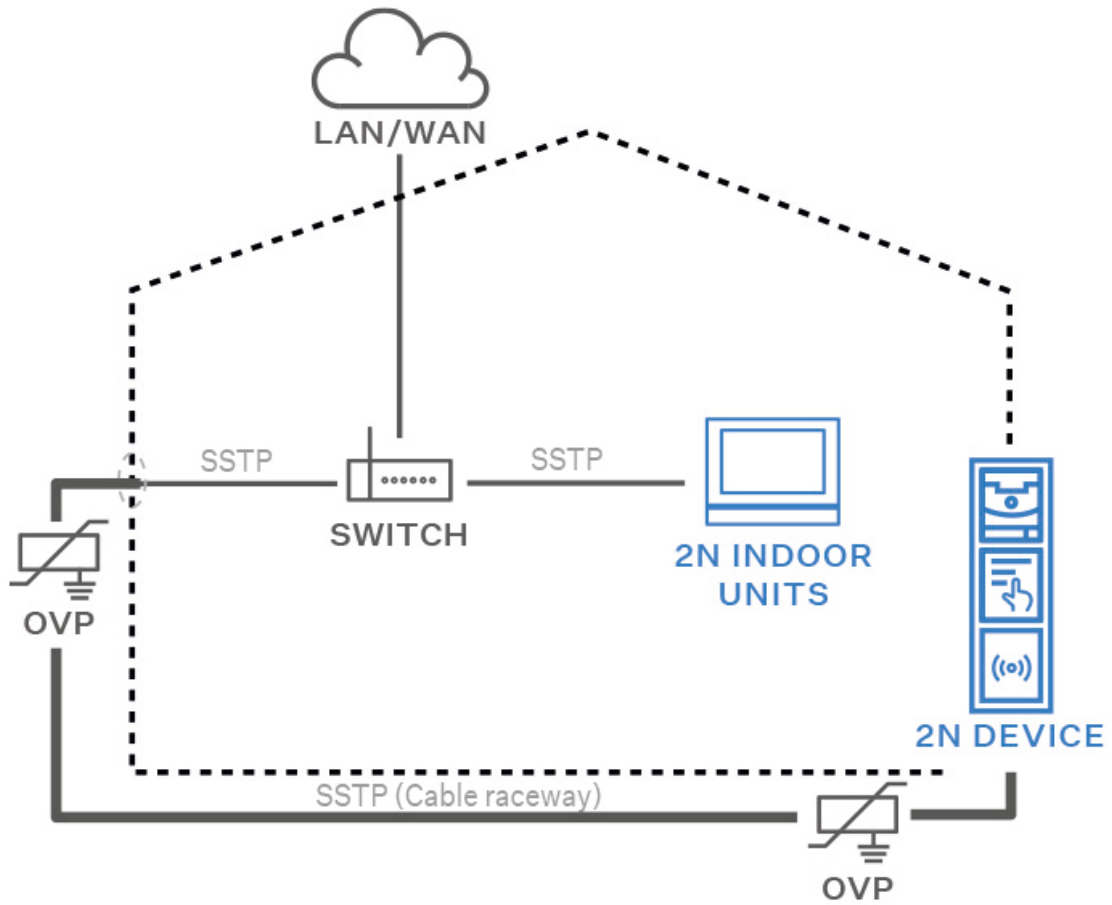

**Overvoltage protection installation diagram for a device installed on the building facade and cables inside the building**

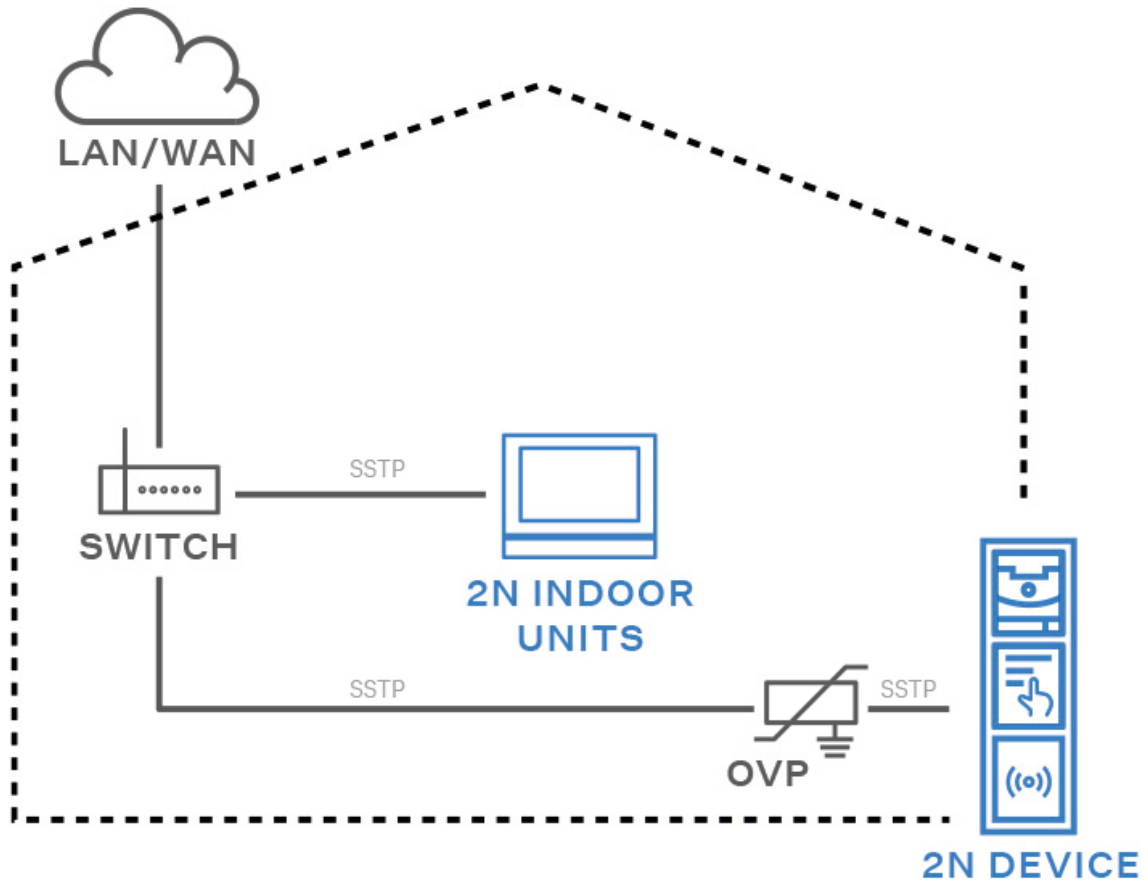

## Overvoltage protection installation diagram for a device and cables installed outside the building

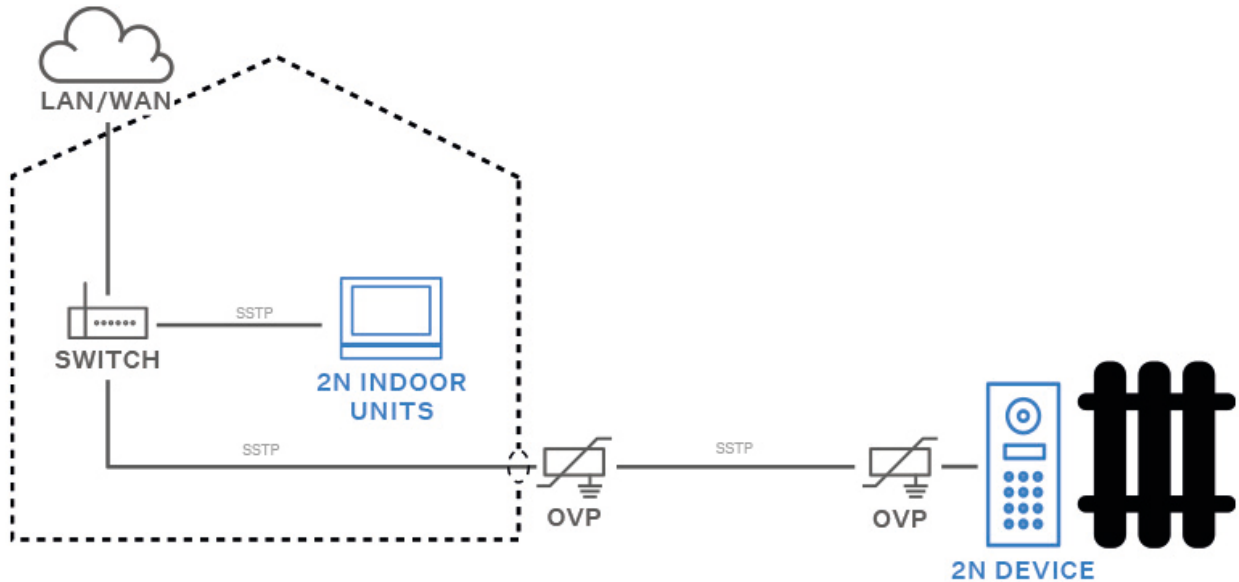

## Installation Completion

Check the connection of all the wires and the RJ-45 plug insertion in the board connector.



### WARNING

- Make sure that all the terminals of the unused connectors are properly tightened to avoid vibrations caused by sound.
- Make sure that all the holes are filled with some waterproof material – the top part, around the cables and the screws.

## Frame Attachment

Check the frame sealing before fitting the frame.

Screw the flush mounting frame in the upper and bottom parts.

Hang the surface mounting frame on the hook in the upper part and then screw it tight in the bottom part.

## Most Frequent Installation Errors

Always mount the metal bolts and level the bases on an even surface **before** tightening the screws.



**WARNING**

Make sure that the bases are levelled properly to avoid water leakage and electronic damage.



See the side view in the drawing above for the right/wrong connection of the bases. Pay particular attention to the base connection detail. You may have a situation especially when the instructions are neglected and the screws are tightened first.

# Main and Extending Modules



## CAUTION

In case the firmware versions of the module to be connected and the main unit are incompatible, the module will not be detected. Therefore, update the device firmware after connecting the modules. Update firmware via the web configuration interface in System > Maintenance.



## TIP

To accelerate access card reading, we recommend that the used card types are only selected in the module settings.



## NOTE

**2N Access Unit 2.0** also supports the **2N IP Verso** extending modules.

**2N Access Unit 2.0** can be interconnected with the following modules:

- [\[cs\] Čtečka RFID karet 125 kHz \(p. 102\)](#)
- [13.56 MHz NFC RFID card reader \(p. 103\)](#)
- [Secured 13.56 MHz, NFC RFID card reader \(p. 103\)](#)
- [125 kHz, 13.56 MHz, NFC Bluetooth & RFID card reader \(p. 104\)](#)
- [125 kHz, secured 13.56 MHz, NFC Bluetooth & RFID card reader \(p. 104\)](#)
- [125kHz, 13.56MHz, NFC touch keypad & RFID card reader \(p. 105\)](#)
- [125kHz, secured 13.56MHz, NFC touch keypad & RFID card reader \(p. 105\)](#)
- [125 kHz, 13.56 MHz, NFC touch keypad & Bluetooth & RFID card reader \(p. 106\)](#)
- [125 kHz, secured 13.56 MHz, NFC touch keypad & Bluetooth & RFID card reader \(p. 107\)](#)
- [Touch keypad \(p. 107\)](#)
- [Biometric fingerprint reader \(p. 108\)](#)
- [Touch display \(p. 108\)](#)
- [Keypad \(p. 109\)](#)
- [I/O module \(p. 109\)](#)
- [Wiegand module \(p. 111\)](#)
- [Security Relay \(p. 115\)](#)
- [OSDP module \(p. 117\)](#)
- [Infopanel \(p. 121\)](#)
- [Blind panel module](#)

## Module Interconnection

All the modules that can be connected to the device are interconnected via a bus. The bus starts on the main unit and goes over all the modules. The order of the modules on the bus is irrelevant. And it is also irrelevant which bus connector is used as the input and which is used as the output on the module.

The modules include a 220 mm long bus interconnecting cable.

The Wiegand, OSDP and I/O modules include an 80 mm long bus cable. These modules can be hidden inside one of the modules described below (Infopanel, Keypad, RFID card reader, Bluetooth) or can be freely placed behind the device (in a mounting box, e.g.). The Tamper Switch, which is not on the bus, is interconnected with one of these modules.

It is possible to order separate bus cables of the length of 1 m, 3 m or 5 m (9155050/9155054/9155055, 01267-001/01268-001/01269-001 respectively), which are intended for remote module installations. Typically, they help install an RFID card reader on the opposite side of the wall on which the device communicator is installed. This cable may only be used once on the bus. The total length of all the bus cables used in these extended installations may not exceed 7 m.

## Module Power Supply

All the modules connected to the device, except for the Tamper Switch, are powered from the bus. The available bus power output depends on the power supply type.

The main unit with motherboard allows an external power supply to be used for increasing the available power output for the modules connected.

Power Supply	Specification	Available power output
External supply	12 V $\pm$ 15 % / 1 A	12 W
PoE	802.3af (Class 0 – 12.95 W)	12 W

## Sample Calculations

The count of modules on the bus is limited by the available power supply output. The maximum count of the modules on the bus is 30.

Main unit with motherboard	Maximum consumption [W]
At relax	1.2
OUT1	4.8
<b>Total</b>	<b>6</b>

## Main and Extending Modules

Module	Maximum idle consumption [W]	Full load [W]
Main unit	1.2	6
Infopanel	0.17	0.35
Keypad	0.12	1.54
Touch keypad	0.12	1.54
Fingerprint reader	0.73	1.54
125 kHz RFID card reader	0.52	1.31
13.56 MHz RFID card reader	0.44	0.82
125 kHz, 13.56 MHz, NFC Bluetooth & RFID card reader	1.34	2.74
125kHz, 13.56MHz, NFC touch keypad & RFID card reader	1.38	2.52
I/O module	0.31 (+ 0.13 for relay activation)	0.65
Wiegand module	0.46	0.46

### Specimen configuration consumption computation

Module	Maximum consumption [W]	Maximum consumption [W]
Main unit	1.2	6
13.56 MHz RFID card reader	0.44	0.82
I/O	0.31	0.65

Module	Maximum consumption [W]	Maximum consumption [W]
Tamper Switch	0	0
Wiegand	0.46	0.46
<b>Total</b>	<b>2.41</b>	<b>7.93</b>

It is obvious from the specimen configuration that all the modules have sufficient outputs when an external power supply is used. When a PoE supply is used, the power output is insufficient for all the modules, which results in automatic decrease in the backlight level, active output current supply, volume level and LED intensity.

Some modules need a specific power output for their specific activities: the I/O module, e.g., requires 0.13 W for relay activation (not included in the minimum consumption).

## Module Specifications



### CAUTION

**2N Access Unit 2.0** supports connection of just one Bluetooth module. If connected, multiple Bluetooth modules may result in a undesired behavior.



### TIP

To accelerate access card reading, we recommend that the used card types are only selected in the module settings.

## 125 kHz RFID Card Reader Module

The 125 kHz RFID card reader module (91550941, 02140-001) is used for reading RFID card IDs in the 125 kHz bandwidth.

To accelerate access card reading, we recommend that the used card types are only selected in the module settings.

## Features

- The module contains two bus connectors for the **2N Access Unit 2.0** bus.
- These two connectors are fully interchangeable and can be used either as inputs from the main unit or outputs to other modules.
- If this module is the last one on the bus, one of the connectors remains unconnected.
- The module package includes a 220 mm long interconnecting cable.

Supported RFID cards 125 kHz:

- EM4x02
- 

### **13.56 MHz, NFC RFID Card Reader Module**

The 13.56 MHz RFID card reader (91550942, 02139-001) is used for reading RFID card IDs in the 13.56 kHz bandwidth.

To accelerate access card reading, we recommend that the used card types are only selected in the module settings.

### **Features**

- The module contains two bus connectors for the **2N Access Unit 2.0** bus.
- These two connectors are fully interchangeable and can be used either as inputs from the main unit or outputs to other modules.
- If this module is the last one on the bus, one of the connectors remains unconnected.
- The module package includes a 220 mm long interconnecting cable.

Supported RFID cards 13.56 MHz:

- **ISO14443A** (MIFARE Classic, MIFARE Plus, MIFARE Mini, MIFARE Ultralight, MIFARE DESFire CSN only)
- **ISO14443B** (Calypso)
- **PicoPass** (HID iClass CSN, Picopass)
- **FeliCa** (Standard, Lite)
- **ST SR** (SR, SRI, SRIX)
- **My2N**
- **2N PICard**

### **Secured 13.56 MHz NFC RFID Card Reader Module**

The 13.56 MHz RFID card reader (91550942-S/9155086, 02141-001/01712-001) is used for reading secured RFID card IDs in the 13.56 MHz bandwidth.

### **Features**

- The module contains two bus connectors for the **2N Access Unit 2.0** bus.
- These two connectors are fully interchangeable and can be used either as inputs from the main unit or outputs to other modules.
- If this module is the last one on the bus, one of the connectors remains unconnected.
- The module package includes a 220 mm long interconnecting cable.

Supported RFID cards 13.56 MHz:

- **ISO14443A** (MIFARE Classic, MIFARE Plus, MIFARE Mini, MIFARE Ultralight, MIFARE DESFire CSN only)
- **ISO14443B** (Calypso)
- **PicoPass** (HID iClass CSN, Picopass)
- **FeliCa** (Standard, Lite)
- **ST SR** (SR, SRI, SRIX)
- **HID PAC** (HID SEOS, HID iClass SE, iClass SR, HID MIFARE DESFire with SIO, HID MIFARE Classic with SIO)
- **My2N**
- **2N PICard**

## Bluetooth & 125 kHz, 13.56 MHz, NFC RFID Card Reader Module

The Bluetooth & 125 kHz and 13.56 MHz card reader module (91550945, 02778-001) is used for access control using a smartphone/tablet with **My2N** or an access card, for making user calls and/or controlling other functions.

To accelerate access card reading, we recommend that the used card types are only selected in the module settings.

### Features

- NFC – for **2N My2N** for Android only, a licensed function.
- The module contains two bus connectors for the **2N Access Unit 2.0** bus.
- These two connectors are fully interchangeable and can be used either as inputs from the main unit or outputs to other modules.
- If this module is the last one on the bus, one of the connectors remains unconnected.
- The module package includes a 220 mm long interconnecting cable.

Supported RFID cards 125 kHz:

- EM4x02
- 

Supported RFID cards 13.56 MHz:

- **ISO14443A** (MIFARE Classic, MIFARE Plus, MIFARE Mini, MIFARE Ultralight, MIFARE DESFire CSN only)
- **ISO14443B** (Calypso)
- **PicoPass** (HID iClass CSN, Picopass)
- **FeliCa** (Standard, Lite)
- **ST SR** (SR, SRI, SRIX)
- **My2N**
- **2N PICard**

## Bluetooth & 125 kHz, secured 13.56 MHz, NFC RFID Card Reader Module

The Bluetooth & 125 kHz and secured 13.56 MHz card reader module (91550945-S, 02444-001) is used for access control using a smartphone/tablet with **2N My2N** or an access card, for making user calls and/or controlling other functions.

To accelerate access card reading, we recommend that the used card types are only selected in the module settings.

### Features

- NFC – for **2N My2N** for Android only, a licensed function.
- The module contains two bus connectors for the **2N Access Unit 2.0** bus.
- These two connectors are fully interchangeable and can be used either as inputs from the main unit or outputs to other modules.
- If this module is the last one on the bus, one of the connectors remains unconnected.
- The module package includes a 220 mm long interconnecting cable.

Supported RFID cards 125 kHz:

- EM4x02
- 

Supported RFID cards 13.56 MHz:

- **ISO14443A** (MIFARE Classic, MIFARE Plus, MIFARE Mini, MIFARE Ultralight, MIFARE DESFire CSN only)
- **ISO14443B** (Calypso)
- **PicoPass** (HID iClass CSN, Picopass)
- **FeliCa** (Standard, Lite)
- **ST SR** (SR, SRI, SRIX)
- **HID PAC** (HID SEOS, HID iClass SE, iClass SR, HID MIFARE DESFire with SIO, HID MIFARE Classic with SIO)
- **My2N**
- **2N PICard**

### **Touch Keypad & 125 kHz, 13.56 MHz, NFC RFID Card Reader Module**

The touch keypad & 125 kHz and 13.56 MHz card reader module (91550946, 02779-001) is used for code/card access control, making user calls and/or controlling other functions. The touch keypad surface is very sensitive yet weatherproof at the same time.

To accelerate access card reading, we recommend that the used card types are only selected in the module settings.

#### **Features**

- NFC – for **2N My2N** for Android only, a licensed function.
- The module contains two bus connectors for the **2N Access Unit 2.0** bus.
- These two connectors are fully interchangeable and can be used either as inputs from the main unit or outputs to other modules.
- If this module is the last one on the bus, one of the connectors remains unconnected.
- The module package includes a 220 mm long interconnecting cable.

Supported RFID cards 125 kHz:

- EM4x02
- 

Supported RFID cards 13.56 MHz:

- **ISO14443A** (MIFARE Classic, MIFARE Plus, MIFARE Mini, MIFARE Ultralight, MIFARE DESFire CSN only)
- **ISO14443B** (Calypso)
- **PicoPass** (HID iClass CSN, Picopass)
- **FeliCa** (Standard, Lite)
- **ST SR** (SR, SRI, SRIX)
- **My2N**
- **2N PICard**

### **Touch Keypad & 125 kHz, secured 13.56 MHz, NFC RFID Card Reader Module**

The touch keypad with a combined 125 kHz and secured 13.56 MHz card reader (91550946-S, 02443-001) is used for code/card access control, making user calls and/or controlling other functions. The touch keypad surface is very sensitive yet weatherproof at the same time.

To accelerate access card reading, we recommend that the used card types are only selected in the module settings.

#### **Features**

- NFC – for **2N My2N** for Android only, a licensed function.
- The module contains two bus connectors for the **2N Access Unit 2.0** bus.

- These two connectors are fully interchangeable and can be used either as inputs from the main unit or outputs to other modules.
- If this module is the last one on the bus, one of the connectors remains unconnected.
- The module package includes a 220 mm long interconnecting cable.

Supported RFID cards 125 kHz:

- EM4x02
- 

Supported RFID cards 13.56 MHz:

- **ISO14443A** (MIFARE Classic, MIFARE Plus, MIFARE Mini, MIFARE Ultralight, MIFARE DESFire CSN only)
- **ISO14443B** (Calypso)
- **PicoPass** (HID iClass CSN, Picopass)
- **FeliCa** (Standard, Lite)
- **ST SR** (SR, SRI, SRIX)
- **HID PAC** (HID SEOS, HID iClass SE, iClass SR, HID MIFARE DESFire with SIO, HID MIFARE Classic with SIO)
- **My2N**
- **2N PICard**

### Touch Keypad & Bluetooth & 125 kHz, 13.56 MHz, NFC RFID Card Reader Module

The touch keypad with Bluetooth and a combined 125 kHz and 13.56 MHz card reader (91550947, 02781-001) is used for access control using a smartphone/tablet with **2N My2N** or code/access card, for making user calls and/or controlling other functions. The touch keypad surface is very sensitive yet weather-proof at the same time.

To accelerate access card reading, we recommend that the used card types are only selected in the module settings.

### Features

- NFC – for **2N My2N** for Android only, a licensed function.
- The module contains two bus connectors for the **2N Access Unit 2.0** bus.
- These two connectors are fully interchangeable and can be used either as inputs from the main unit or outputs to other modules.
- If this module is the last one on the bus, one of the connectors remains unconnected.
- The module package includes a 220 mm long interconnecting cable.

Supported RFID cards 125 kHz:

- EM4x02
- 

Supported RFID cards 13.56 MHz:

- **ISO14443A** (MIFARE Classic, MIFARE Plus, MIFARE Mini, MIFARE Ultralight, MIFARE DESFire CSN only)
- **ISO14443B** (Calypso)
- **PicoPass** (HID iClass CSN, Picopass)
- **FeliCa** (Standard, Lite)
- **ST SR** (SR, SRI, SRIX)
- **My2N**
- **2N PICard**

## Touch Keypad & Bluetooth & 125 kHz, secured 13.56 MHz, NFC RFID Card Reader Module

The touch 02781-001 keypad & Bluetooth & 125 kHz and secured 13.56 MHz card reader module (91550947-S, 02782-001) is used for access control using a smartphone/tablet with **2N My2N** or code/access card, for making user calls and/or controlling other functions. The touch keypad surface is very sensitive yet weatherproof at the same time.

To accelerate access card reading, we recommend that the used card types are only selected in the module settings.

### Features

- NFC – for **2N My2N** for Android only, a licensed function.
- The module contains two bus connectors for the **2N Access Unit 2.0** bus.
- These two connectors are fully interchangeable and can be used either as inputs from the main unit or outputs to other modules.
- If this module is the last one on the bus, one of the connectors remains unconnected.
- The module package includes a 220 mm long interconnecting cable.

Supported RFID cards 125 kHz:

- EM4x02
- 

Supported RFID cards 13.56 MHz:

- **ISO14443A** (MIFARE Classic, MIFARE Plus, MIFARE Mini, MIFARE Ultralight, MIFARE DESFire CSN only)
- **ISO14443B** (Calypso)
- **PicoPass** (HID iClass CSN, Picopass)
- **FeliCa** (Standard, Lite)
- **ST SR** (SR, SRI, SRIX)
- **HID PAC** (HID SEOS, HID iClass SE, iClass SR, HID MIFARE DESFire with SIO, HID MIFARE Classic with SIO)
- **My2N**
- **2N PICard**



#### CAUTION

Press the “key” button on the card reader (without having entered any numbers) on the touch keypad & Bluetooth & RFID card reader module to start Bluetooth authentication.

## Touch Keypad Module

The Touch Keypad module (9155047, 01277-001) is used for numeric access to the system. Also, it helps you control the lock and other functions via a numeric code. The keypad digits and symbols are backlit.

### Features

- The module contains two bus connectors for the **2N Access Unit 2.0** bus.
- These two connectors are fully interchangeable and can be used either as inputs from the main unit or outputs to other modules.
- If this module is the last one on the bus, one of the connectors remains unconnected.

- The module package includes a 220 mm long interconnecting cable.

## Biometric Fingerprint Reader Module

The Biometric fingerprint reader module (9155045, 01276-001) is used for verification of human fingers for access control and 2N/third party equipment control.



### WARNING

The fingerprint reader may not be installed on places exposed to direct sunlight. If exposed to direct sunlight, the device may report errors.

## Features

- The module contains two bus connectors for the **2N Access Unit 2.0** bus.
- These two connectors are fully interchangeable and can be used either as inputs from the main unit or outputs to other modules.
- If this module is the last one on the bus, one of the connectors remains unconnected.
- The module package includes a 220 mm long interconnecting cable.

Important module properties:

- FBI PIV and Mobile ID certification – FAP20
- durable glass touch surface
- rejection of spoof fingerprints
- operating temperature range: -20 to 55 °C
- 0–90 % relative humidity, noncondensing



### CAUTION

- A higher moisture may deteriorate the finger papillary line scanning. You are advised to dry your finger and the reader scanning surface for successful authentication.
- Fingerprint scanning may be more difficult for seniors whose finger papillary lines are not so distinctive (skin elasticity drops with age and a higher scanning pressure may lead to fingerprint blurring).

## Touch Display Module

The Touch display (9155036, 01275-001) can be used as:

- Infopanel Module – displays the user defined image sequence
- Keypad module – virtual touch keypad



### CAUTION

Display is not supported in Access Unit 1.0 FW version 2.27 and higher.

## Specification

Resolution	320 px x 214 px H x V
Slideshow resolution	214 px x 214 px
Contrast ratio	400
Brightness	350 cd/m <sup>2</sup>
Viewing angle	80 ° from any direction
Weight	280 g
Operating temperature	-20 to +60°C
Resistance level	IK07

## Connectors and Installation

Connection Options:

- The module contains two bus connectors for the **2N Access Unit 2.0** bus.
- These two connectors are fully interchangeable and can be used either as inputs from the main unit or outputs to other modules.
- If this module is the last one on the bus, one of the connectors remains unconnected.
- The module package includes a 220 mm long interconnecting cable.

## Keypad Module

The Keypad module (Part No. 9155031/9155031B, 01253-001/01254-001) is used for numeric access to the system.

## Features

- The module contains two bus connectors for the **2N Access Unit 2.0** bus.
- These two connectors are fully interchangeable and can be used either as inputs from the main unit or outputs to other modules.
- If this module is the last one on the bus, one of the connectors remains unconnected.
- The module package includes a 220 mm long interconnecting cable.

## I/O Module

The I/O module (9155034, 01257-001) is used for extending the inputs and outputs. The module is designed for integration of sensors or other devices. The module is installed below another module, i.e. cannot be installed directly into **2N Access Unit 2.0** (must be located outside).

## Features

- The module contains two bus connectors for the **2N Access Unit 2.0** bus.

- These two connectors are fully interchangeable and can be used either as inputs from the main unit or outputs to other modules.
- If this module is the last one on the bus, one of the connectors remains unconnected.
- The module package includes a 80 mm long interconnecting cable.
- The inputs / outputs are addressed as follows: <module\_name>.<input/output\_name>, e.g. "module5.relay1". Configure the module name in the Module Name parameter in **Hardware > Extending modules**.

## Connectors and Installation

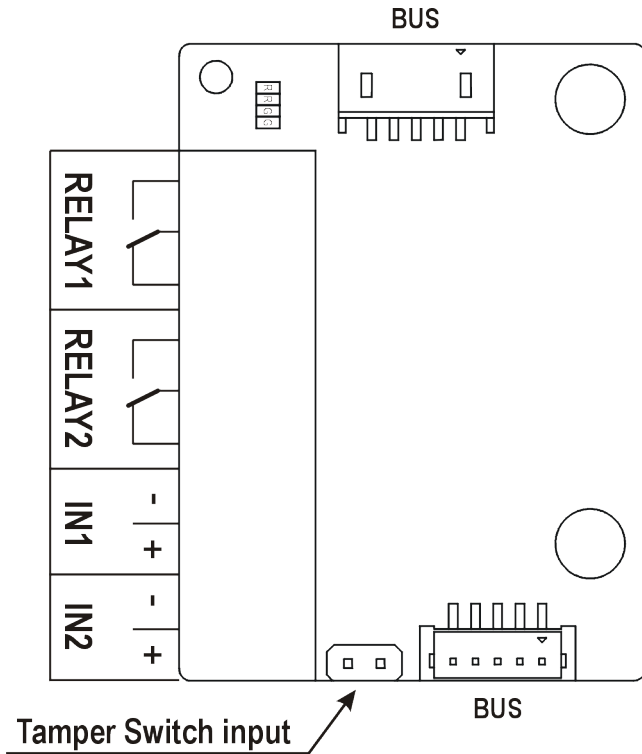

RELAY1/2      RELAY1/2 terminals with accessible 30 V / 1 A AC/DC NO/NC contact

IN1/2          IN1/2 terminals for input in passive / active mode (-30 V to +30 V DC)

- OFF = open or  $U_{IN} > 1.5 \text{ V}$
- ON = short-circuited or  $U_{IN} < 1.5 \text{ V}$

TAMPER        Tamper Switch (9155038, 01260-001) input



### NOTE

2N Access Unit 2.0 has an integrated tamper switch.

The module is installed under another module, i.e. needs no separate position.

1.

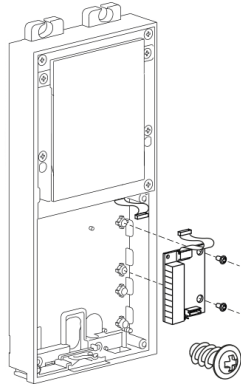

2.

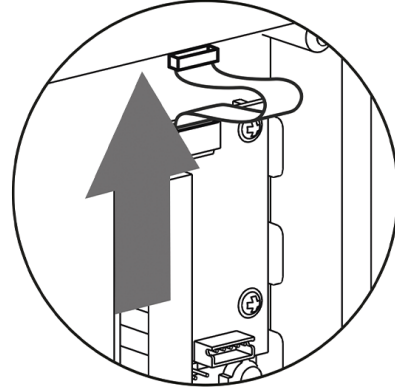

## Wiegand Module

The Wiegand module (9155037, 01259-001) is used for connecting an external Wiegand device (RFID card reader, fingerprint/biometric data scanner) and/or connecting **2N Access Unit 2.0** to an external security exchange.

## Features

- The module contains two bus connectors for the **2N Access Unit 2.0** bus.
- These two connectors are fully interchangeable and can be used either as inputs from the main unit or outputs to other modules.
- If this module is the last one on the bus, one of the connectors remains unconnected.
- The module package includes a 80 mm long interconnecting cable.
- Configure the module name in the Module Name parameter in **Hardware > Extending modules**.
  - LED IN is addressed as follows: <module\_name>.<input1>, e.g. "module2.input1".
  - The Tamper input is addressed as follows: <module\_name>.<tamper>, e.g. "module2.tamper".
  - LED OUT (negated) is addressed as follows: <module\_name>.<output1>, e.g. "module2.output1".

## Specification

### Technical Parameters of Wiegand Input

Current	5 mA
.....	
Input resistance	680 Ω
.....	
Pulse length	50 μs
.....	
Inter-pulse interval	approx. 2 ms

## Connectors and Installation

All the inputs and outputs are galvanically isolated from the device with the insulation strength of 500 V DC. It is necessary to feed +U<sub>IN</sub> on Wiegand W0<sub>OUT</sub> from the Control Panel.

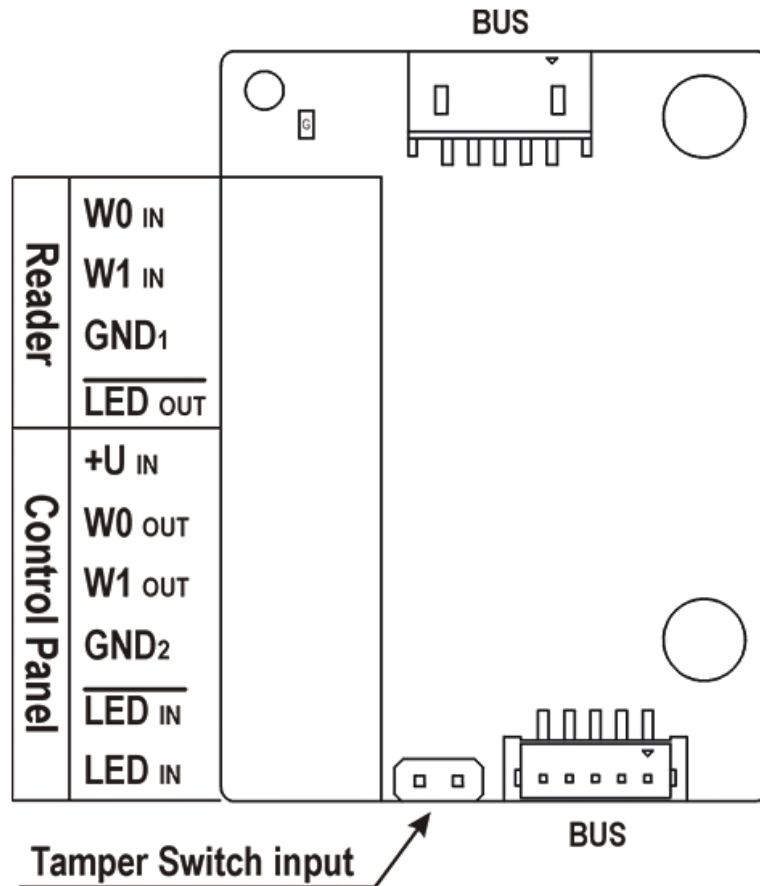

Reader helps connect an external Wiegand-supporting reader. The reader sends the device card ID.

The Control Panel is used for connection to the security PBX / access system to which the device sends the card ID information.

The module contains two BUS connectors for device bus connection. These two connectors are fully interchangeable and can be used either as inputs from the main unit or outputs to other modules.

Reader	W0 <sub>IN</sub> , W1 <sub>IN</sub> , GND <sub>1</sub>	Isolated 2-wire WIEGAND IN
	LED <sub>OUT</sub>	Isolated open LED OUT switched against GND <sub>1</sub> (up to 24 V / 50 mA)

## Main and Extending Modules

Control Panel	+U <sub>IN</sub>	+U <sub>IN</sub> (5 to 15 V DC) for WIEGAND OUT power supply
	W0 <sub>OUT</sub> , W1 <sub>OUT</sub> , GND <sub>2</sub>	Isolated 2-wire WIEGAND OUT
	LED <sub>IN</sub> (nega- ted)	Isolated input for open LED IN, input activated by GND <sub>2</sub> connec- tion
	LED <sub>IN</sub>	Isolated input for open LED IN, input activated after +U connec- tion
	G	+U <sub>IN</sub> WIEGAND OUT active supply LED indicator
	TAMPER	Tamper Switch (9155038, 01260-001) input

The module is installed under another module, i.e. needs no separate position.

1.

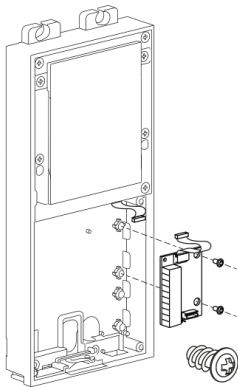

2.

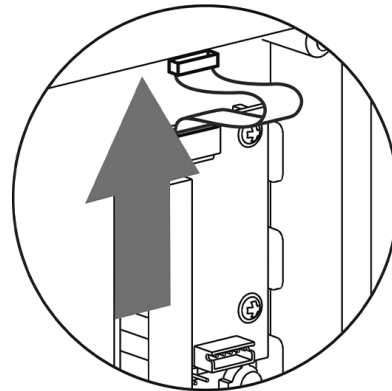

**Recommended Wiegand bus wiring diagram, 2N device as a receiver.**

1. **2N Access Unit 2.0**
2. External RFID Card Reader

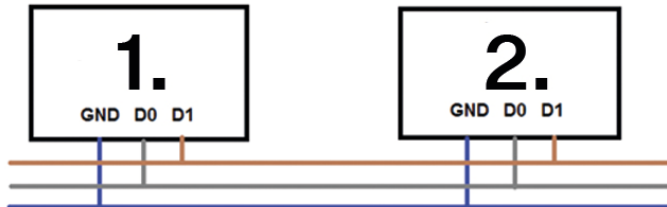

**Recommended Wiegand bus wiring diagram, 2N device as a transmitter.**

1. External RFID Card Reader
2. **2N Access Unit 2.0**

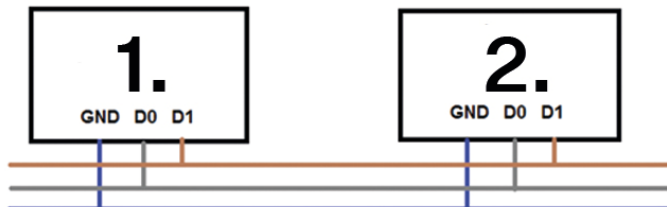

## Recommended reader & OC output wiring diagram

1. **2N Access Unit 2.0**
2. External RFID Card Reader
3. 5 V power supply

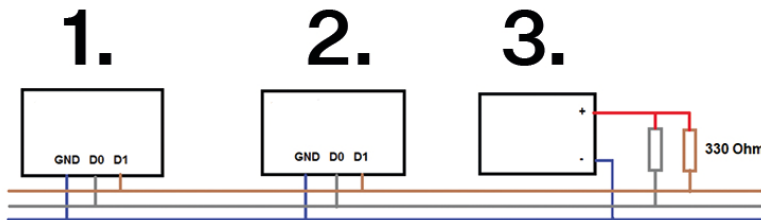

## Security Relay

The Security Relay (9159010, 01386-001) is used for enhancing security between **2N Access Unit 2.0** and the connected electric lock. The Security Relay significantly enhances security of the connected electric lock by preventing unlocking due to device tampering.



### TIP

FAQ: [2N Security Relay – description of the device and use with the 2N intercoms](#)

## Specification

Passive switch      NO/NC contact, up to 30 V / 1 A AC/DC

Switched out-  
put

- Where the Security Relay is fed from the device, 8 to 12 V DC is available on the output depending on the power supply, 400 mA DC.
  - PoE: 10 V
  - adapter: source voltage of minus 2 V
- Where the Security Relay is fed from an external power supply, 12 V / 700 mA DC is available on the output.

Dimensions      66.5 × 32.5 × 20.5 mm

Weight      24 g

## Connectors and Installation

The Security Relay is installed between the device (outside the secured area) and the electric lock (inside the secured area). The Security Relay includes a relay that can only be activated if a valid access card/code is detected on the unit.

The Security Relay is installed on a two-wire cable between the device and the electric lock inside the area to be secured (typically behind the door). The Security Relay is powered and controlled via this two-wire cable and can thus be added to an existing installation. Thanks to its compact dimensions, the device can be installed into a standard mounting box.

The Security Relay is designed with holes for surface anchoring. It is recommended that a screw of the diameter of 3 mm with a lens head of the diameter of 6 mm is used. Using a countersunk head may cause irreversible damage to the plastic cover!

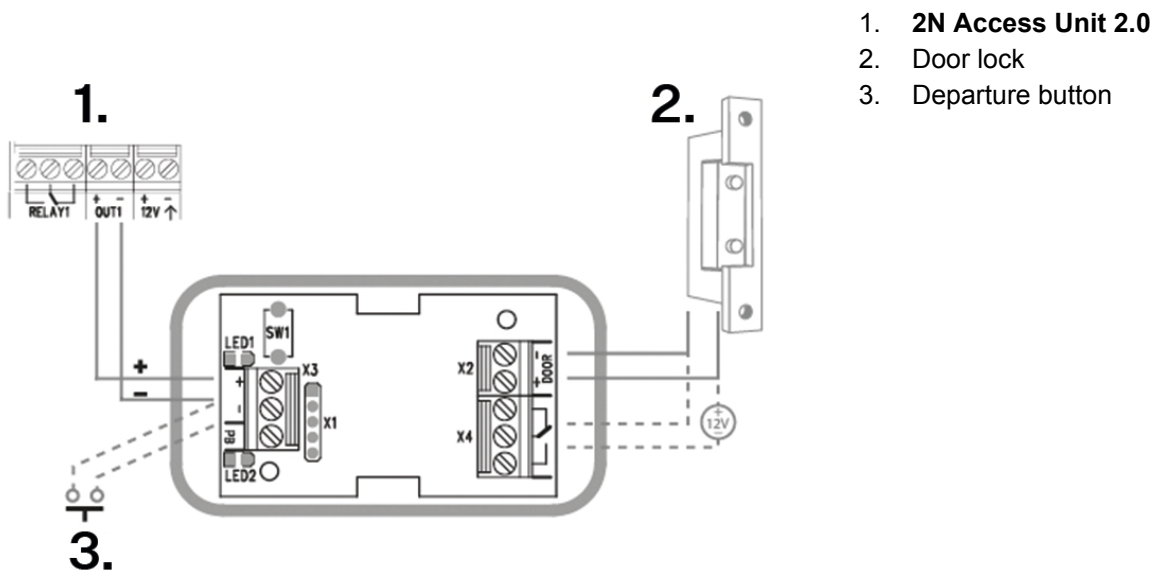

Connect the Security Relay to the access unit as follows:

- To the Active output

Connect the electric lock to the Security Relay as follows:

- to the switched output
- to the passive output in series with the external power supply

The Security Relay also supports the Departure button connected to the 'PB' and '- 2N IP intercom' terminals. Once the Departure button is pressed, the output is activated for 5 seconds.

<https://www.youtube.com/embed/ardukvQzw5A>

## Status Signaling

Green LED	Red LED	State
flashing	off	Operational mode

Green LED	Red LED	State
on	off	Activated output
flashing	flashing	Programming mode – waiting for initialization
on	flashing	Error – wrong code

## Configuration

1. Connect the Security Relay to the properly set Security output of the device. Refer to the Configuration Manual for details. Make sure that one LED at least is on or flashing.
2. Press and hold the Relay RESET button for 5 seconds to switch the device in the programming mode (red and green LEDs flashing).
3. Activate the output switch using the keypad, telephone, etc. The first code sent from the device will be stored in the memory and considered valid. After code initialization, the Security Relay will pass into the operational mode (green LED flashing).



### CAUTION

Having reset the factory defaults on a device with firmware 2.18 or higher, remember to reprogram Security Relay using the instructions above.

## OSDP Module

The OSDP module (91550371, 02577-001) of **2N Access Unit 2.0** provides OSDP communication between a connected OSDP device (control panel, door controller) and the device. The OSDP module provides secure sending of such access data as the access card ID or PIN code.

## Features

- The module contains two bus connectors for the **2N Access Unit 2.0** bus.
- These two connectors are fully interchangeable and can be used either as inputs from the main unit or outputs to other modules.
- If this module is the last one on the bus, one of the connectors remains unconnected.
- The module package includes a 80 mm long interconnecting cable.

The module also includes:

- Isolated OSDP bus
- Power and pairing mode signaling LED
- Tamper Switch (9155038, 01260-001) input

## Connectors and Installation

All the inputs and outputs are galvanically isolated from **2N Access Unit 2.0** with the insulation strength of 1500 V DC.

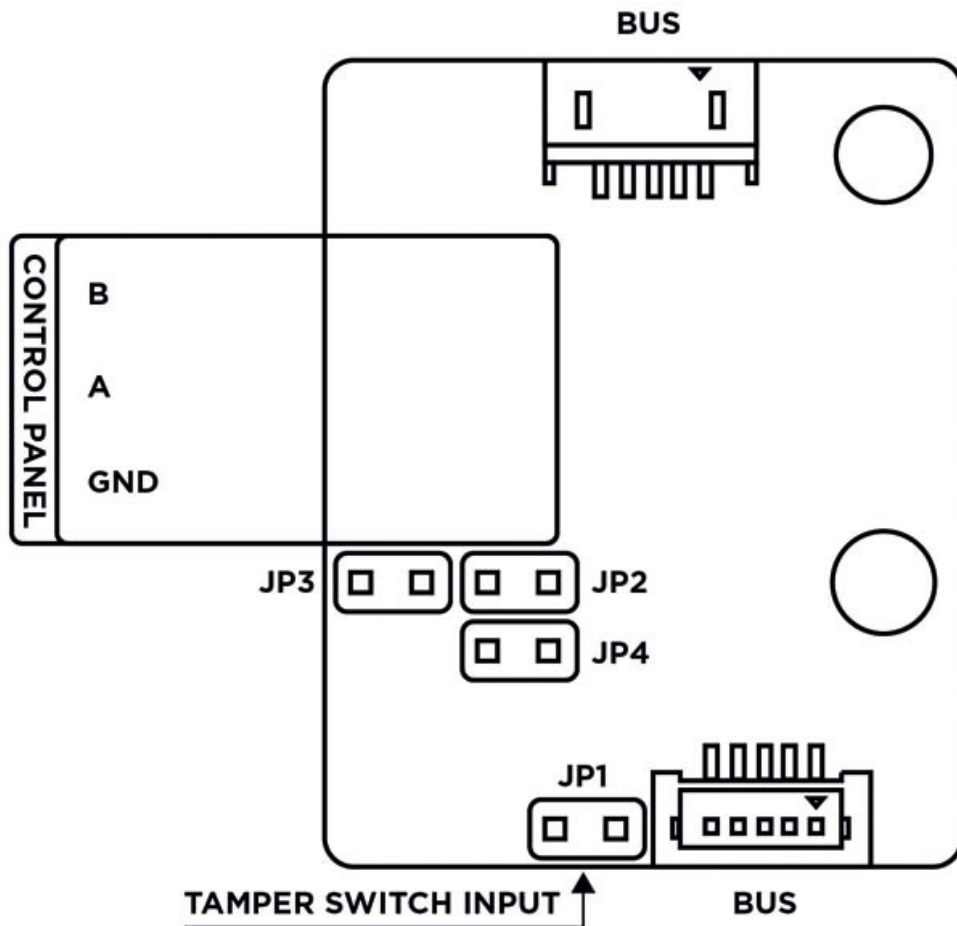

BUS VBUS connectors for the bus connection

Control Panel:

A, B

GND

JP1/2/3/4 Jumpers 1/2/3/4

TAMPER Tamper Switch (9155038, 01260-001) input



**NOTE**

2N Access Unit 2.0 has an integrated tamper switch.

The module is installed under another module, i.e. needs no separate position.

1. Having connected the OSDP module to **2N Access Unit 2.0** via the VBUS, connect the OSDP device to the module. The OSDP module uses the RS-485 bus for the interface.

2. Connect the OSDP device as instructed (A to B or B to A) keeping the correct order to avoid malfunction.



**CAUTION**

- Mounting jumpers JP2 and JP3 results in a connection of strong pull-up/pull-down resistors (560 ohms) to the RS-485 bus. These jumpers must be mounted/unmounted together, i.e. one jumper cannot be mounted alone. Strong pull-up and pull-down resistors can be connected only and exclusively to one arbitrary device on the OSDP bus.
- Mounting JP4 results in a connection of the terminating 120 ohm resistor between wires A and B of the OSDP bus. The terminating resistors may be connected exclusively on the first and last modules on the OSDP bus. We recommend the connection of these resistors on the first and last modules.

1.

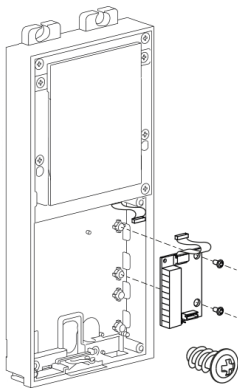

2.

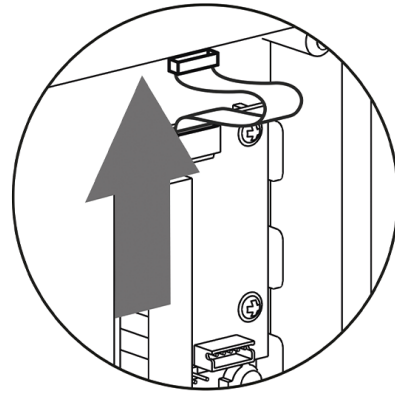

## Connection Recommendations

### Wiring diagram for two-wire connection

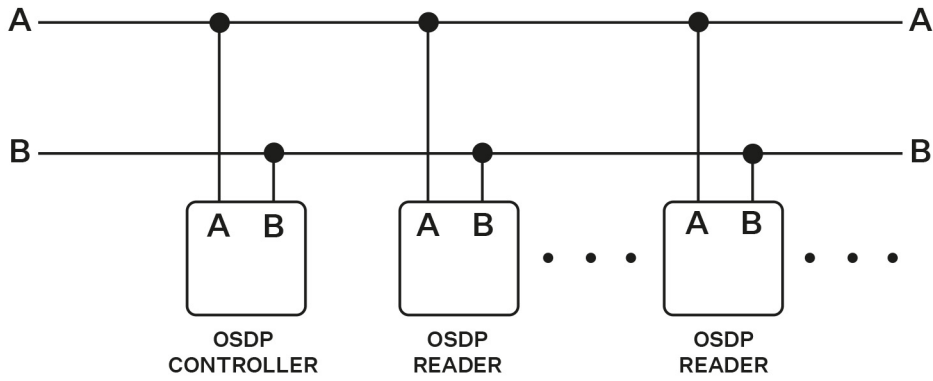

### Wiring diagram for three-wire connection

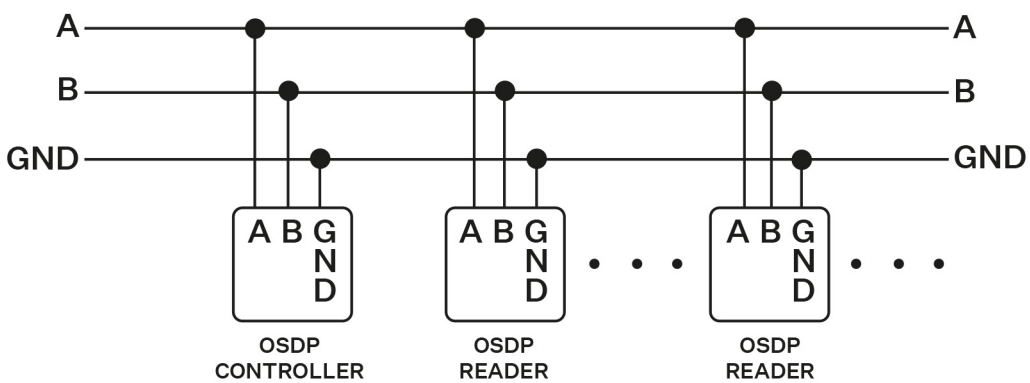

## Configuration

Having logged in to the device web interface, use the **Hardware > Extending modules** menu to set the following:

1. Name the module for user identification (optional).
2. Choose a group for access data resending, making sure that the settings are identical with those of the access readers from which the data are to be resent (card ID, PIN).
3. The setting of the codes to be transmitted is optional.
4. Enter the OSDP address between 0 and 126 to set the OSDP module address on the OSDP line.
5. Set the communication rate in accordance with the requirements of the device to be connected.
6. Enter your own encryption key into **2N Access Unit 2.0** and the opponent's device to ensure encrypted communication.
7. Enable forced encryption just for encrypted communication.

Any unencrypted communication from the OSDP device will be rejected if forced encryption is enabled.

If the OSDP device enables remote encryption key setting on a peripheral, you can use the installation mode. Once the encryption key is received, the common mode is automatically switched on. The installation mode is signaled by a LED fast flashing on the OSDP module.

## Infopanel Module

The Infopanel module (9155030, 0159-7891) is used for inserting and backlighting printed information. It helps place a company logo or opening hours, e.g., to the device. The Infopanel is backlit, the backlight is software controlled. Refer to [2N.com](http://2N.com) for the printing template.

## Features

- The module contains two bus connectors for the **2N Access Unit 2.0** bus.
- These two connectors are fully interchangeable and can be used either as inputs from the main unit or outputs to other modules.
- If this module is the last one on the bus, one of the connectors remains unconnected.
- The module package includes a 220 mm long interconnecting cable.

## Specification

Nametag dimensions (W x H)

69.2 x 86.7 mm (tolerance: +0; -0.5 mm)

# Brief Guidelines

## IP Address Retrieval

To retrieve the device IP address, take the following steps:

- Use the freely accessible 2N IP Utility.
- Use hardware (RESET button).

### IP Address Retrieval Using 2N IP Utility

The 2N IP Utility application helps find the 2N device IP address in the LAN. Download 2N IP Utility from the [2N.com](https://www.2n.com) website. Make sure that Microsoft .NET Framework 4.7.2 is installed for successful app installation.

1. Run the 2N IP Utility installer.
2. The Installation Wizard will help you with the installation.
3. Having installed 2N IP Utility, start the application using the Microsoft Windows Start menu. Once started, the application begins to automatically search the LAN for all the 2N and AXIS devices which have been DHCP/statically assigned IP addresses. These devices are then shown in a table.

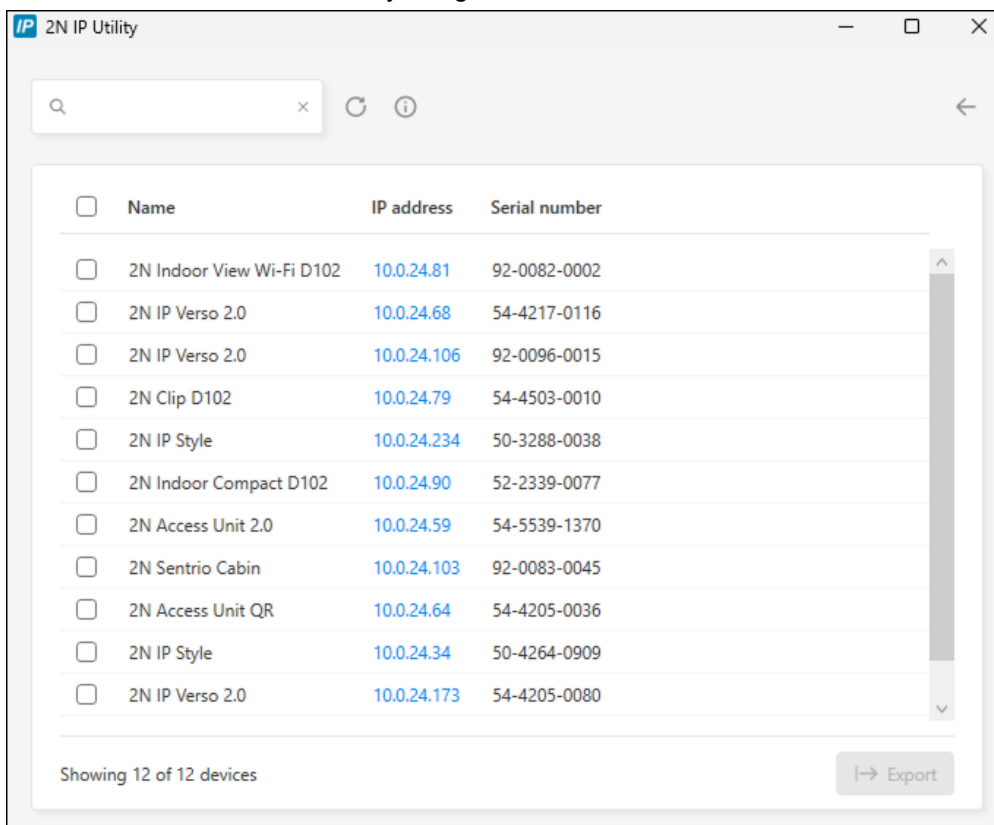

4. Select the device to be configured and left-click it. This opens the right-hand part of the web configuration interface window.



**TIP**

- Access to the web configuration interface is also possible via the **Open in external browser** button, which opens the interface in a separate browser window.
- Click a device in the list to display detailed information. Click the **IP settings** button to change the IP address by entering the required static IP address or activating DHCP.
- The application also allows you to export selected devices into a CSV file. First select a device by ticking the boxes in the list, then use the **Export** button that appears at the bottom of the window. The exported file shall include the names, IP addresses and serial numbers of the selected devices.

The default login data are:

Username: **Admin**

Password: **2n**

It is necessary to change the password immediately upon the first login.



**TIP**

It is recommended that a password is used that is difficult to break. It is not recommended that names, places or things, especially those closely related to the user, are used in the password.

For increased password security, it is recommended that:

- the random password generator is used,
- the password length is 12 characters at least,
- various characters from different character sets are combined (small/capital letters, digits, special characters, etc.).

### IP Address Retrieval Using the RESET button

Follow the instructions below to retrieve the current IP address:

1. Press the button RESET and keep it pressed.
  - a. Wait until the red and green LEDs go on simultaneously on the device and the acoustic signal can be heard 🗣️ (approx. 15–35 s).
2. Release the RESET button.
3. The device announces the current IP address via the speaker automatically.



**NOTE**

The delay after pressing RESET till the first light and sound signaling is set to 15–35 s depending on the device model used.

## Access to web device configuration

Configure **2N Access Unit 2.0** via a web configuration interface, which is accessible from a web browser.



You need to know the IP address or domain name of the device for access to the interface. Make sure that the device is connected to the local IP network and powered.

The web configuration interface can also be accessed from the connected My2N portal or the 2N Access Commander configuration tool.

### Web Configuration Interface Login

1. Start your Internet browser.
2. Enter the device IP address or domain name (refer to Subs.[Finding devices in the network](#)).
3. If no certificate has been generated for the IP address, a security certificate invalidity notification may appear. In that case, confirm that you want to go to the web configuration interface.
4. The login screen is now displayed.
5. Enter the login data.  
The default login data are:
  - Username: **Admin**
  - Password: **2n**
6. After the first login, change the password.

### Access from 2N Access Commander

1. Log in to the Access Commander interface.
2. Go to the  Devices page.
3. For the selected device, press .

### Password Change

You must change the default password to get full access to the web configuration interface features. You cannot configure the device without changing the default password.

**TIP**

It is recommended that a password is used that is difficult to break. It is not recommended that names, places or things, especially those closely related to the user, are used in the password.

For increased password security, it is recommended that:

- the random password generator is used,
- the password length is 12 characters at least,
- various characters from different character sets are combined (small/capital letters, digits, special characters, etc.).

## Recommended browsers

The web configuration interface is optimized for the Chromium-based web browsers (Google Chrome, Microsoft Edge or Opera, e.g.). With other browsers, there may be slight differences in the interface function and appearance.

## Firmware Update

New firmware versions are available on the update server. If the web configuration interface does not provide access to the public Internet, it is possible to upload the firmware file manually to the device.



### NOTE

Firmware updates are not automatic. To ensure system integrity and eliminate unintentional failures, all updates must be manually confirmed or initiated by the user. Please check the release notes of the new version and verify compatibility with your existing infrastructure before performing any updates.

## Getting Firmware from Update Server

1. Go to **System > Maintenance > Firmware**.
2. Click **Check for Updates**.
3. If an update is available, its release notes are loaded. To start the upgrade, click **Upgrade** in the window header.
4. Once the firmware is uploaded successfully, the device is restarted automatically. After the restart, the device becomes fully operational with a new firmware version. The FW upgrade does not affect configuration.

## Uploading New Firmware from Storage

1. Go to **System > Maintenance > Firmware**.
2. Click **Upload Firmware**.
3. In the open dialog box, select a file from your own storage.
4. Click **Upload** to confirm the file upload.  
The device checks the firmware file and prevents you from uploading an incorrect or corrupt file.
5. Once the firmware is uploaded successfully, the device is restarted automatically. After the restart, the device becomes fully operational with a new firmware version. The FW upgrade does not affect configuration.



### NOTE

The functions, reliability and security of the device depend on the firmware installed. Regular firmware upgrades to the latest version are included in the product terms of use. Errors that may be caused by the use of an outdated firmware version cannot be the subject of a claim. The current firmware implements customer experience and requirements in the field of personal data security.

## Device Restart

To restart the device choose one of the following options:

- using power disconnection and reconnection
- via the web configuration interface.
- using the RESET button,

The device restart does not result in any change in the configuration settings.

## Restart Using Web Configuration Interface

1. Open the web configuration interface.
2. Go to **System > Maintenance**.
3. Press **Restart Device** in the page header.

## Restart Using RESET Button

Press the button shortly (< 1 s) to restart the system without changing configuration.

**2N Access Unit 2.0** is equipped with a RESET button. Its position is different in different [board versions \(p. 88\)](#):

- It is located to the left below the LAN connector in the 599v6, 599v3 and 599v4 versions.
- It is located between the LEDs (LED1, LED2) in the right-hand upper part of the unit in 586v2.
- It is in the middle of the bottom in 586v4.

## Factory Default Reset

The factory settings can be restored

- via the web configuration interface.
- Use hardware (RESET button).











### CAUTION

In case the factory default values are reset on the device with a firmware version 2.18 or higher, it is necessary to reprogram the 2N Security Relay using the instructions given in [Security Relay \(p. 115\)](#).

## Factory Default Reset via Web Configuration Interface

Soft reset the device factory default values in **System > Maintenance** using Default Reset.

## Factory Default Reset with RESET Button

1. Press the button RESET and keep it pressed.
  - a. Wait until the red and green LEDs go on simultaneously on the device and the acoustic signal can be heard  (approx. 15–35 s).
  - b. Wait until the red LED goes off and an acoustic signal can be heard  (approx. for another 3 s).
  - c. Wait until the green LED goes off and the red LED goes on again and an acoustic signal can be heard    (approx. for another 3 s).
  - d. Wait until the red LED goes off and the acoustic signal can be heard     (approx. for another 3 s).

2. Release the RESET button.

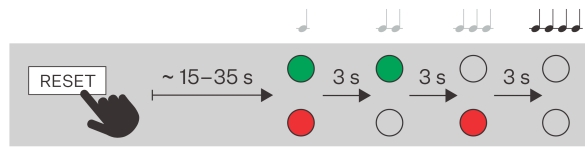

## Configuration via Hardware

Where software configuration is unavailable, the basic settings can be made using the RESET button.

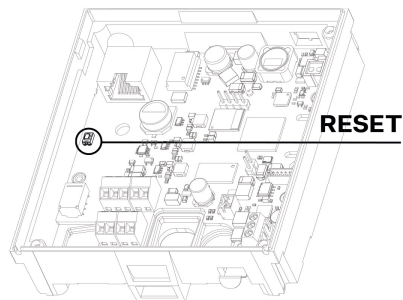

The location of the RESET button on **2N Access Unit 2.0** may vary depending on the board version (see [Board Versions \(p. 88\)](#)).

- It is located to the left below the LAN connector in the 599v6, 599v3 and 599v4 versions.
- It is located between the LEDs (LED1, LED2) in the right-hand upper part of the unit in 586v2.
- It is in the middle of the bottom in 586v4.

The RESET button helps you retrieve the device IP address, switch the dynamic/static IP address mode or reset the factory values.

### Device Restart

Press the button shortly (< 1 s) to restart the system without changing configuration.

# Device Control

**2N Access Unit 2.0** is a modular access system that meets all individual user configuration needs. Unlike other access systems available on the market, **2N Access Unit 2.0** is not a single-module system with a fixed functionality, but represents a user friendly modular system, allowing the user to assemble required modules and accessories on a plug&play basis. This approach allows for individual system configurations and also leaves space for additional functionality if necessary.

The device works as an authorization intermediary, which authenticates the user access rights and, if the user access is valid, activates the switch. The door lock, lifts etc. can be controlled by the switch.

The device control depends on the product version:

- using RFID cards and chips – by tapping a card/chip on the device,
- using the **2N My2N** application – by pressing the device touchscreen in the vicinity of a mobile device with **2N My2N** logged in,
- using NFC,
- using biometric data (fingerprint),
- by entering a numeric access code via a keypad application

## Colour Signalling

Devices with a display or LED pictograms display different statuses in color.

### Status Signaling

Color	State	Description
Red	Active Access Blocking	Occurs if access is not allowed (it is not possible to activate the door switch) or occurs again after a specified period of time after the door switch is deactivated.
	Switch Locking	Applies to a switch that is configured as a door switch.
	Secured Status	Display of this status is only allowed on the device main unit if signaling is available.
Blue	Entering Access Code	Occurs when the user is entering the code and signals the possibility to confirm the code.
Green	Access Enable	Occurs when the access lock is deactivated and signals door opening or switch activation.

## Maintenance - Cleaning

**2N Access Unit 2.0** contains no environmentally harmful components. Dispose of the device in accordance with the applicable legal regulations.

If used frequently, the device surface gets dirty. Use a piece of soft cloth moistened with clean water to clean the device. Use appropriate cleaning agents suitable for glasses, optical devices, screens, etc. We recommend that IT cleaning wipes are used.



### CAUTION

Use the product for the purposes it was designed and manufactured for, in compliance herewith. The manufacturer reserves the right to modify the product in order to improve its qualities.

If used frequently, the device surface gets dirty. Use a piece of soft cloth moistened with clean water to clean the device. Use appropriate cleaning agents suitable for glasses, optical devices, screens, etc. We recommend that IT cleaning wipes are used.

- Alcohol-based cleaners may not be applied.
- Do not use aggressive detergents (such as abrasives or strong disinfectants).
- Prevent water from getting inside the device.
- Clean the device in dry weather in order to make waste water evaporate quickly.



### TIP

To disinfect the surface of the device against bacteria and viruses (Anti-Covid) and maintain the hygienic conditions of critical surfaces and touch points, we recommend that you use the Zoono – Microbe Shield Surface Sanitiser spray.

# Troubleshooting

Refer to <https://www.2n.com/faqs> for the most frequently solved problems.

# Technical Parameters

## Power supply types

PoE IEEE PoE 802.3af (Class 0, max. 12,95 W) (Class 0, max. 12.95 W)

External supply 12 V  $\pm$ 15 % / 1 A DC



### WARNING

**2N Access Unit 2.0** with HW version 599v4 or lower cannot be fed from an external power supply and PoE at the same time. A combined supply might result in a device damage.

## Audio

Speaker 0.8 W / 8  $\Omega$

## Interface

LAN 10/100BASE-TX with Auto-MDIX, RJ-45

Recommended cabling Cat-5e or higher

Supported protocols DHCP opt. 66, SMTP, 802.1x, TFTP, HTTP, HTTPS, Syslog

Passive switch (relay) NO/NC contact, up to 30 V / 1 A AC/DC

Active switch output 8 to 12 V DC according to power supply, up to 600 mA

- PoE: 10 V
- adapter: source voltage  $-2$  V

**Tamper Switch**  
(part of the 2N Access Unit 2.0 main unit)

Inputs	Can be used in passive or active mode (-30 V to +30 V DC) <ul style="list-style-type: none"> <li>• OFF = open or <math>U_{IN} &gt; 1.5 \text{ V}</math></li> <li>• ON = short-circuited or <math>U_{IN} &lt; 1.5 \text{ V}</math></li> </ul>
--------	--

**Bluetooth**

Bluetooth	in compliance with BLE (Bluetooth Low Energy)
RX sensitivity	up to -93 dBm
Support of mobile applications	Android 10.0 and higher, iOS 17.0 and higher

**I/O module, Wiegand module**

Dimensions	43 x 31.5 x 1.5 mm
------------	--------------------

**Mechanical Parameters**

Cover	Robust zinc casting with surface finish (minor surface shade nuances are acceptable).
-------	---

Body material	<p>Versions:</p> <ul style="list-style-type: none"> <li>• Light version - Nickel:                 <ul style="list-style-type: none"> <li>• Material - Zamak 410 - Zn95Al4Cu1</li> <li>• Surface treatment - Zn/Cu20/Ni25b max. 80 <math>\mu\text{m}</math></li> </ul> </li> </ul>
---------------	---

Surface installation dimensions	One-module	107 x 130 x 28 mm
	Two-module	107 x 234 x 28 mm

## Technical Parameters

### Mechanical Parameters

Flush installation dimensions	Frame – one-module	130 x 153 x 5 mm
	Frame – two-module	130 x 257 x 5 mm
	Box (minimum wall hole) – one-module	108 x 131 x 45 mm
	Box (minimum wall hole) – two-module	108 x 238 x 45 mm
Weight (depending on configuration)	Max. net	2 kg
	Max. gross	0.5 kg
Operating temperature		-40 °C to 60 °C
Relative humidity		10 to 95 % (non-condensing)
Storing temperature		-40 °C to 70 °C
Recommended altitude		up to 2000 m
Protection class		IP54
Resistance level		

## General Instructions and Cautions

Please read this User Manual carefully before using the product and follow the instructions and recommendations included therein.

Any use of the product that is in contradiction with the instructions provided herein may result in malfunction, damage or destruction of the product.

The manufacturer shall not be liable and responsible for any damage incurred as a result of a use of the product other than that included herein, namely undue application and disobedience of the recommendations and warnings.

Any use or connection of the product other than those included herein shall be considered undue and the manufacturer shall not be liable for any consequences arisen as a result of such misconduct.

Moreover, the manufacturer shall not be liable for any damage or destruction of the product incurred as a result of misplacement, incompetent installation and/or undue operation and use of the product in contradiction herewith.

The manufacturer assumes no responsibility for any malfunction, damage or destruction of the product caused by incompetent replacement of parts or due to the use of reproduction parts or components.

The manufacturer shall not be liable and responsible for any loss or damage incurred as a result of a natural disaster or any other unfavorable natural condition.

The manufacturer shall not be held liable for any damage of the product arising during the shipping thereof.

The manufacturer shall not make any warrant with regard to data loss or damage.

The manufacturer shall not be liable and responsible for any direct or indirect damage incurred as a result of a use of the product in contradiction herewith or a failure of the product due to a use in contradiction herewith.

All applicable legal regulations concerning the product installation and use as well as provisions of technical standards on electric installations have to be obeyed. The manufacturer shall not be liable and responsible for damage or destruction of the product or damage incurred by the consumer in case the product is used and handled contrary to the said regulations and provisions.

The consumer shall, at its own expense, procure software protection of the product. The manufacturer shall not be held liable for any damage incurred as a result of the use of deficient security software.

The consumer shall, without delay, change the access password for the product after installation. The manufacturer shall not be held liable or responsible for any damage incurred in connection with the use of the original password.

The manufacturer also assumes no responsibility for additional costs incurred by the consumer as a result of making calls to increased tariff lines.

### Directives, Laws and Regulations

**2N Access Unit 2.0** conforms to the following directives and regulations:

#### EU

- 2012/19/EU on waste electrical and electronic equipment

- 2014/53/EU for radio equipment
- 2011/65/EU on the restriction of the use of certain hazardous substances in electrical and electronic equipment

## Industry Canada

This Class B digital apparatus complies with Canadian ICES-003/NMB-003.

## Legislation of Thailand

เครื่องโทรคมนาคมและอุปกรณ์นี้  
มีความสอดคล้องตามมาตรฐานหรือขอ  
กำหนดทางเทคนิคของ กสทช.

  
**nabp.**

เครื่องวิทยุคมนาคมนี้ ได้รับยกเว้น ไม่ต้องได้  
รับใบอนุญาตให้มี ใช้ซึ่งเครื่องวิทยุคมนาคม  
หรือตั้งสถานีวิทยุคมนาคมตามประกาศ กสทช.  
เรื่อง เครื่องวิทยุคมนาคม และสถานีวิทยุ  
คมนาคมที่ได้รับยกเว้นไม่ต้องได้รับใบอนุญาต  
วิทยุคมนาคมตามพระราชบัญญัติวิทยุคมนาคม  
พ.ศ. 2498



**nabp.** โทรคมนาคม  
กำกับดูแลเพื่อประชาชน  
Call Center 1200 (InSW)

## Legislation of Japan

本製品は、特定無線設備の技術基準適合証明を受けています。

この装置は、クラス B 機器です。この装置は、住宅環境で使用この装置は、クラス B 機器です。この装置は、住宅環境で使用することを目的としていますが、この装置がラジオやテレビジョン受信機に近接して使用されると、受信障害を引き起こすことがあります。取扱説明書に従って正しい取り扱いをして下さい。  
VCCI - B

本製品は、シールドネットワークケーブル(STP)を使用して接続してください。また適切に接地してください。

本製品は電気通信事業者（移動通信会社、固定通信会社、インターネットプロバイダ等）の通信回線（公衆無線 LAN を含む）に直接接続することができません。本製品をインターネットに接続する場合は、必ずルータ等を経由し接続してください。

## Electric Waste and Used Battery Pack Handling



Do not place used electric devices and battery packs into municipal waste containers. An undue disposal thereof might impair the environment!

Deliver your expired household electric appliances and battery packs removed from them to dedicated dumpsites or containers or give them back to the dealer or manufacturer for environmental-friendly disposal.

## General Instructions and Cautions

a). The dealer or manufacturer shall take the product back free of charge and without requiring another purchase. Make sure that the devices to be disposed of are complete.

Do not throw battery packs into fire. Battery packs may not be taken into parts or short-circuited either.



2N Access Unit 2.0 – Installation Manual

© 2N Telekomunikace a. s., 2026

**2N.com**